



# DIGITAL VIDEO DISC PLAYER

## DVD905

# *SERVICE Manual*

### DIGITAL VIDEO DISC PLAYER

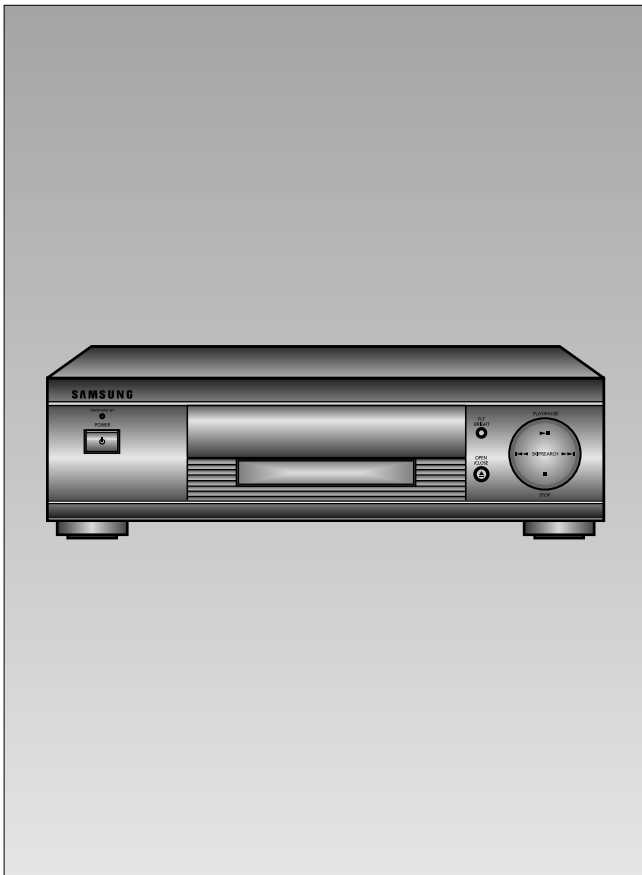

### CONTENTS

1. Precautions
2. Reference Information
3. Product Specifications
4. Disassembly and Reassembly
5. Thoubleshooting
6. Exploded Views and Parts List
7. Electrical Parts List
8. Block Diagram
9. PCB Diagrams
10. Wiring Diagram
11. Schematic Diagrams

# 1. Precautions

1. Be sure that all of the built-in protective devices are replaced. Restore any missing protective shields.
2. When reinstalling the chassis and its assemblies, be sure to restore all protective devices, including : control knobs and compartment covers.
3. Make sure that there are no cabinet openings through which people--particularly children --might insert fingers and contact dangerous voltages. Such openings include the spacing between the picture tube and the cabinet mask, excessively wide cabinet ventilation slots, and improperly fitted back covers.

If the measured resistance is less than 1.0 megohm or greater than 5.2 megohms, an abnormality exists that must be corrected before the unit is returned to the customer.

4. Leakage Current Hot Check (See Fig. 1) :  
Warning : Do not use an isolation transformer during this test. Use a leakage current tester or a metering system that complies with American National Standards Institute (ANSI C101.1, *Leakage Current for Appliances*), and Underwriters Laboratories (*UL Publication UL1410, 59.7*).
5. With the unit completely reassembled, plug the AC line cord directly the power outlet. With the unit's AC switch first in the ON position and then OFF, measure the current between a known earth ground (metal water pipe, conduit, etc.) and all exposed metal parts, including : antennas, handle brackets, metal cabinets, screwheads and control shafts. The current measured should not exceed 0.5 milliamp. Reverse the power-plug prongs in the AC outlet and repeat the test.
6. X-ray Limits :  
The picture tube is designed to prohibit X-ray emissions. To ensure continued X-ray protection, replace the picture tube only with one that is the same type as the original.

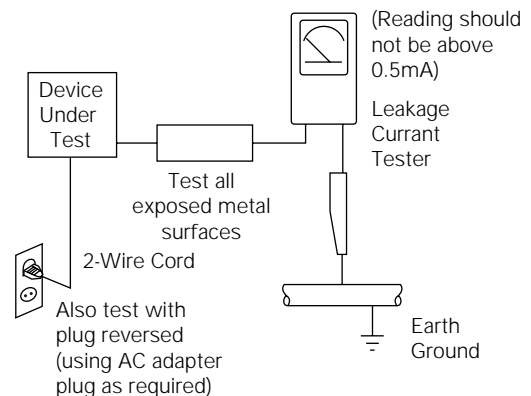



Fig. 1 AC Leakage Test

7. Antenna Cold Check :  
With the unit's AC plug disconnected from the AC source, connect an electrical jumper across the two AC prongs. Connect one lead of the ohmmeter to an AC prong. Connect the other lead to the coaxial connector.
8. High Voltage Limit :  
High voltage must be measured each time servicing is done on the B+, horizontal deflection or high voltage circuits.  
  
Heed the high voltage limits. These include the *X-ray protection Specifications Label*, and the *Product Safety and X-ray Warning Note* on the service data schematic.
9. Some semiconductor ("solid state") devices are easily damaged by static electricity. Such components are called Electrostatically Sensitive Devices (ESDs); examples include integrated circuits and some field-effect transistors. The following techniques will reduce the occurrence of component damage caused by static electricity.
10. Immediately before handling sny semiconductor components or assemblies, drain the electrostatic charge from your body by touching a known earth ground. Alternatively, wear a discharging Wrist-strap device. (Be sure to remove it prior to applying power--this is an electric shock precaution.)

11. High voltage is maintained within specified limits by close-tolerance, safety-related components and adjustments. If the high voltage exceeds the specified limits, check each of the special components.
12. Design Alteration Warning :  
Never alter or add to the mechanical or electrical design of this unit. Example : Do not add auxiliary audio or video connectors. Such alterations might create a safety hazard. Also, any design changes or additions will void the manufacturer's warranty.
13. Hot Chassis Warning :  
Some TV receiver chassis are electrically connected directly to one conductor of the AC power cord. If an isolation transformer is not used, these units may be safely serviced only if the AC power plug is inserted so that the chassis is connected to the ground side of the AC source.  
  
To confirm that the AC power plug is inserted correctly, do the following : Using an AC voltmeter, measure the voltage between the chassis and a known earth ground. If the reading is greater than 1.0V, remove the AC power plug, reverse its polarity and reinsert. Re-measure the voltage between the chassis and ground.
14. Some TV chassis are designed to operate with 85 volts AC between chassis and ground, *regardless of the AC plug polarity*. These units can be safely serviced *only* if an isolation transformer inserted between the receiver and the power source.
15. Never defeat any of the B+ voltage interlocks.  
Do not apply AC power to the unit (or any of its assemblies) unless all solid-state heat sinks are correctly installed.
16. Always connect a test instrument's ground lead to the instrument chassis ground *before* connecting the positive lead; always remove the instrument's ground lead last.
17. Observe the original lead dress, especially near the following areas : Antenna wiring, sharp edges, and especially the AC and high voltage power supplies. Always inspect for pinched, out-of-place, or frayed wiring. Do not change the spacing between components and the printed circuit board. Check the AC power cord for damage. Make sure that leads and components do not touch thermally hot parts.
18. Picture Tube Implosion Warning :  
The picture tube in this receiver employs "integral implosion" protection. To ensure continued implosion protection, make sure that the replacement picture tube is the same as the original.
19. Do not remove, install or handle the picture tube without first putting on shatterproof goggles equipped with side shields. Never handle the picture tube by its neck. Some "in-line" picture tubes are equipped with a permanently attached deflection yoke; do not try to remove such "permanently attached" yokes from the picture tube.
20. Product Safety Notice :  
Some electrical and mechanical parts have special safety-related characteristics which might not be obvious from visual inspection. These safety features and the protection they give might be lost if the replacement component differs from the original—even if the replacement is rated for higher voltage, wattage, etc.  
  
Components that are critical for safety are indicated in the circuit diagram by shading, (  or  ).  
Use replacement components that have the same ratings, especially for flame resistance and dielectric strength specifications. A replacement part that does not have the same safety characteristics as the original might create shock, fire or other hazards.
21. Cautions for handling Pick-up  
Body grounding (hand) : Be sure to wear a wrist strip with one side grounded. (Impedance : Below  $10^{-8} \Omega$  )  
Work table grounding : Put A grounded electric conductor such as copper plate on the work table.  
  
Caution: Do not let clothing touch the product (to prevent possible damage from static electricity).  
  
FPC operation : Handle the FPC carefully because it is easily damaged.

## 1-2 Pick-up disassembly and ressembly

### 1-2-1 Disassembly

- 1) Remove the power cable.
- 2) Switch LD SW3 on deck PCB to 'S' before removing the FPC ( inserted into Main PCB CN1.  
See Fig 1-2.)
- 3) Disassemble the deck.
- 4) Disassemble the deck PCB.
- 5) Replace the Pick-up.

### 1-2-2 Assembly

- 1) Replace the Pick-up.
- 2) Assemble the deck PCB.
- 3) Reassemble the deck.
- 4) Switch LD SW3 on deck PCB to 'O' and insert FPC into Main PCB CN1 (See Fig 1-2).

**Note :** If the assembly and disassembly are not done in correct sequence, the Pick-up may be damaged.

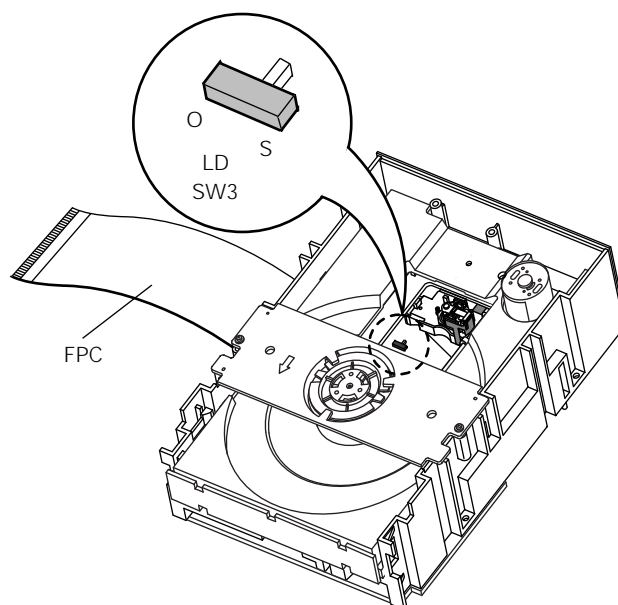

Fig. 1-2

## MEMO

### 3. Product Specifications

The specifications and design may be changed without notice. The weight and dimensions are approximate.

MODEL		DVD905
G E N E R A L	Power Requirements	120 Voltage, 60Hz
	Power Consumption	23W
	Weight	4.4Kg
	Set Size	(W)420mm x (D)339mm x (H)120mm
	Operating Temperature Range	+ 5 °C ~ 35 °C
	Operating Humidity Range	50% ~ 95%
D I S C	DVD (DIGITAL VERSATILE DISC)	Reading Speed ; 1.2 ~ 1.4mm/sec
		Maximum Play Time ; 135 minutes
	CD : 12cm (COMPACT DISC)	Reading Speed ; 1.2 ~ 1.4mm/sec
		Maximum Play Time ; 74 minutes
	CD : 8cm (COMPACT DISC)	Reading Speed ; 1.2 ~ 1.4mm/sec
		Maximum Play Time ; 74 minutes
VIDEO - CD 12cm	Reading Speed ; 1.2 ~ 1.4m/sec	
	Maximum Play Time ; 74 minutes(Video + Audio)	
V O I D E O U T	RCA JACK	2 channel ; 1.0Vp-p
		R(Red) ; 0.714Vp-p
		G(Green) ; 0.714Vp-p
		B(Blue) ; 0.714Vp-p
		S(Sync) ; 4.0Vp-p
	SUPER VIDEO	Luminance Signal ; 1Vp-p (75Ω load)
Color Signal ; 0.286Vp-p (75Ω load)		
A O U D I O U T	2 channel	L(1/L), R(2/R)
	5 channel	F/L, F/R, R/L, R/R, C/T, S/W
	Output Level	Analog ; 2Vrms(1KHz)
		Digital ; 5Vp-p
	Digital Frequency Response	* Frequency Response ; 4Hz ~20KHz, S/M Ratio : 105dB
		* <b>Dynamic Range ; 95dB</b>
* <b>Total Harmonic Distortion 0,005%</b>		

## MEMO

---

## 4. Disassembly and Reassembly

---

### 4-1 Exterior and PCB Disassembly

---

#### 4-1-1 Door-tray

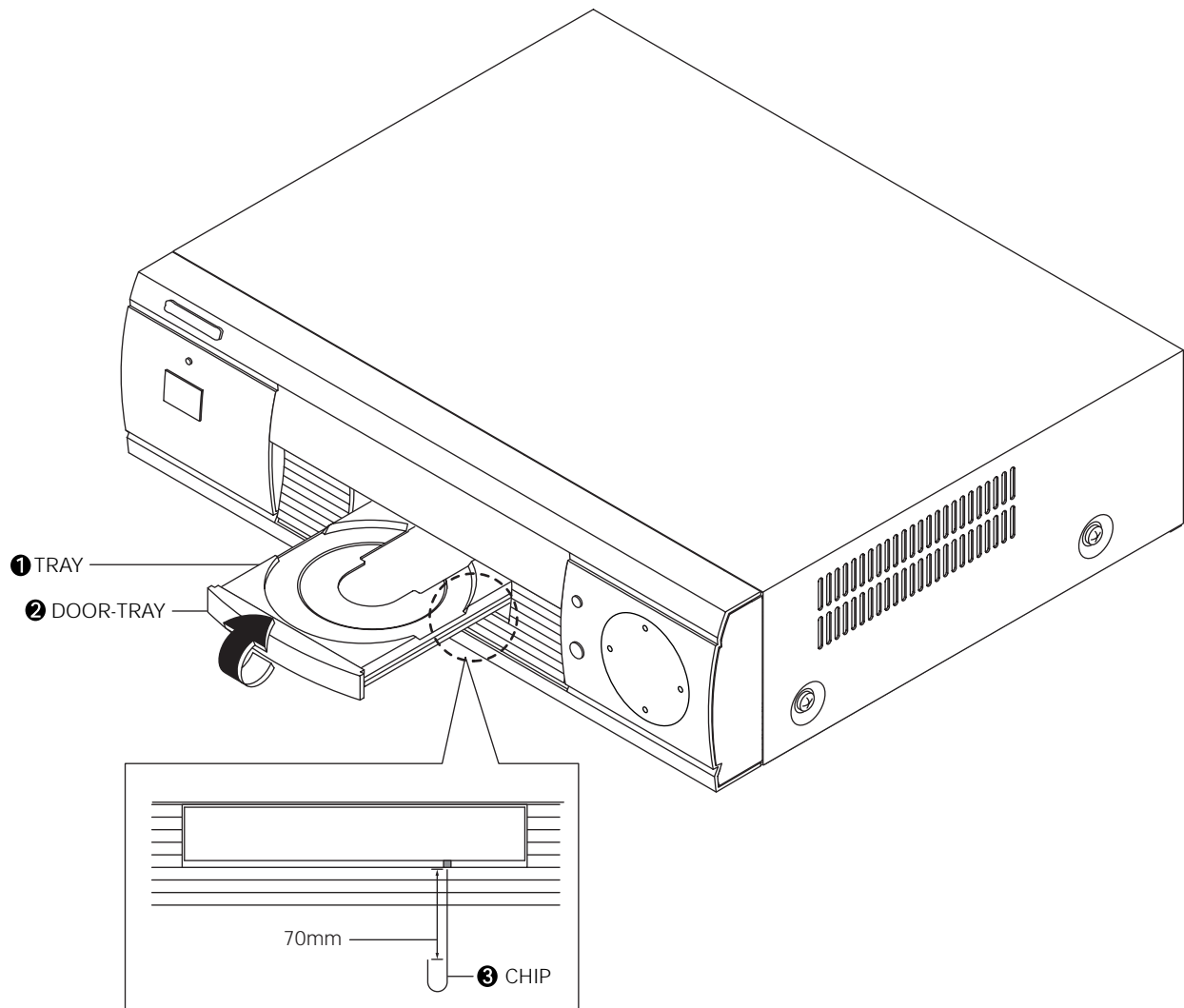

- 1) Supply power and open Tray ❶.
- 2) Disassemble the door-tray ❷ in direction of arrow.
- 3) Close Tray ❶ and power off.

**Note :** If Tray ❶ doesn't open, insert a clip ❸ into the hole (as shown in detailed drawing), and open Tray ❶ manually.

Fig. 4-1



## 4-1-2 Top cabinet

1. Remove 3 screws **1** on the back panel.
2. Remove 4 screws **2**, **3** on the left and right side.
3. Lift up the top cabinet in direction of arrow.

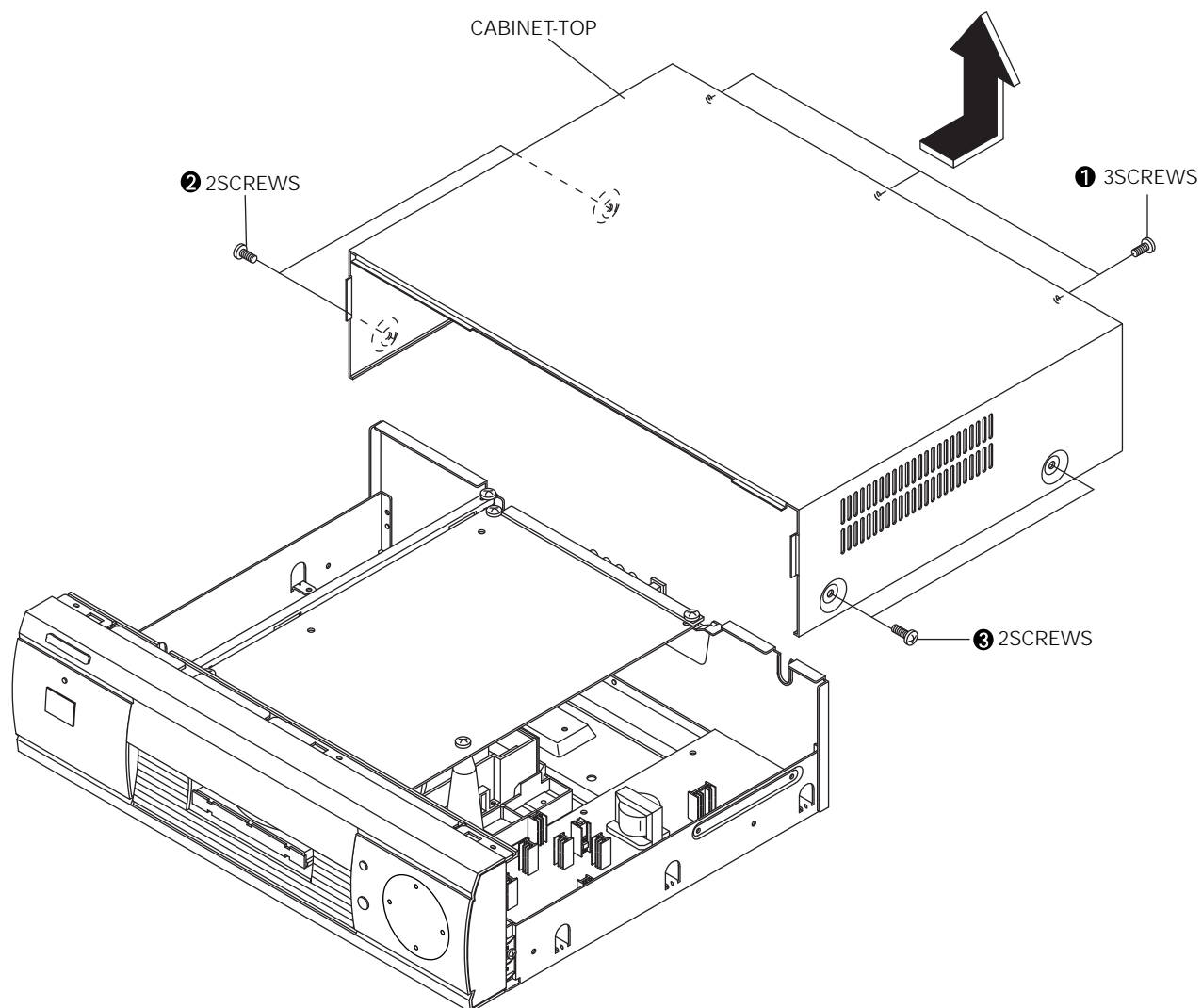

Fig. 4-2

### 4-1-3 Front

1. Remove 2 screws **1**, **2** on the left and right side of panel-front ass'y
2. Remove 2 screws **3** on the bottom of cover-panel ass'y and disassemble the front.
3. Remove 2 screws **4** from PCB-front.
4. Remove 9 hooks to fix PCB-front and disassemble PCB-front.
5. Remove 2 screws **5** on the top of cover-panel ass'y
6. Remove 4 top hooks **6** and 5 bottom hooks **7** and disassemble the cover-panel ass'y.

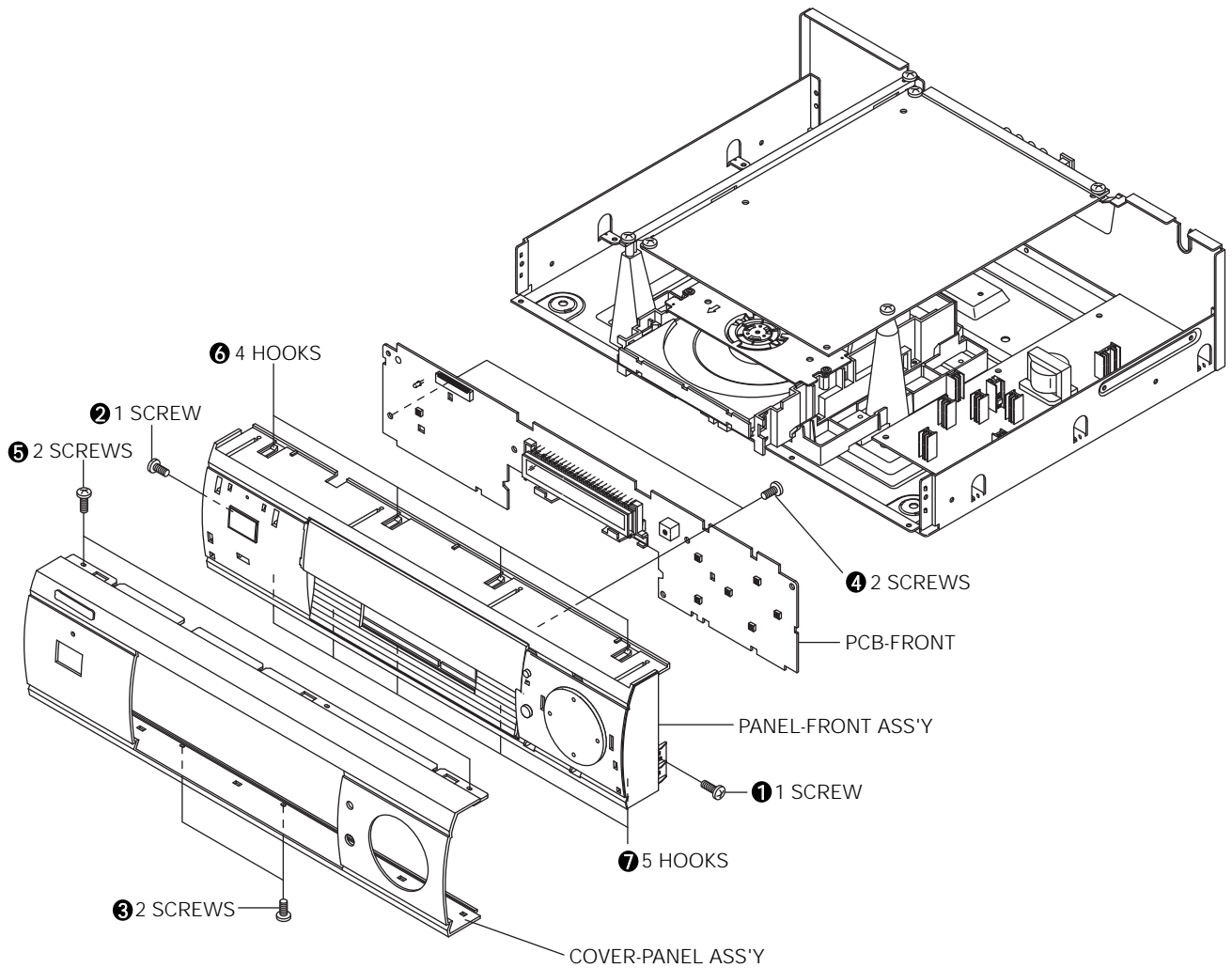

Fig. 4-3

#### 4-1-4 PCB-MAIN, PCB-SMPS

1. Remove 4 screws **①** to fix PCB-MAIN.
2. Remove 2 Holder-PCB **②** inserted in PCB-MAIN and lift up PCB-MAIN.
3. Remove 3 screws **③** from PCB-SMPS.
4. Remove 3 Spacer-PCB **④** inserted in PCB-SMPS and lift up PCB-SMPS.
5. Remove 2 screws **⑤** to fix BRKT-PCB ass'y.

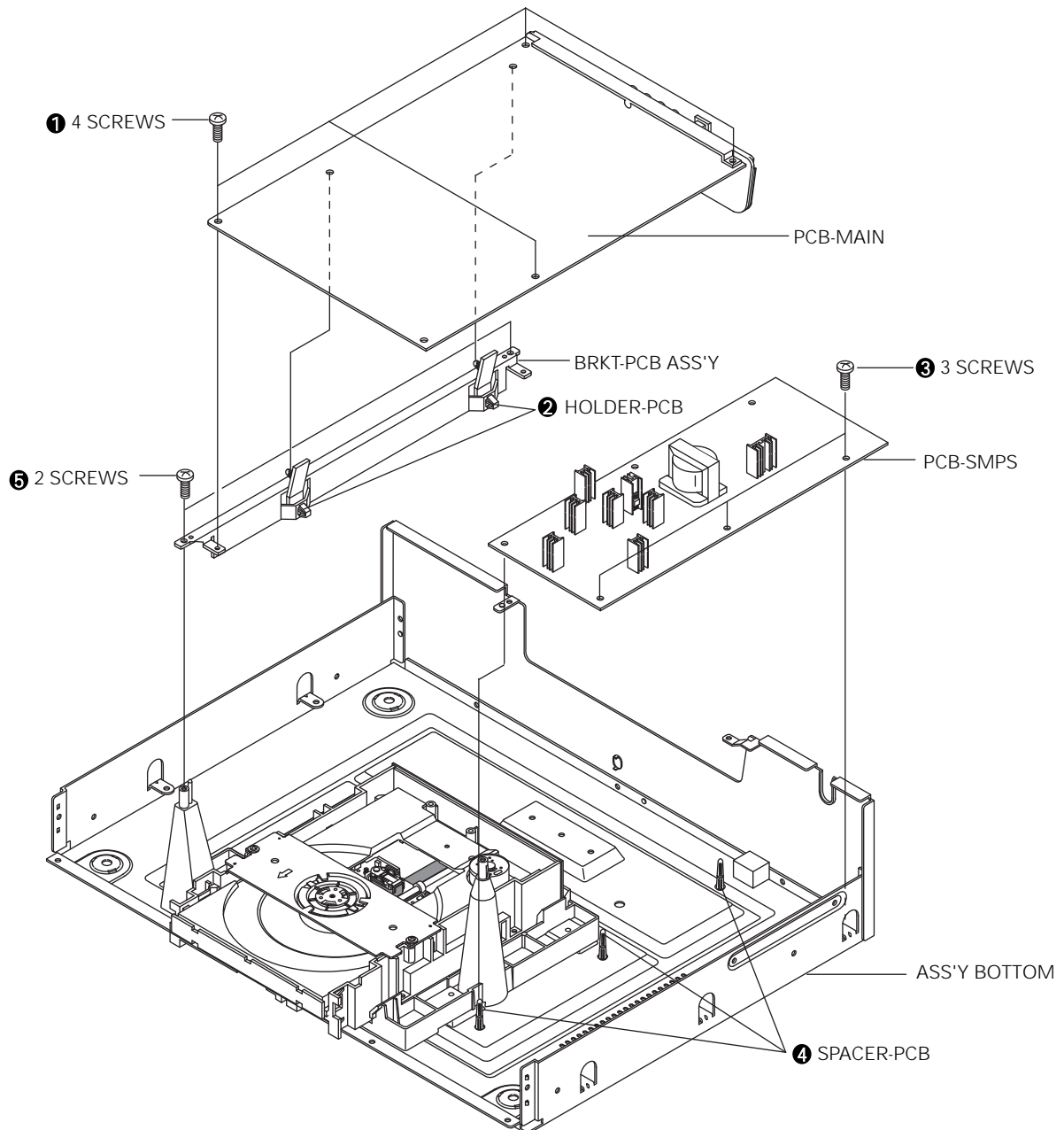

Fig. 4-4

### 4-1-5 Deck, Frame-chassis

1. Remove 4 screws **①** from the deck and lift it up.
2. Remove 4 screws **②** from the frame-chassis and lift it up.

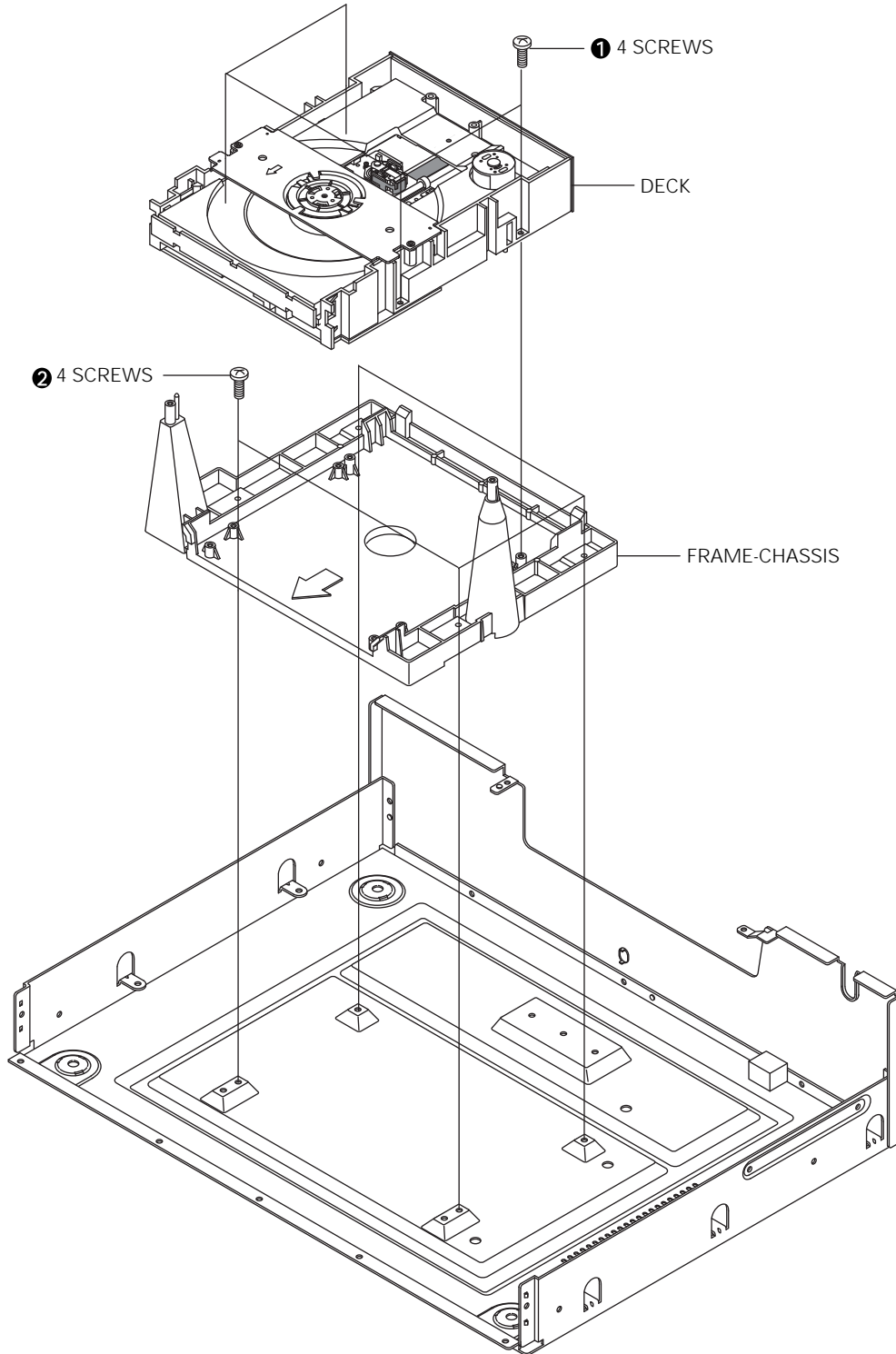

Fig. 4-5

## 4-2 PCB Locations

---

DVD905

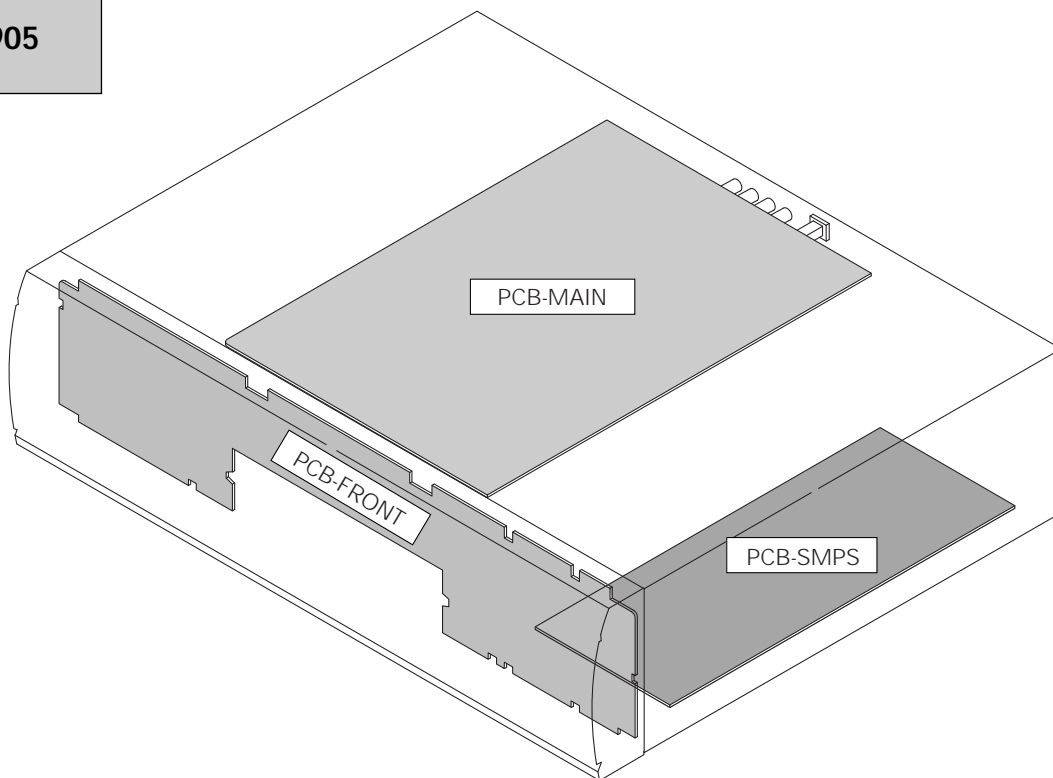

Fig. 4-6

4-2-1 DVD905

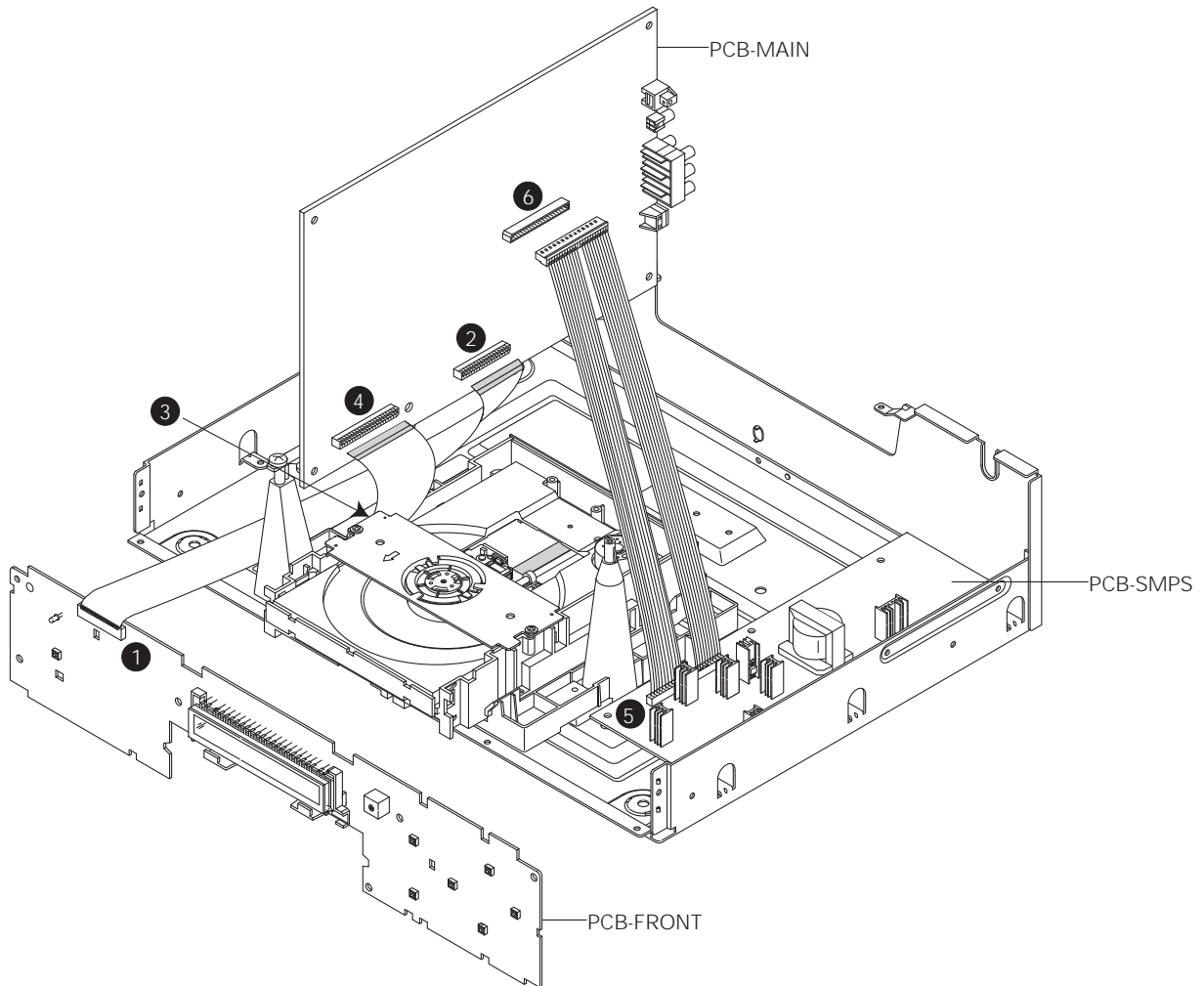

Fig. 4-7

No.	Connector wafer No.	Direction	Connector wafer No.
①	FCN1	PCB-FRONT → PCB-MAIN	VCN11
②	VCN11	PCB-FRONT	FCN1
③	CN5	DECK → PCB-MAIN	CN1
④	CN1	DECK	CN5
⑤	PCN02	PCB-SMP → PCB-MAIN	VCN13
⑥	VCN13	PCB-SMPS	PCN02

## 4-3 Deck Disassembly

### 4-3-1 Tray

1. Remove 2 screws **1** and lift up the ass'y-deck clamper **2**.
2. Insert a clip into Emergency hole, and push Gear-Cam Center **3**. When the tray **4** comes out a little, pull it in direction of arrow "C".
3. Pull the tray **4** to disassemble, while simultaneously pushing the hook **5**, **6** in direction of arrow "A", "B".

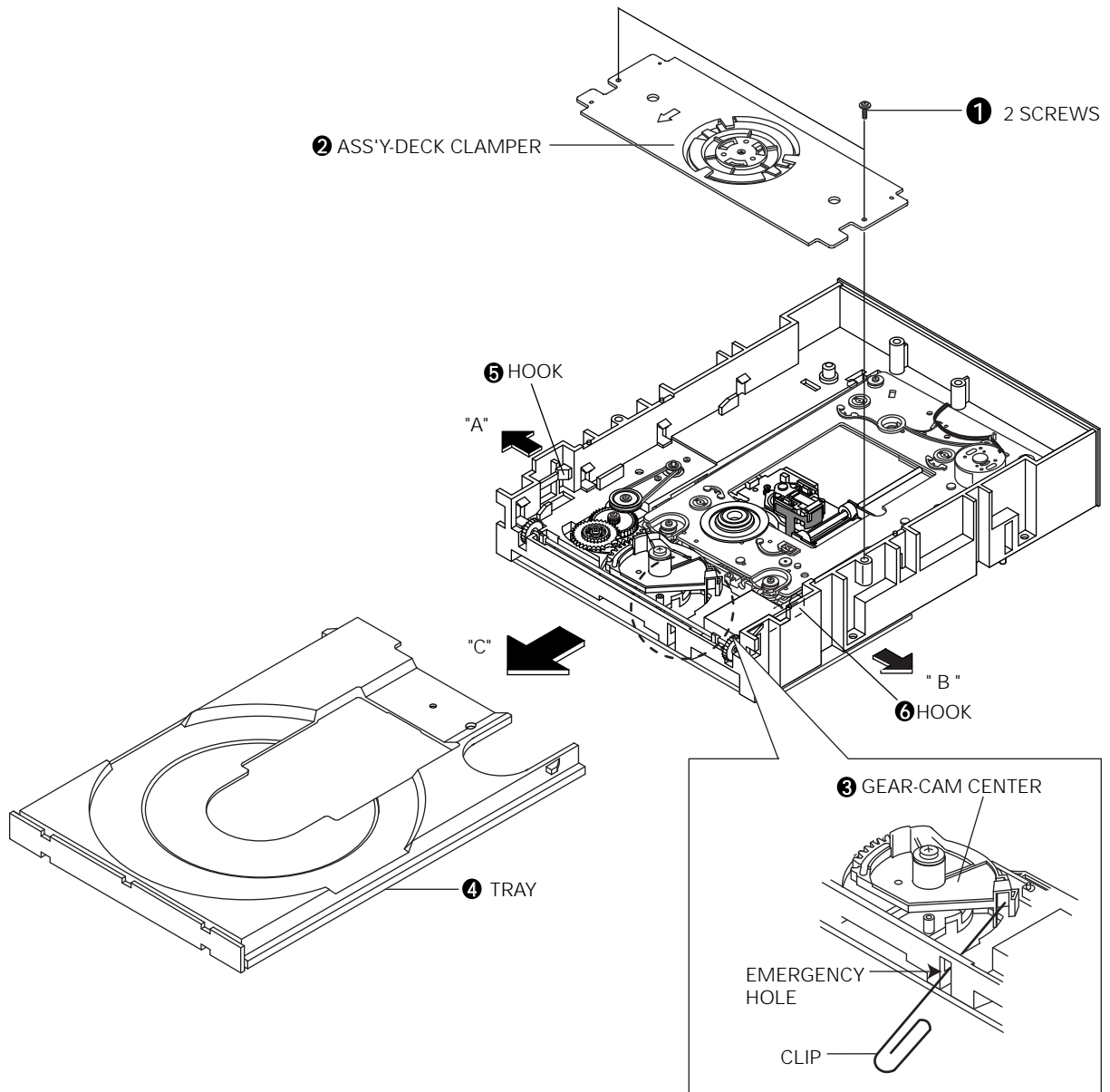

Fig. 4-8

### 4-3-2 Ass'y-Deck DVD

1. Remove 2 screws ❶ and disassemble the ass'y-PCB deck ❷.
2. Disassemble the ass'y-deck DVD ❸ in direction of arrow "B", while simultaneously pushing the hook ❹ in direction of arrow "A".

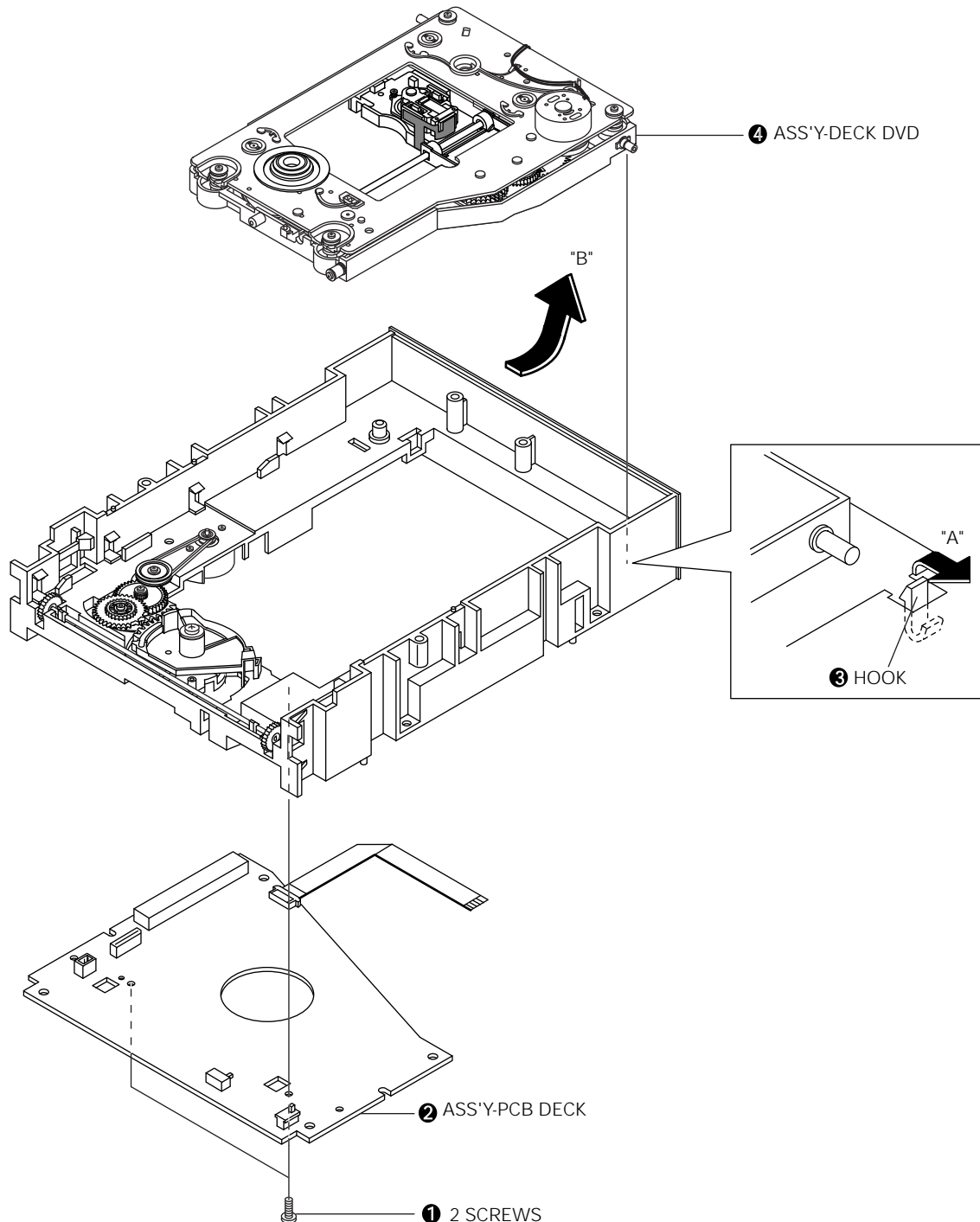

Fig. 4-9



### 4-3-3 Chassis-Main parts

1. Lift up the gear-tray ①, remove 1 screw ② and lift up the gear-cam center ③.
2. Lift up the belt-pulley ④, remove 1 screw ⑤ and lift up the pulley-gear ⑥.
3. Remove 1 screw ⑦ and lift up the gear-tray A ⑧ and gear-cam sub ⑨.
4. Remove 2 screws ⑩ and disassemble the ass'y-motor load ⑪.
5. Remove 1 screw ⑫ and disassemble the lever-open S/W ⑬.
6. Lift up the shaft-syncro ⑭ and remove the 2 gear-syncro ⑮ in both directions.

**Assembling :** Adjust the shaft end of motor-feed so that it is exactly equal to the height of the hump in gear pole of ass'y-gear magnet.

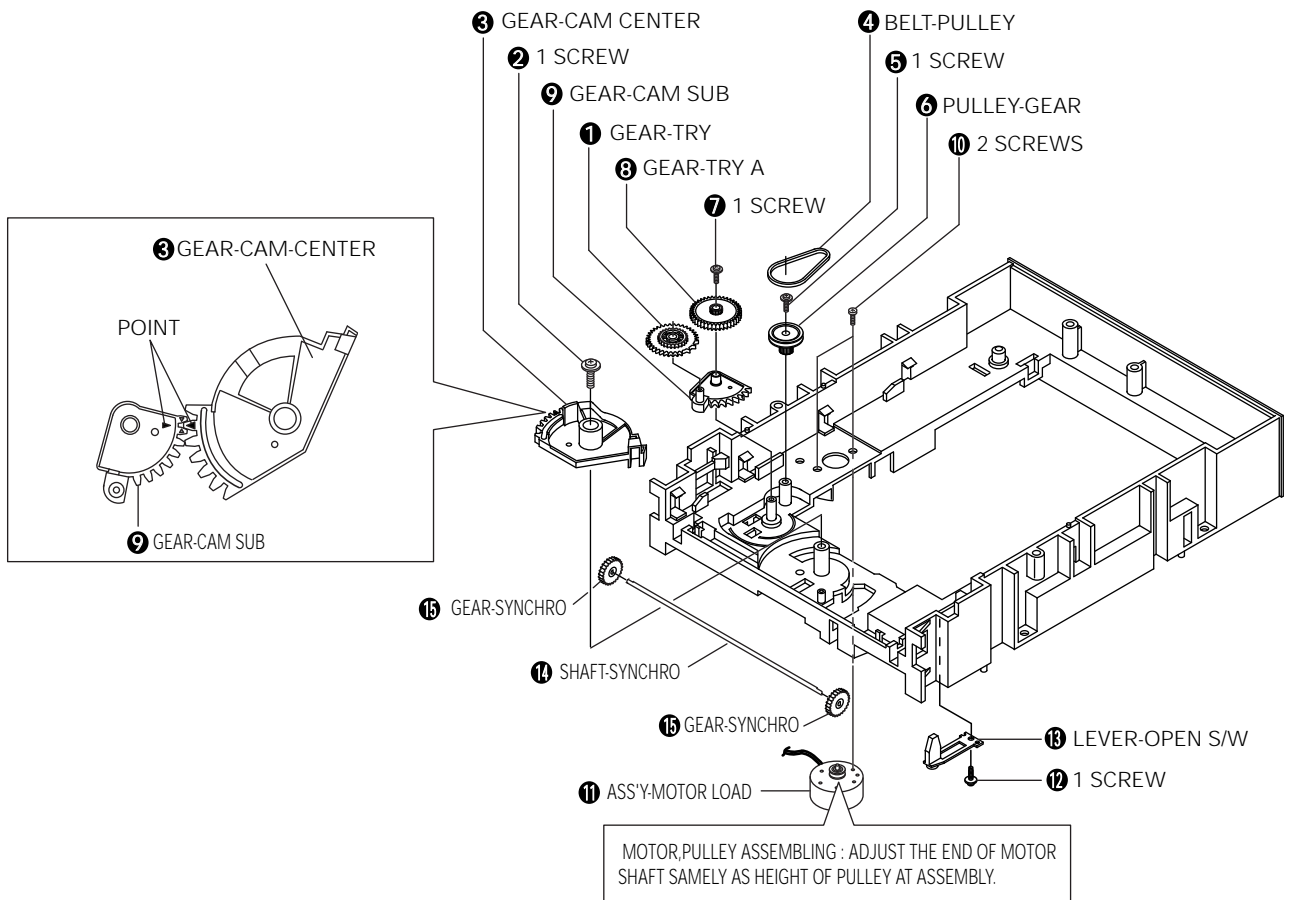

Fig. 4-10

### 4-3-4 Ass'y deck

1. Remove 4 screws ❶.
2. Lift up the ass'y-deck ❷.

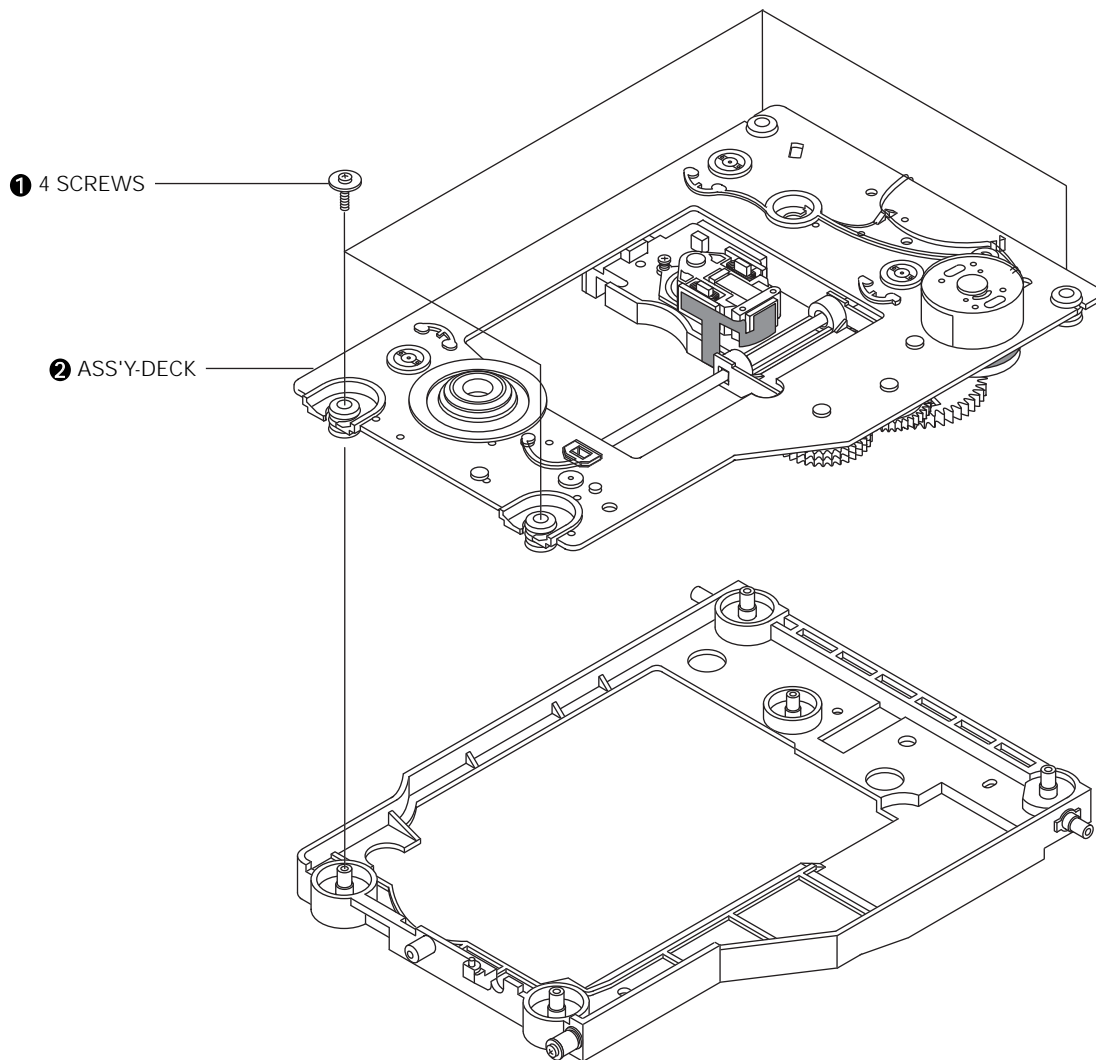

Fig. 4-11

### 4-3-5 Ass'y-Deck parts

1. Remove 3 screws ❶ and disassemble 3 holder-cams ❷.
2. Disassemble the rack-slide ❸ and ass'y-pickup ❹, while simultaneously removing the shaft-P/U-L ❺, shaft-P/U-R ❻.
3. Remove 3 screws ❼ and disassemble the ass'y-motor spindle ❽.
4. Remove the washer-plain ❾ and disassemble the ass'y-gear feed AU/AL ❿.
5. Remove the washer-plain ⓫ and disassemble the gear-feed B ⓬.
6. Remove the washer-plain ⓭ and disassemble the ass'y-gear feed CU/CL ⓮.
7. Disassemble the ass'y-gear magnet ⓯.
8. Remove 2 screws ⓰ and disassemble the ass'y-PCB hall sensor ⓱.
9. Remove 1 screw ⓲ and disassemble the motor-feed ⓳.

**Assembling :** Adjust the shaft end of motor-feed ⓳ so that it is exactly equal to the height of the hump in gear pole of ass'y-gear magnet.

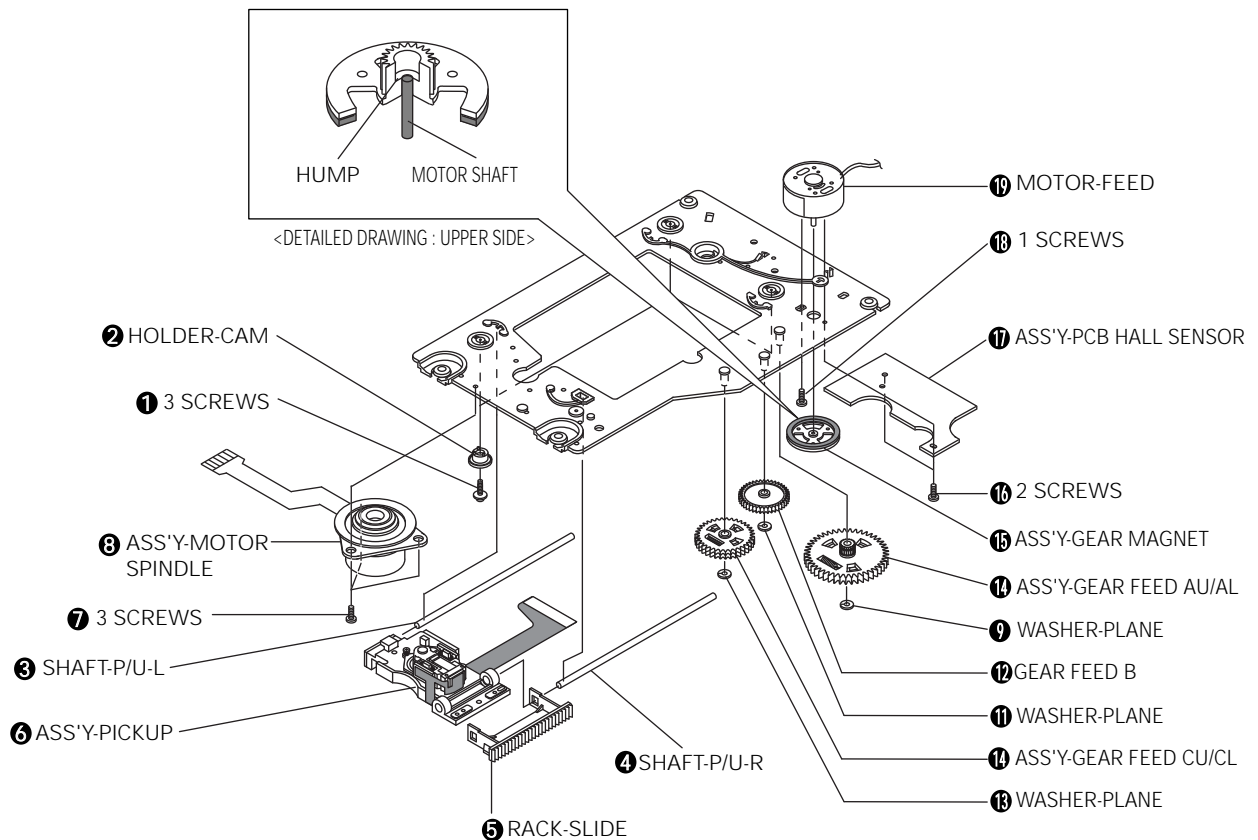

Fig. 4-12

## 2. Circuit Operating Description

### 2-1 SMPS circuit description

#### 2-1-1 Comparison between linear power supply and SMPS

##### 2-1-1(a) LINEAR

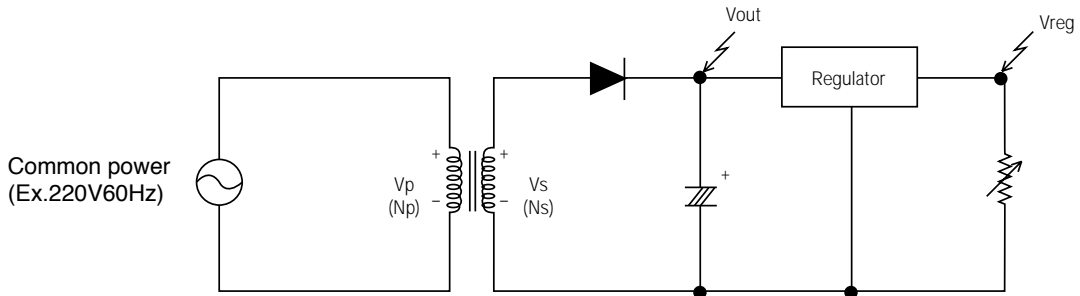

Fig. 2-1

##### ◆ Waveform/Description

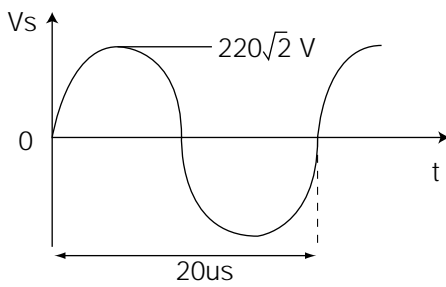

Fig. 2-2

Input : Common power to transformer ( $V_p$ )

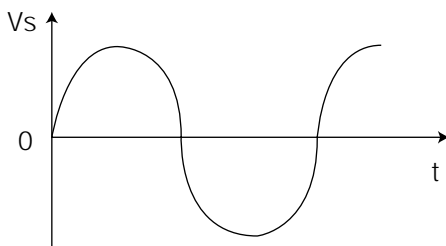

Fig. 2-3

The output  $V_s$  of transformer is determined by the ratio of 1st  $N_p$  and 2nd  $N_s$ .  
 $V_s = (N_s/N_p) \times V_p$

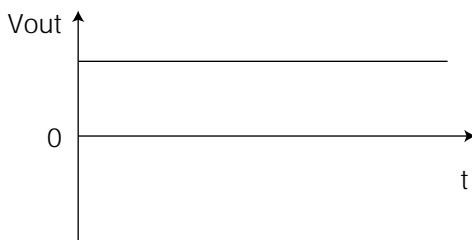

Fig. 2-4

$V_{out}$  is output (DC) by diode and condenser.

◆ Advantages and disadvantages of linear power supply

a. Advantages :

Little noise because the output waveform of transformer is sine wave.

b. Disadvantages :

- » Additional margin is required because  $V_s$  is changed (depending on power source). (The regulator loss is caused by margin design).
- » Greater core size and condenser capacity are needed, because the transformer works on a single power frequency.

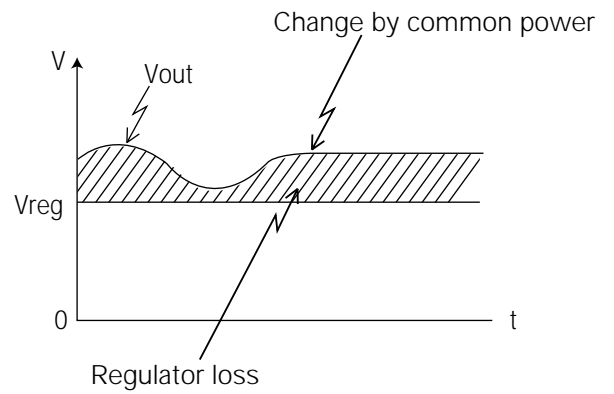

Fig. 2-5

2-1-1 (B) SMPS(PULSE WIDTH MODULATION METHOD)

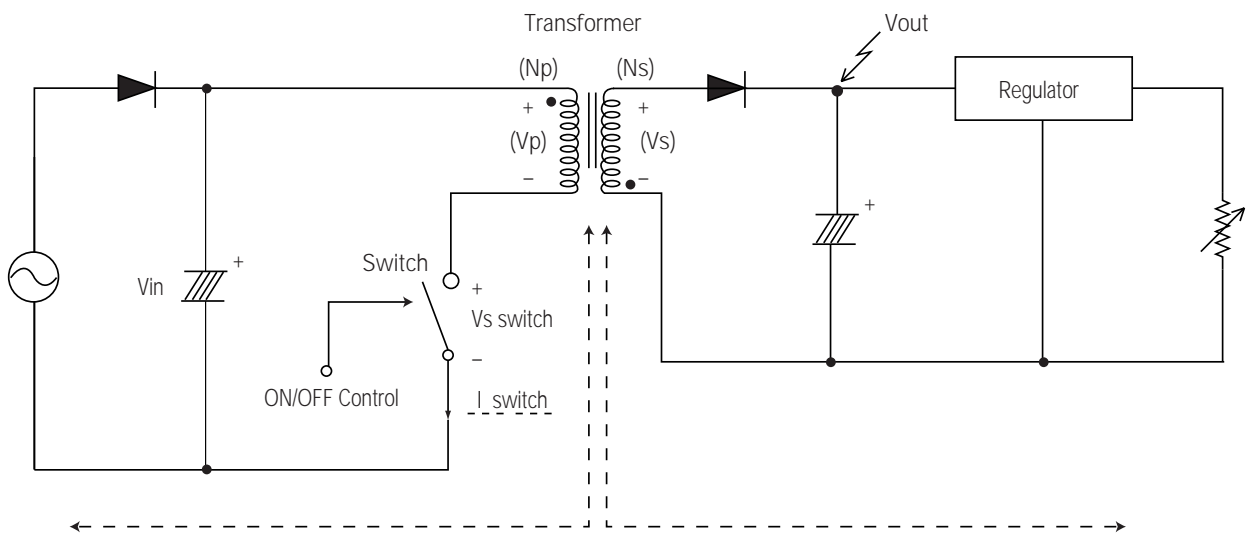

Fig. 2-6

◆ Terms

- 1st : Common power input to 1st winding.
- 2d : Circuit followings output winding of transformer.
- f(Frequency) : Switching frequency(T : Switching cycle)
- Duty :  $(T_{on}/T) \times 100$

◆ Waveform

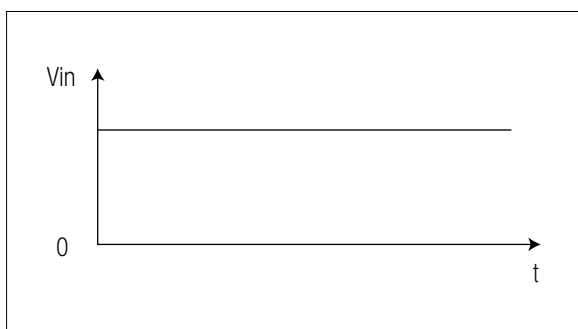

Fig. 2-7

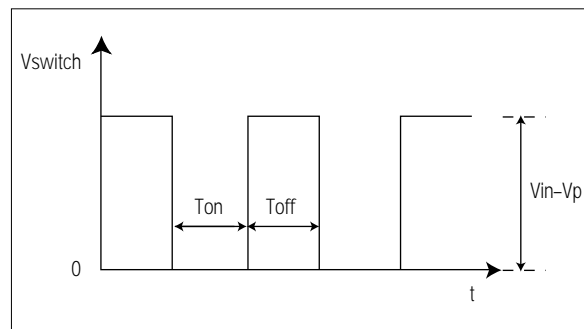

Fig. 2-11

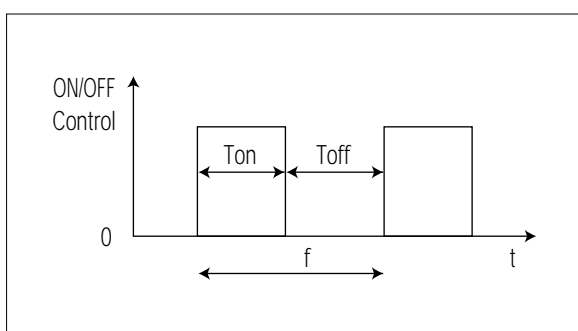

Fig. 2-8

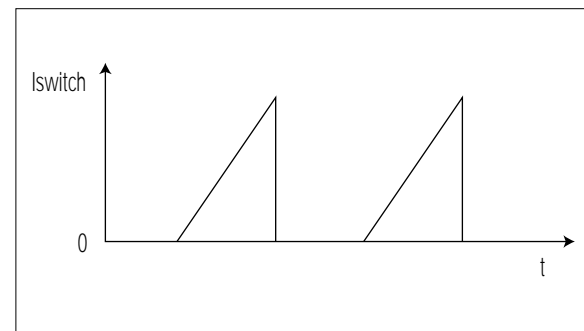

Fig. 2-12

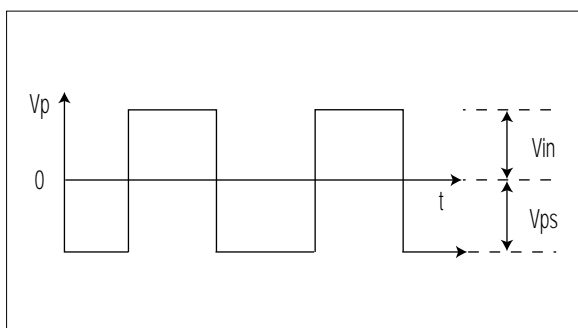

Fig. 2-9

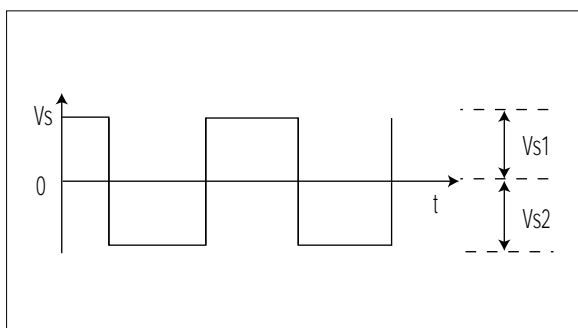

Fig. 2-10

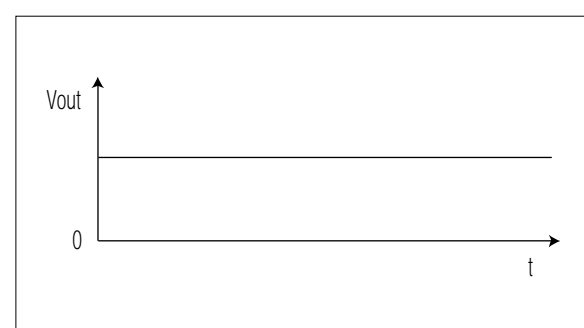

Fig. 2-13

2-1-1(c) INTERNAL BLOCK DIAGRAM

1. Internal block diagram of SMPS circuit

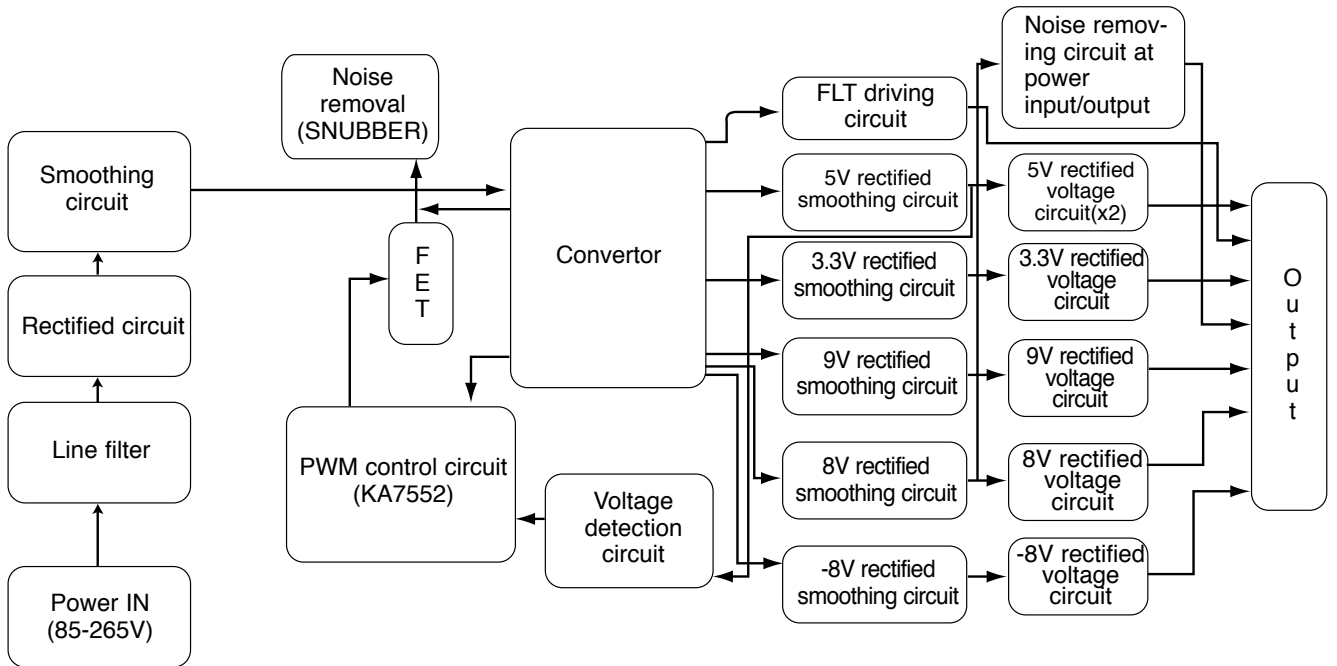

Fig. 2-14

2. PIC1(KA7552) internal block diagram

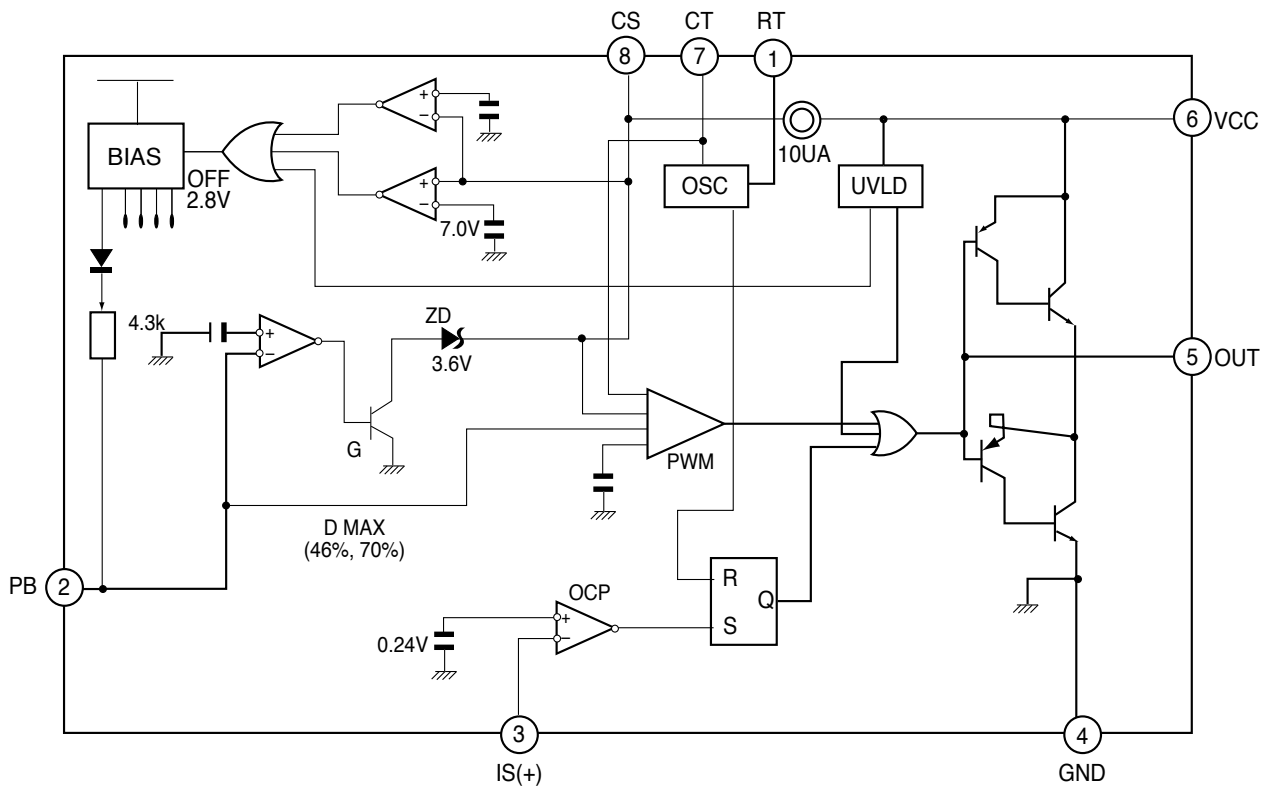

Fig. 2-15

## 2-1-2 SMPS circuit description

### 2-1-2(a) CIRCUIT METHOD

FLY-BACK PWM(Pulse width modulation) control

### 2-1-2(b) CIRCUIT DESCRIPTIONS

#### 1. AC power rectification/smoothing terminal

- PD01 : Convert AC power to DC(Wave rectification)
- PO10 : Smooth the voltage converted to DC(Refer to Vin of Fig. 2-7)
- PC01, PC02, PC03, PC04, PC05, PC06, PL01, PL02, PL03 : Noise removal at power input/output
- PVA1 : SMPS protection at power surge input
- PVA2 : SMPS protection at 2st ground surge input(PVA1 pattern open : to remove noise)
- PR10 : Rush current limit resistance during power cord insertion.
  - » Rush current = (AC input voltage × 1.414 - Diode drop voltage) / Pattern resistance + PL02.01 resistance + PC10 resistance + PR10) (AC230V based : approx. 26A)
  - » Without PR10, the bridge diode might be damaged as the rush current increases.

#### 2. SNUBBER circuit : PR17, PR18, PC11, PD10

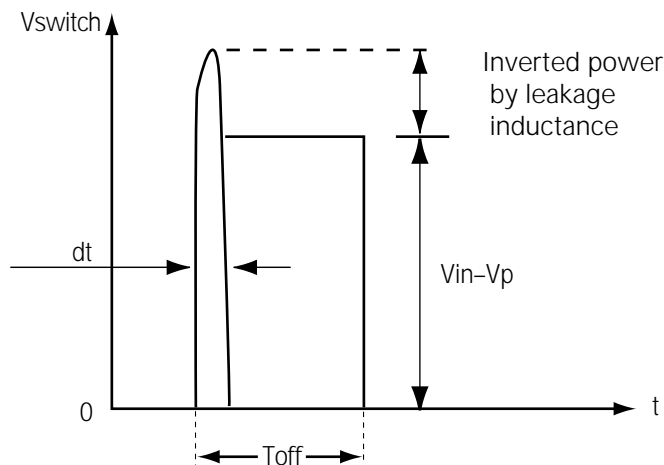

Fig. 2-16

- Prevent residual high voltage at the terminals of switch during switch off/Suppress noise. High inverted power occurs at switch off, because of the 1st winding of transformer: ( $V=L1 \times di/dt$ . LI : Leakage Induction) A very high residual voltage exists on both terminals of PQ1 because  $dt$  is a very short.
- SNUBBER circuit protects PQ1 from damage through leakage voltage suppression by RC, (Charges the leakage voltage to PD10 and PC11, and discharges to PR17 and PR18).
- PC12, PL11 : For noise removal

#### 3. PIC1 Vcc circuit

- PR11, PR12, PR13, PR14 : PIC1 driving resistance (PIC1 works through driving resistance at power cord in)
- PIC1 Vcc : PR20, PD12, PC17
  - 1) Use the output of transformer as Vcc, because the current starts to flow into transformer while PIC1 is active.
  - 2) Rectify to PD12 and smooth to PC17.
  - 3) Use the output of transformer as PIC1 Vcc : The loads are different before and after PIC1 driving. (Vcc of PIC1 decreases below OFF voltage, using only the resistance due to load increase after PIC1 driving.)
- PR20 : For noise removal



## 4. PIC1 function : PWM control (Refer to Switch ON/OFF Control of Fig. 2-6)

PIN	NAME	CLASS	SPEC.	FEATURES
1	RT	-	0.56V	* Resistance to determine OUT terminal(pin5) ON/OFF control frequency - Determined with CT terminal(pin7) and for DVDP, 50KHz RT : PR24, CT : PC13
2	F/B	-	-	* OUT terminal duty is determined by F/B potential (Duty control : 2st output constant-voltage control) * The voltage of PIC2(Output voltage feedback) is input to F/B terminal.
		OFF voltage	0.75V	* If F/B terminal potential decreases below 0.75V, OUT duty is zero. - SMPS 2st output voltage is zero.
		SHUT OFF voltage	2.8V	* If F/B potential is above 2.8V, CS terminal(8pin) potential ascends in IC. If CS potential rises above 7V, SHUT OFF mode is maintained.
		DUTY MAX voltage	2.3V	* SHUT OFF mode : IC internal bias OFF state.(Operation stop)
3	IS	LIMIT voltage	0.24V	* If IS terminal potential is above 0.24V, maintain on time only when IS terminal potential is 0.24V without holding OUT duty determined in F/B terminal(Duty limit). * PQ1(F,E,T) current is distributed to PR22, PR21 in voltage, and input to IS terminal. * Purpose : Limit the overcurrent of PQ1(Current waveform : See Fig. 2-10)
4	GND	-	-	* Ground(SMPS 1st ground)
5	OUT	-	-	* ON/OFF control pulse output terminal(f : fixed, ON TIME : variable)
		Maximum DUTY	70%	* Maximum duty is 70% (Maximum).
6	VCC	ON voltage	16V	* IC power supply terminal. IC function starts at exceeding 16V. Vcc less than 8.7V will be OFF after IC working.(See Clause 3. Vcc circuit) - Vcc voltage is 10-12V at normal operation.
		OFF voltage	8.7V	
7	CT	-	-	* ON/OFF frequency determining terminal(Refer to 1 pin RT terminal)
8	CS	OFF voltage	0.42V	* OS potential setting : Connect the condenser to OS terminal(PC14) * ON/OFF control : If CS potential is above 0.56V, IC function starts and if below 0.42V, IC function stops. * At normal operation : Maintain 3.6V in IC * SHUT OFF mode : If CS potential is above 7V, shut off.(Overload prevention) - SHUT OFF function : When IS, F/B, CS terminal are all operated normally. (Refer to Clause 6. MAX. POWER limiting circuit) * SOFT START : Switch protection at initial starting - F/B potential is 3.6V internally at initial starting.(Duty max.) - PQ1 damage occurs due to overcurrent on switch at duty max. - CS terminal sets the duty with F/B terminal - Connect PC14 to CS terminal and set the voltage charging time at initial starting. - Increase the duty by raising the voltage gradually via PC14 at initial starting for normal operation. (Duty max. is limited by F/B potential at initial starting)
		ON voltage	0.56V	
		Normal operation voltage	3.6V	
		SHUT OFF voltage	7V	
		MAX DUTY voltage	2.3V	

## 5. Feedback control circuit

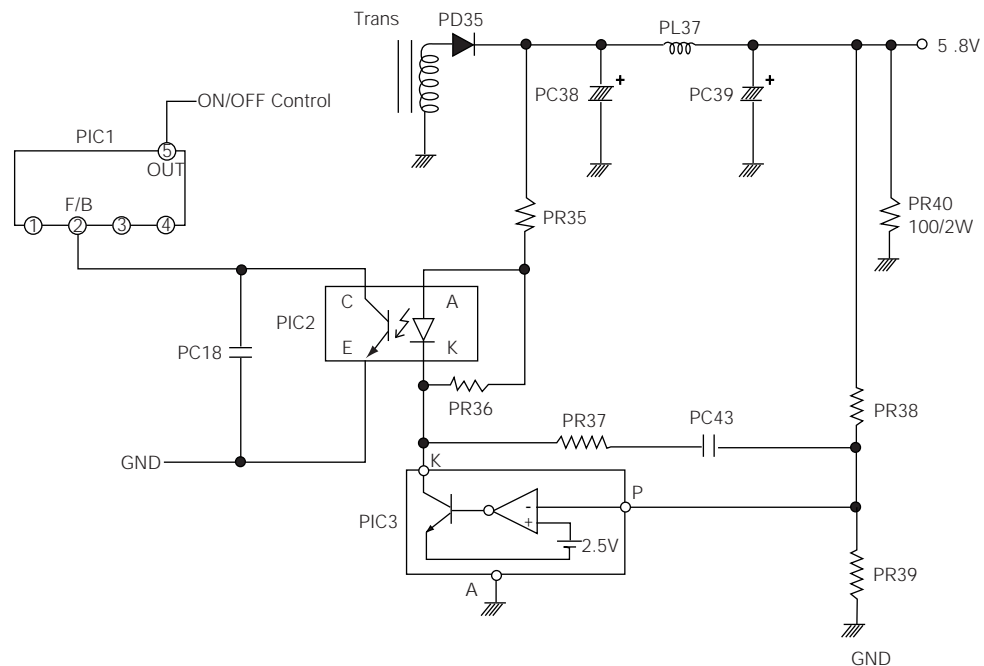

Fig. 2-17

- F/B terminal of PIC1 determines output duty cycle.
- Duty definition : Refer to Vs1 in Fig4-10.(Duty up: Vs1 up, Duty down: Vs2 down)
- C-E(Collector-Emitter) of PIC2 and F/B potential of PIC1 are same.
- At F/B terminal open : SHUT OFF mode
  - » F/B potential is set to 3.6V internally.
  - F/B potential decreases to 1-2V by C-E voltage of PIC2 ( controlled by normal operation. )
  - » When F/B terminal is open, shut off occurs because 2.8V is exceeded.
  - (Refer to clause 4.)

## ◆ Operation descriptions

- a. Internal OP-Amp '+' base potential of PIC3 is 2.5V and external "-" input potential is connected with PR38 and PR39 to maintain Vout of 5.8V. ( $V_{out} = ((PR36 \times PR39) / PR39) \times 2.5V$ )
- b. If load of 5.8 V terminal increases(or AC input voltage decreases) and Vout decreases below 5.8V, then :  
 PIC3 'P' potential down below 2.5V --> PIC3 A-K of base current down --> PIC3 of A-K current down -->  
 PIC2 Diode current down --> PIC2 C-E current down --> PIC2 C-E voltage up --> PIC1 F/B voltage up -->  
 OUT Duty up --> Transformer 1st current up --> Transformer 1st power up --> Vout up --> Maintain  
 Vout 5.8V
- c. If load of 5.8 V terminal decreases(or AC input voltage rises) and Vout rises above 5.8V, then :  
 Reverse sequence of the above description → Duty down → Vout down → Maintain 5.8V  
 (i.e., the feedback to maintains 5.8V).
  - PR35, PR36 : Reduce 5.8V overshoot
  - PR37, PC43 : Prevent IC3 oscillation(for phase correction)
  - PC18 : Adjust feedback response rate

6. Maximum power limit circuit

- \* Circuit configuration : PIC1 F/B, CS, IS terminal PR23, PR21, PR22, PC13A
- \* Role : Switch overcurrent protection
- \* The current on switch inputs to IS and outputs as voltage via PR23, PR21, PR22.
- \* If the current on switch increases and IS terminal input voltage exceeds 0.24V, duty is determined by F/B terminal. Accordingly, the current on switch is limited less than specific current.(If 2d load rises, the switch current increases. Refer to clause 5. in circuit description).
- \* If I/S terminal is open : Switch and other parts are damaged because the switch is not limited during abnormal status (for example, 2d output terminal short).

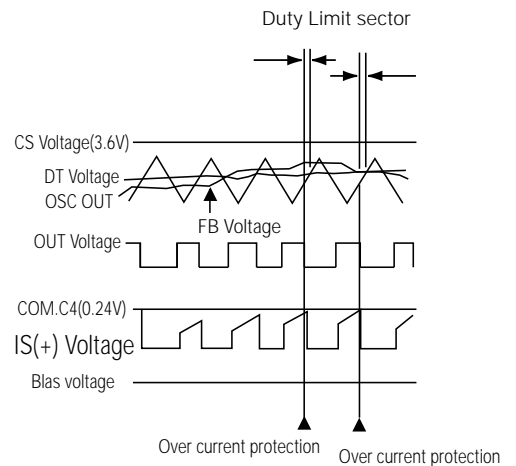

Fig. 2-18

1) Intermittent operation mode

- Definition : PIC1 can't deliver normal output, and repeats Vcc ON/OFF operation(Vcc voltage is swing between 16V(ON) and 8.7V(OFF)).
- Operation description : for example. 2d output terminals shorted, then :  
 Specific 2d terminal short --> 2d power is concentrated on short terminal --> 5.8V(PC39) voltage down --> F/B voltage up (Refer to clause 5.) --> Duty up --> Switch current up --> Limit switch current to IS terminal(Duty limit) --> Apply 1st supply power in comparison with 2d power --> Concentrate on 2d power short terminal --> PIC1 Vcc terminal TRANS. output voltage down below 8.7V --> PIC1 OFF --> PIC1 ON via driving resistance --> Above operations repeated → Maintain intermittent operation mode (See Fig. 2-19 Waveform).  
 At short release : normal operation

2) Short OFF mode

- Main examples : Feedback circuit Open, Max, Power excess(Design spec.), 5.8V Terminal short
- Operation description :  
 Ex - 2d load is high abnormally;  
 1st supply power is low in comparison with 2d output power.  
 5.8V down --> Duty up --> Switch current up -->  
 IS terminal duty limit --> 1st supply power limit --> 5.8V voltage down --> F/B potential above 2.8V(Shut OFF voltage) --> OS terminal potential up (Refer to Clause 4.)F/B --> OS potential above 7V --> Shut OFF mode
- The output voltage of SMPS is zero because PIC1 doesn't work during Shut OFF mode.
- Shut OFF mode release : OS potential decreases below 7V.(Charge OS terminal forcibly)
- Feedback terminal open : Shut OFF (Refer to clause 5.);  
 PC13A : For IS terminal input noise removal

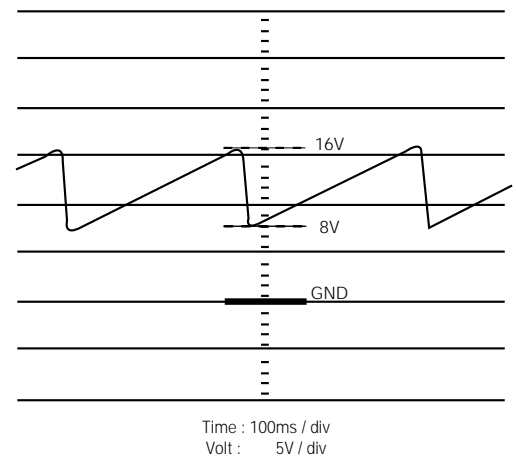

Fig. 2-19

## 7. Shut Off mode prevention circuit at instant load increase : PC15, PZD13

- During a sudden load increase;  
By means of current concentration on specific output terminal, 5.8V voltage down --> F/B potential up --> Maintain Shut Off mode.  
Stablize F/B potential (Loading completion) below 7V by lengthening CS potential rise time to 7V (in order to prevent Shut Off mode).
- Normal operation : CS potential is 3.6V and PZD13(4.7V ZENER) is open.
- OD potential above 4.7V at instant load increase --> PZD13, PC15 work --> OS terminal condenser capacity increases in parallel with PC14 and PC15 --> CS potential rising rate down --> Instant operation completed --> F/B potential stable --> Normal operation

## 8. Maximum power limiting circuit addition : PZD11, PR19

- SMPS efficiency : Below 25W : High efficiency at AC110V input  
Above 25W : High efficiency at AC230V input
- The peak value of current on switch at overload is lower than that at 110V input because SMPS is highly efficient above 25W at 230V input. Therefore, maximum power increases at 230V as compared to 110V at overload. Add PZD11, PR19 and set to the same level as 110V.
- Higher at 230V input than at PZD11 input, limit maximum power because IS terminal potential goes up.

## 9. PQ1(F,E,T) Gate Drive Circuit : PR15, PR16, PD11

- PIC1 OUT is square wave but charging and discharging by PR15, PR16 occurs due to internal condenser between gate-sources of PQ1.
- PR15, PR16 : Switch ON Time setting - PD11 is reverse : PIC1 OUT --> PR15 --> PR16 --> Charge to gate
- PR16, PD11 : Switch OFF Time setting - PD11 is proper : GATE - PR16 --> PD11 --> Discharge to PIC1 OUT(GND)
- Switch ON/OFF time : Related to switch loss and noise

## 10. PIC1 overcurrent protection : PZD12

- Operate PZD12 and protect PIC1 from damage from residual overcurrent (PIC1 Vcc, due to external surge inflow and feedback line open).

## 2-2 RF circuit description

### 2-2-1 RIC1(TA1236F)

TA1236F is combined with TA1253FN, TC9240F and TC90A19F as bipolar IC developed for DVD SERVO system. Main features include DVD waveform equalizing, CD waveform equalizing, focus error signal generation, 3-beam tracking error signal generation, laser power control, etc. after receiving the pick-up output converted into I/V.

#### 1. Basic potentiometer

TA1236F uses a single power method and each circuit is based on  $V_{REF}$  of 2.1V. Note : symmetrical about GND for  $V_{REF}$  because  $V_{REF}$ (pin20) terminal is needed for IC, which uses the peripheral  $V_{REF}$  and  $2V_{REF}$  output(pin18).

#### 2. RF signal

Fig. 2-20 shows the flow of signal generated by the pick-up.

A, B, C, D signals detected from pick-up are converted in to RF signal(A+B+C+D) via RF summing AMP.

RF signal is inputted to RFN(pin55) among input terminals and RFP(pin54) is used for AC ground.

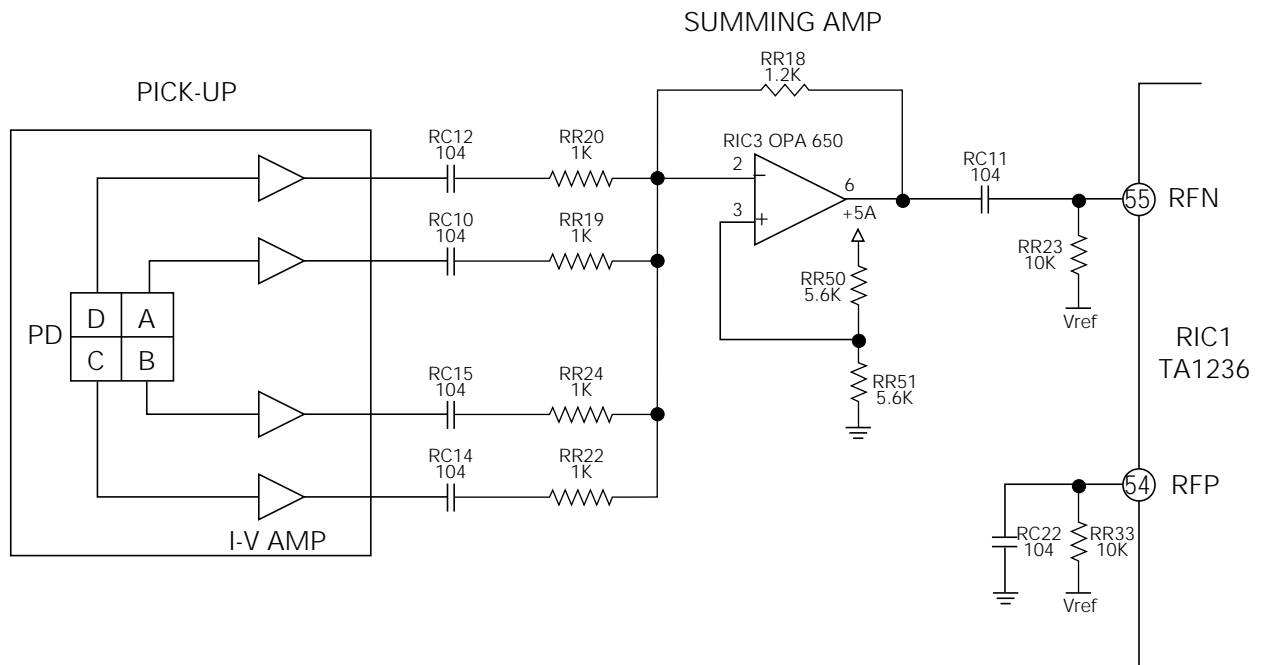

Fig. 2-20

Fig. 2-21 shows the waveform-equalizing block diagram for the RF signal.

It outputs to EQout(pin 46) terminal by initially changing switching AMP gain of DVD and CD, and then adjusting the level in VCA. It controls VCA gain by means of RF gain(pin 48) and interfaces with PWM signal, (output from RFGC terminal of TC9420F, via low-pass filter to constitute a loop for adjustment of constant amplitude). The gain in EQout is 1.0 for DVD and 1.67 for CD.

EQout terminal is connected with EQin(pin 45) externally, and inputs into DVD EQ and CD EQ(Waveform equalizing circuit).



## 2. Operation

### 1) Input circuit

RF data equalized in RF stage is AC-coupled via pin 50 and input as 2.1V<sub>pp</sub>. Then, the bias voltage becomes 1.65V by means of DC bias in IC.

### 2) PLL circuit

The input data generates the clock necessary for the PLL circuit. PLL circuit for clock generation generates the phase error signal through RLLD (pin 38), PDOP (pin 37), PDON (pin 36). The loop filter consists of built-in OP Amp and external parts.

The RLLD signal occurs only when the velocity difference between clock and data is large, and it sets the PLL operational velocity. RLLD signal doesn't occur at normal play except during searches

### 3) Data slicer

As the PLL generates the clocks, the slice circuit converts the analog signal to digital. that is, it switches to 1 if greater than regular reference voltage, and to 0 if less. The sliced signal may be observed at pin 34 (ED7) with a scope. If the signal has an error, it is necessary to check that the bias of input RF signal is correct, as well as the condensor at pin 42 (SLCO).

### 4) CLV circuit]

The signal is input to the circuit which generates DMO and CLV signals to control the rotation of the spindle motor. The control signal is output via pin 54(DMO). Then, the output signal is the 3d signal (a pulse derived from the midpoint voltage). If an error occurs in spindle motor during DVD play, check this signal.

### 5) Modulation and ID. Sync detection

The signal is synchronized, using the generated clocks, and Sync. signal is detected through Sync. signal detection circuit for modulation and all other signal processes. Sync. signal can't be observed externally, but the interrupt at each 1.4ms cycle may be checked on pin 23 (during normal detection, the interrupt signal is generated periodically). It is difficult to precisely define 1.4ms cycle, because other interrupts are also occurring.

During Sync. detection, the recorded signal is converted to data by means of an 8/16 modulation circuit.

The modulated signal is saved in memory, and interfaced externally for error correction.

### 7) Error correction circuit]

The data saved in external buffer memory after modulation are read by data processor sequentially for error correction. The data with all corrections are output by request of the next stage (video decoder).

### 8) VBR buffering]

The disc jumps the track repeatedly on waveform while checking each signal during normal play of DVD because it uses the VBR method (completely different from existing CD, video CD, etc). VBR play method enhances the data efficiency to improve the screen quality twofold, by using additional data for complex video and less data for simple video at compression. It saves the data in memory, and if the memory is full, it stops the play instantly to reset. If the data is removed, it repeats play because the play velocity varies according to data compression ratio. This process is known as VBR, and the used memory is known as the track buffer (or VBR buffer). A 4MIT DRAM attached to data processor includes this function.

### 9) Protection circuit]

Read if protected, and key for protection release from Read-in area (starting at first disc play). These operations are performed by TC6804 automatically.

Protection IC is located between output of data processor and input of video decoder, (the next stage).

it decodes the protected data after recognizing the key information read from disc and data status. If a disc violates the protection method, it stops the operation and reports to Micom.

## 2-3 System control circuit description

---

### 2-3-1 Outline

The main micom peripheral circuit is composed of 16bit Micom, 2M EPROM for Microcord and data save, 1M SRAM for data read/write on running, 512 byte EEPROM for permanent storage of data needed at power off, MIC4(74AC573) to latch only address in the bus where address and data are mixed, address decoder for selection of external device chip and 20MHz clock oscillator for micom operation. The micom(MIC1, TMP93CS41) mounted in main board analyzes the key commands of front panel or instructions of remote control through communication with micom(FIC1, LC86P6232) of front and controls the devices on board to execute the corresponding commands after initializing the devices connected with micom on board at power on.



### 2-3-2 System control block diagram

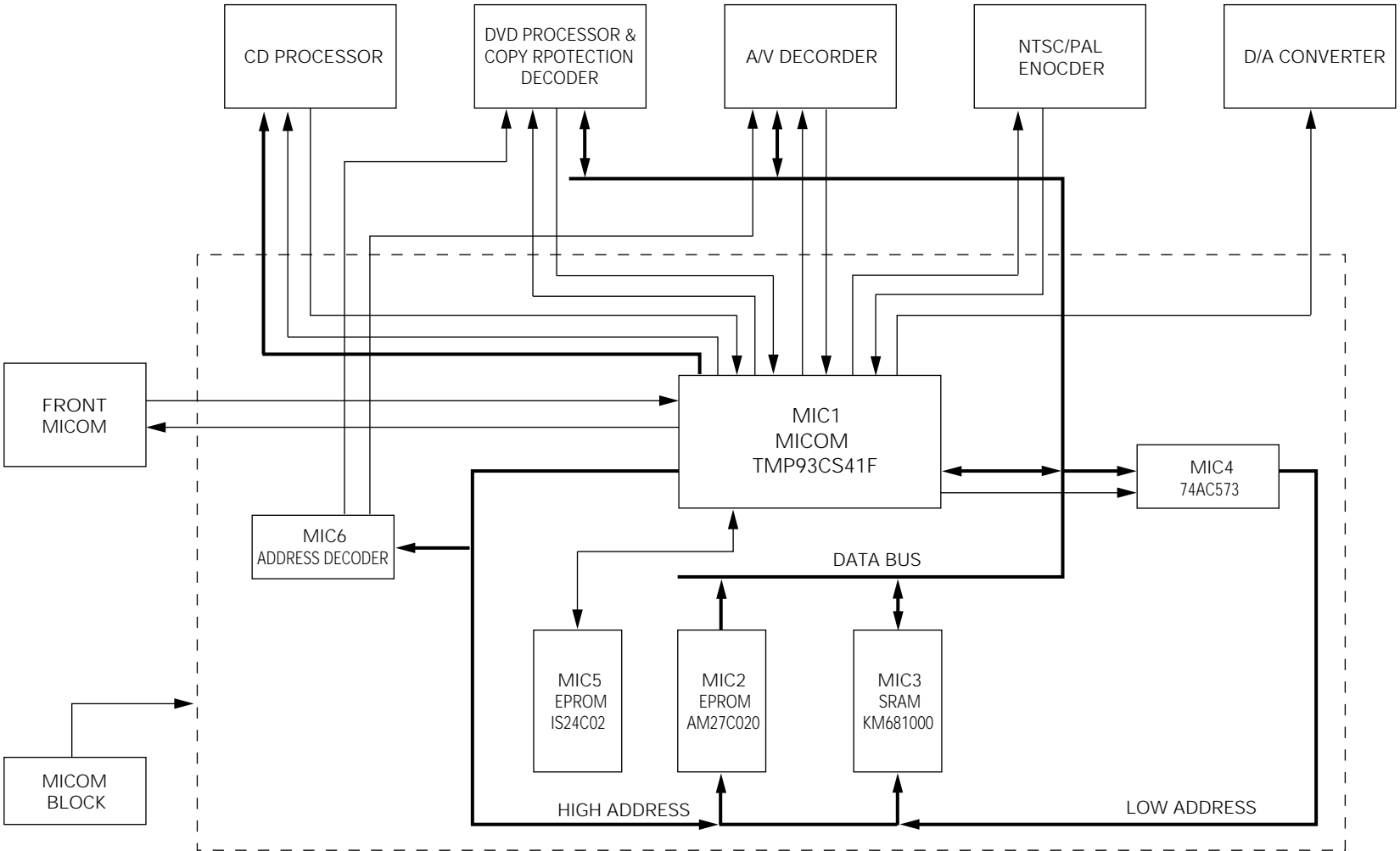

Fig. 2-22

### 2-3-3 Waveform description

The setup time is approx. 18 nsec. at falling edge of ALE(Address Latch Enable) signal, which has enough hold time.

At power of 5V, the min. setup time of MIC4(TC74AC573) is 5 nsec, and min. hold time is 3 nsec. It can be known that data input condition meets setup time and hold time. The eye part of input data in falling edge of ALE signal corresponds to address on the bus where address and data are mixed.

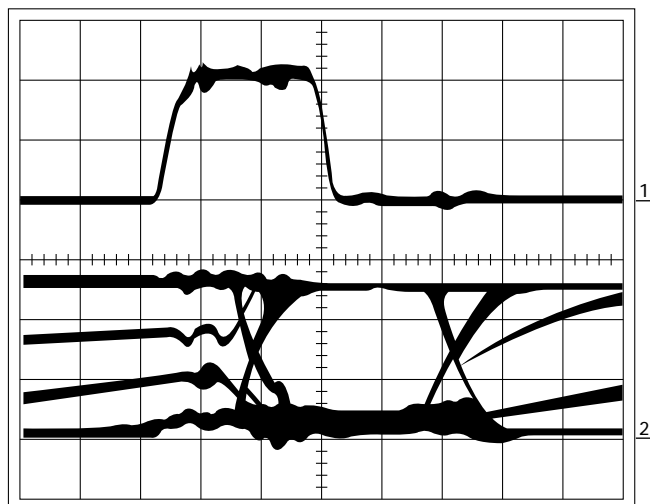

Fig. 2-23

- CH1 : ALE  
(MIC4-11, Address Latch Enable Signal)
- CH2 : HAD0-9  
(Input data of MIC4, Common bus data)

The inclining and rising part indicate floating range of data bus.

That is, there is no operational problem because micom is time area not to access any devices sharing a common bus. The waveform is shown to incline and rise by pull-up resistance and capacitance on PCB pattern.

When micom accesses each device sharing bus, it falls the chip select signal of corresponding chip to 0(Low) before trial. So to speak, the bus is used by time-division as shown in Fig 2-25, 26. Two and more devices can't be accessed simultaneously.

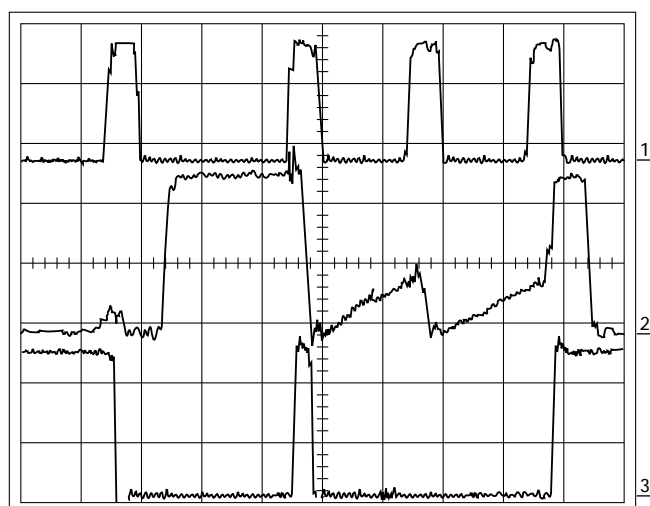

Fig. 2-24

- CH1 : ALE  
(MIC4-11, Address Latch Enable Signal)
- CH2 : HAD0-7 (MIC4-2 to 9, Input data)
- CH3 : HA0-7 (MIC4-19 to 12, Output data)

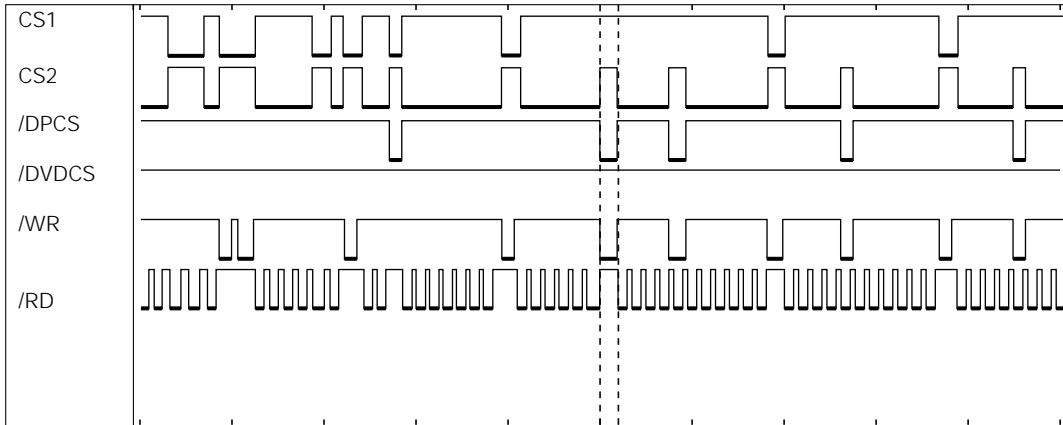

Fig. 2-25

- CH1 : CS1 (MIC3-22, SRAM CHIP SELECT)
- CH2 : CS2 (MIC2-22, EPROM CHIP SELECT)
- CH3 : DPCS (DIC6-76, COPY PROTECTION DECODER CHIP SELECT)
- CH4 : DVDCS (VIC1-175, A/V DECODER CHIP SELECT)
- CH5 : WR (MIC1-73, MICOM OUTPUT WRITE SIGNAL)
- CH6 : RD (MIC1-72, MICOM OUTPUT READ SIGNAL)

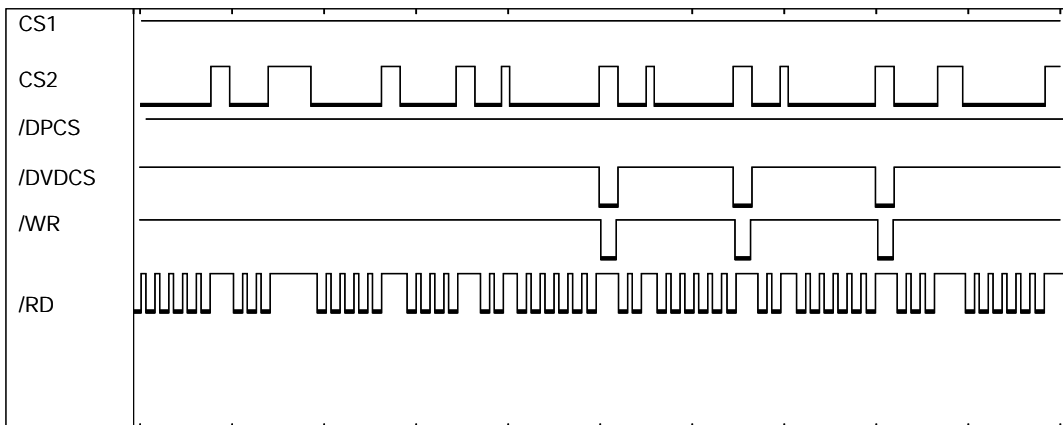

Fig. 2-26

- CH1 : CS1 (MIC3-22, SRAM CHIP SELECT)
- CH2 : CS2 (MIC2-22, EPROM CHIP SELECT)
- CH3 : DPCS (DIC6-76, COPY PROTECTION DECODER CHIP SELECT)
- CH4 : DVDCS (VIC1-175, A/V DECODER CHIP SELECT)
- CH5 : WR (MIC1-73, MICOM OUTPUT WRITE SIGNAL)
- CH6 : RD (MIC1-72, MICOM OUTPUT READ SIGNAL)

## 2-4 Signal control chip DIC1, DIC6 description

---

### 2-4-1 Outline

DIC1(TC90A19F) performs PLL(Phase Locked Loop), Sync detection, demodulation and error correction after converting RF signal inputted at DVD regeneration into digital data.

DIC6(TC6804F) receives signal-processed data in DIC1 and releases digital copy protection.

TC90A19F uses external memory(4M DRAM) as buffer as well as for error correction and carries out variable bit rate transfer function. VBR function uses the external buffer as buffer to absorb the difference of transfer rate occurring because the transfer rate of disk playback is faster than data transfer rate demanded by MPEG decoder(Video/ Audio Signal Process Chip).

In case of general disk refresh, the memory is almost filled up periodically. It is because Write rate to memory after disk playback and signal process is faster than Read rate of MPEG decoder. When the memory is filled, the fact is reported by interrupt to main micom, which controls the servo and kicks back the pick-up to the previous track after memorizing the last data read from disk until now. It takes some times to jump to the previous track and return to the original position(jump location) again. The full memory will have an empty space because MPEG decoder reads out data of memory.

When the memory has an empty space, where data can be processed and written and the pick-up correctly gets to the original location(kick back location) again, it reads data again and avoids the interrupt of data read previously.

The basic operation repeats to perform disk data read --> memory full --> move pick-up to previous track --> disk data read --> memory full --> move pick-up to previous track as described above.



### 2-4-3 Waveform description

It is used for internal digital signal process as 33MHz clock input waveform of DIC1 (TC90A19F) and carries out swing in 1.4V level on the basis of DC level 1.65V.

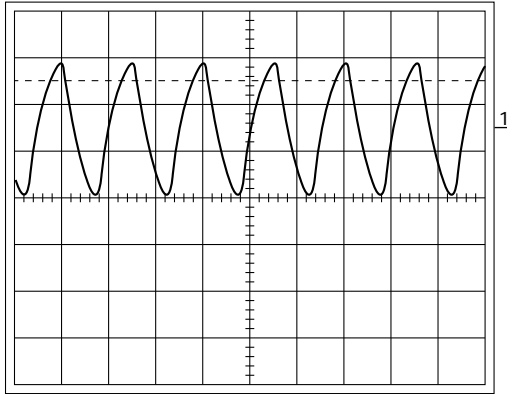

- CH1 : DPCK1(DIC1-3, 33MHz input clock)

Fig. 2-28

It is used for PLL and CLV control as 27MHz servo clock input and output waveform of DIC1. The input swings in approx. 2V of amplitude and the output swings in 3.3V.

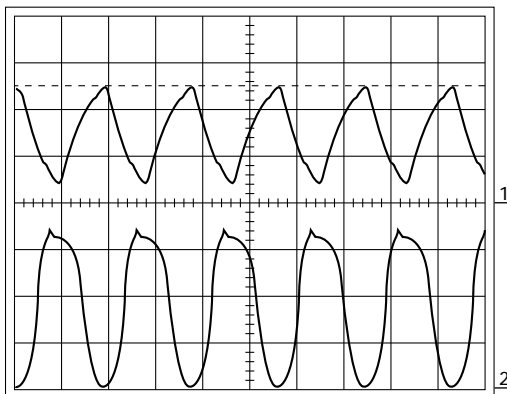

- CH1 : SVCKI (DIC1-5)
- CH2 : SVCKO (DIC1-6)

Fig. 2-29

CH1 is RF signal waveform inputted to DIC1 and inputted with 2.5V of amplitude on the basis of approx. 1.65V level. If RF signal is higher than slice level, CH2 of slice level is cut digital 1(HIGH) and if lower, digital 0(LOW) and converted into digital data. CH3 indicates a waveform that RF signal is cut by slice level and converted into digital data.

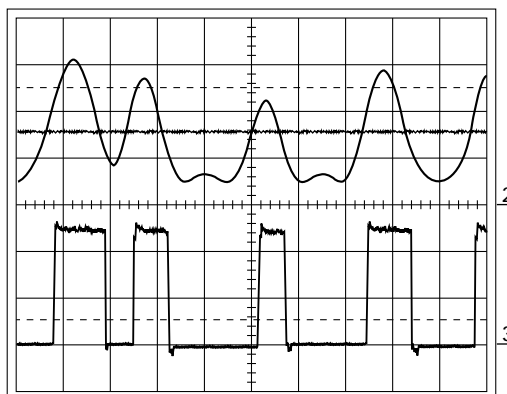

- CH1 : RFIN(DIC1-50, RF Input signal)
- CH2 : SLCO (DIC1-42, Slice level)
- CH3 : ED7 (DIC1-34, Sliced data of RF signal)

Fig. 2-30

CH1 is RF signal waveform at refresh the error area of disk. It shows RF waveform swing lower than slice level. At the end, this part is displayed as error which is recovered to the original data by error correction signal of DIC1.

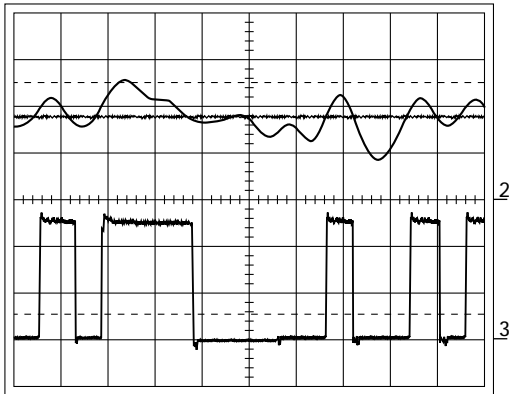

- CH1 : RFIN(at refreshing small error area of disk)
- CH2 : SLCO (Slice level)
- CH3 : ED7 (Sliced and outputted data of RF signal)

Fig. 2-31

It shows error signal output, comparing PLL clock and phase difference in DIC1 when RF signal is inputted. The phase difference signals is inputted into VCO after summing in external PLL circuit of DIC1. VCO changes PLL clock frequency according to input voltage. The middle frequency of external PLL circuit is approx. 27MHz and a clock(DIC1-26) swung by PLL on the basis of 27MHz may be shown at DVD refresh.

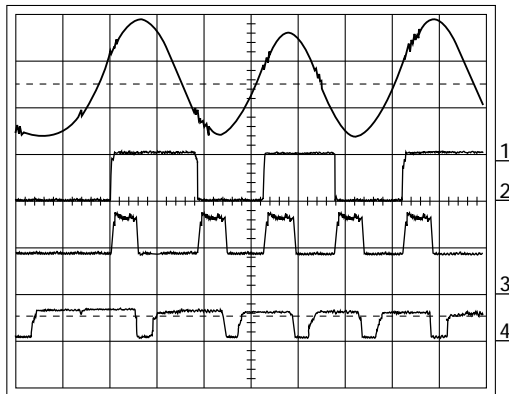

- CH1 : RFIN(DIC1-50, RF Input signal)
- CH2 : SLCO (DIC1-34, Sliced data)
- CH3 : PDON (DIC1-36, Phase difference signal)
- CH4 : PDOP (DIC1-37, Phase difference signal)

Fig.2-32

PLL lock at DVD playback

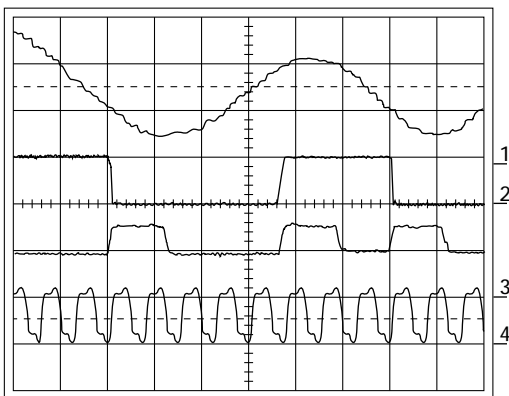

- CH1 : RFIN(DIC1-50, RF Input signal)
- CH2 : SLCO (DIC1-34, Sliced data)
- CH3 : PDON (DIC1-36, Phase difference signal)
- CH4 : PLCK (DIC1-26, PLL clock)

Fig. 2-33

It shows PLL clock swung on the right and left on the basis of input RF signal, PLL clock and trigger at DVD playback. The eye of RF signal is open in PLL lock state.

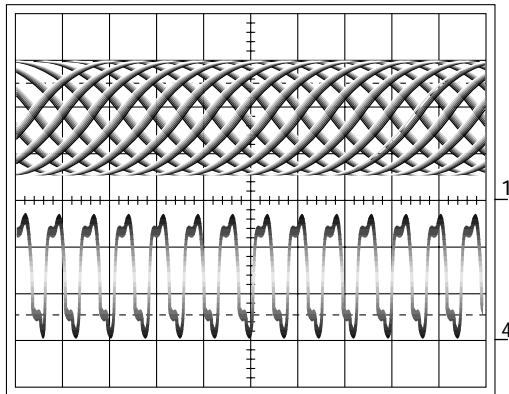

Fig. 2-34

- CH1 : RFIN(DIC1-50, RF Input signal)  
( $V_{p-p}$  is approx. 2.5V)
- CH4 : PLCK (DIC1-26, PLL clock)

It shows RF signal and RLLD signal waveform at DVD refresh and RLLD waveform is regular as 1.65V. If a serious error occurs in disk, RLLD signal is outputted as correction signal and enters PLL control system after summing with phase difference signal.

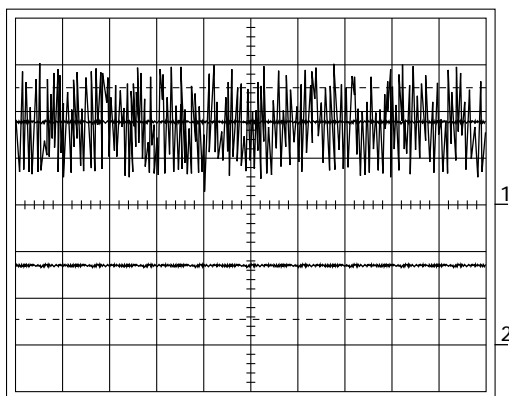

Fig. 2-35

- CH1 : RFIN(DIC1-50, RF Input signal)
- CH2 : RLLD (DIC1-38, RLLD signal at disk refresh)

RLLD signal is outputted at disk halt or occurrence of serious error.

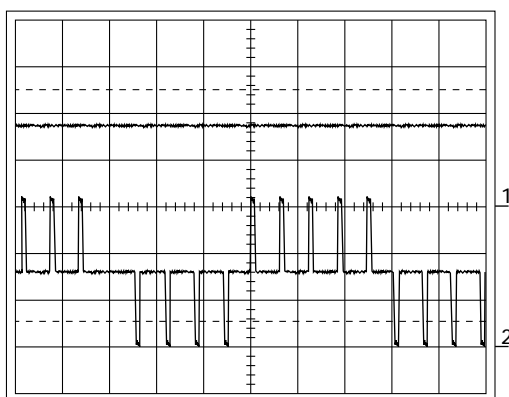

Fig. 2-36

- CH1 : RFIN(DIC1-50, RF Input signal)
- CH2 : RLLD (DIC1-38, RLLD at disk halt or occurrence of serious error)



Because RF signal, external VCO input voltage and VCO control voltage swings terribly at disk halt, PLL output clock changes largely.(PLL not unlock state)

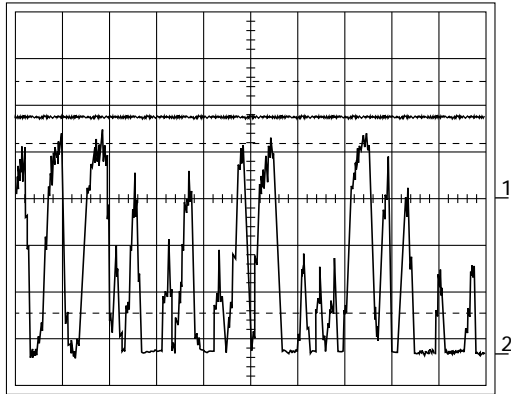

Fig. 2-37

- CH1 : RFIN(DIC1-50, RF Input signal at disk halt)
- CH2 : VCO control signal (DD1-3, Variable capacitance diode)

The input voltage of VCO becomes a regular voltage level(approx. 3.59V in Figure) at DVD playback and VCO outputs PLL clock depending on this control voltage. The input voltage of VCO swings a little and appears as frequency variation of VCO as much as change amount. As the control voltage of VCO is higher, PLL clock frequency becomes high.

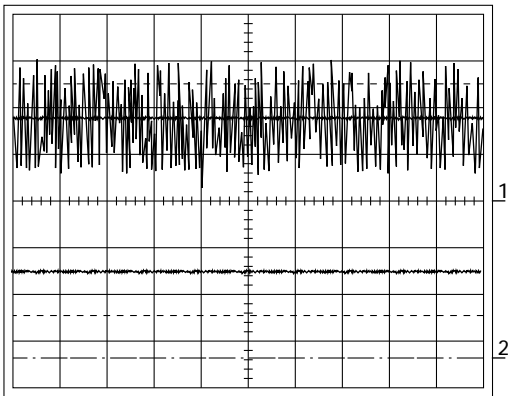

Fig. 2-38

- CH1 : RFIN(DIC1-50, RF Input signal at disk playback)
- CH2 : VCO control signal (DD1-3, Variable capacitance diode)

When the inputted RF signal is error-correction processed in DIC1 and inputted into DIC6, it is processed to release the digital copy protection. The digital copy protection released data makes the acknowledge signal of CH2 LOW and outputs data(CH4)

when MPEG decoder(Video, Audio signal process chip) falls the request signal to 0(LOW) and demands data. The data acknowledge signal of CH2 and data of CH4 are synchronized with BSTCLK(CH3) and outputted. BSTCLK of CH3 is made by division of 27MHz into 16.

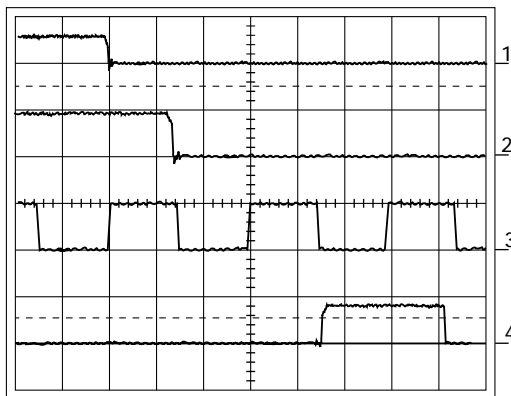

Fig. 2-39

- CH1 : PVSREQ (DIC6-13, Data request signal from DVD1)
- CH2 : PVSACK (DIC6-14, Output data acknowledge signal)
- CH3 : BSTCLK (DIC6-17, Output clock)
- CH4 : PVSIN (DIC6-5 to 11, Output data)

DIC6 shares the data bus of micom with other devices(DVD1, EPROM, SRAM). CH2 shows the measurement of a signal line of data bus. The inclining and rising part in CH2 indicates high impedance state after data bus floating. The data bus is pulled up by 4.7K resistance.

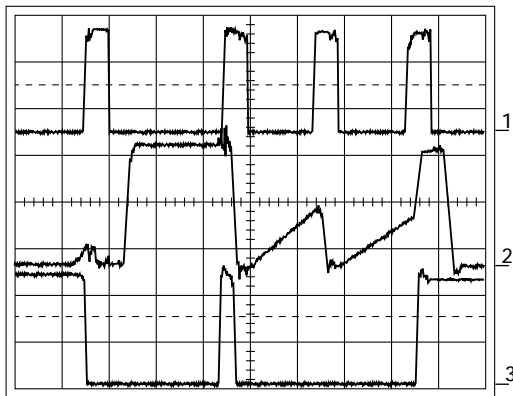

Fig. 2-40

- CH1 : ALE (MIC4-11, Address latch enable signal)
- CH2 : HAD0-7 (MIC402 to 9, Main micom address and data multiplexed bus)
- CH3 : HA0-7 (MIC4-19 to 12, Main micom address 0-7)

It shows access in fast page mode as waveform when DIC1 accesses external memory(4Mbit DRAM) at DVD refresh.

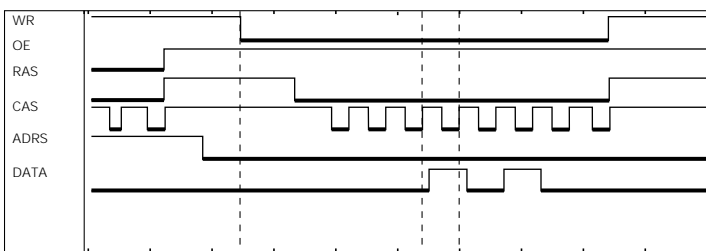

Fig. 2-41

- WE : Write enable(DIC2-7)
- OE : OUTPUT ENABLE (DIC2-22)
- RAS : RAW ADDRESS STROBE (DIC2-8)
- CAS : COLUMN ADDRESS STROBE (DIC2-23)
- ADRS : ADDRESS
- DATA : DATA

It shows the external memory refresh of DIC1 and uses Cas Before Ras Refresh.

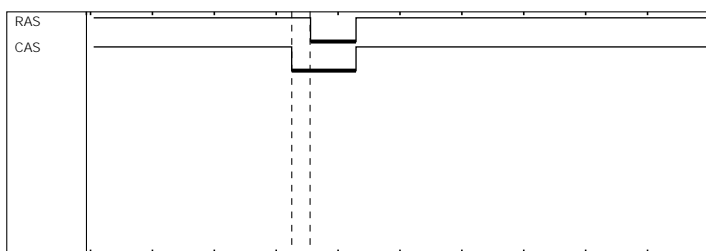

Fig. 2-42

- DIC2 (4MDRAM) REFRESH TIME

It shows refresh per approx. 31 usec as measurement of refresh waverform outputted by DIC1 in large timing.

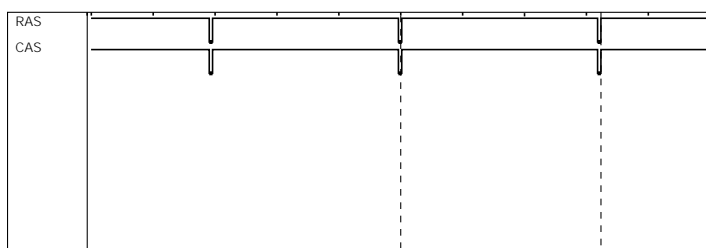
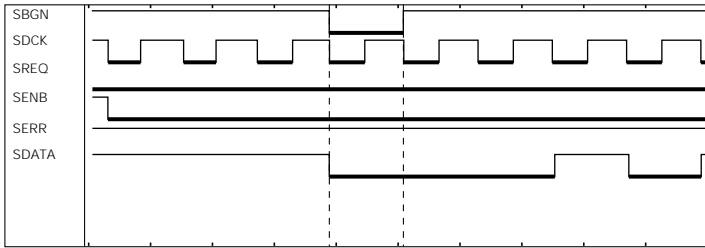

Fig. 2-43

Refresh time(PERIOD) of DIC2(4MDRAM)

It measures the timing that data processed in DIC1 at DVD playback enters DIC6



- CH1 : SBGN (DIC1-92, SECTOR BEGIN)
- CH2 : SDCK (DIC1-94, CLOCK)
- CH3 : SREQ (DIC1-96, DATA REQUEST)
- CH4 : SERR (DIC1-91, DATA ERROR)
- CH5 : SDATA (DIC1-81~84, 87~90, DATA)

Fig. 2-44

It shows the timing of control signal, address and data bus when micom accesses DIC1 and DIC6. So to speak, timing at writing a value in the internal register of DIC1 and DIC6.

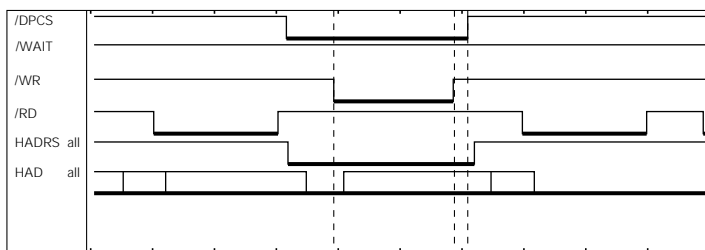

- CH1 : DPCS (DIC6-76, TC90A19/TC6804F chip select)
- CH2 : /WAIT
- CH3 : WR (DIC6-78, TC90A19F/TC6804F register write)
- CH4 : RD (DIC6-77, TC90A19F/TC6804F register read)
- CH5 : HADRS (DIC6-74, 75, Micom address bus)
- CH6 : HAD (DIC6-65 to 72, Micom data bus)

Fig. 2-45

It shows a waveform that DIC1 requests a management to micom by interrupt generation. Micom recognizes the interrupt and writes a value in register of DIC1 to respond (instruction) for interrupt. Micom accesses DIC1 five times in Figure. Micom recognizes the operation of chip and makes a necessary instruction after receiving the interrupt generated in DIC1 and DIC6 and accessing the corresponding chip. The instruction is executed by accessing the corresponding chip and writing a value(digital) into register. Micom accesses DIC1 via DIC6. The block diagram shows that the same type as signal line connecting DIC6 and micom is composed between DIC1 and DIC6. That is, DIC1 is interfaced with micom through DIC6.

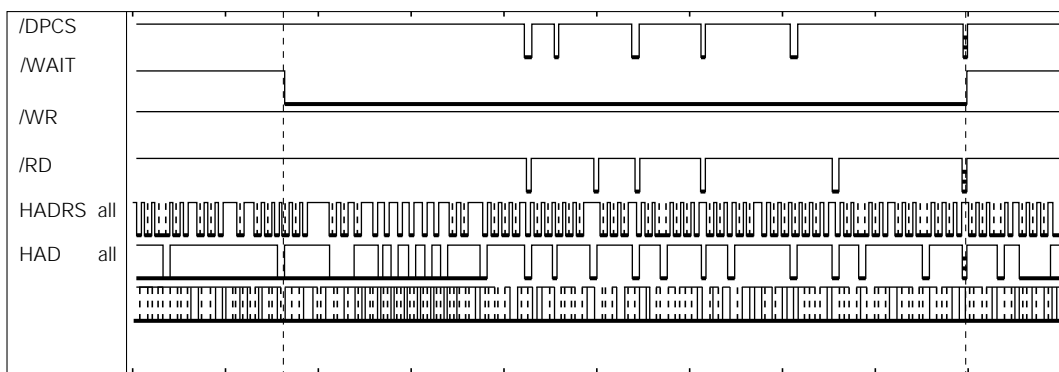

Fig. 2-46

- CH1 : DPCS (DIC6-76, TC90A19/TC6804F chip select)
- CH2 : DPRINT (DIC1-23, DIC6-80, TC90A19F/TC6804F interface)
- CH3 : WR (DIC6-78, TC90A19F/TC6804F register write)
- CH4 : RD (DIC6-77, TC90A19F/TC6804F register read)
- CH5 : HADRS (DIC6-74, 75, Micom address bus)
- CH6 : HAD (DIC6-65 to 72, Micom data bus)

## 2-5 SERVO circuit

---

### 2-5-1 Outline

SERVO system of DVD is divided into Focusing SERVO, Tracking SERVO, SLED Linked SERVO and CLV SERVO(DISC Motor Control SERVO).

1. Focusing SERVO

Focuses the optical spot output from object lens onto the disc surface. Maintains a uniform distance between object lens of Pick-up and disc (for surface vibration of disc).

2. Tracking SERVO

Make the object lens follow the disc track in use of tracking error signal (created from Pick-up).

3. SLED Linked SERVO

When the tracking actuator inclines outwardly as the object lens follows the track during play, the SLED motor moves slightly (and counteracts the incline).

4. CLV SERVO (DISC Motor Control SERVO)

Controls the disc motor to maintain a constant linear velocity (necessary for RF signal).

### 2-5-2 SERVO system block diagram

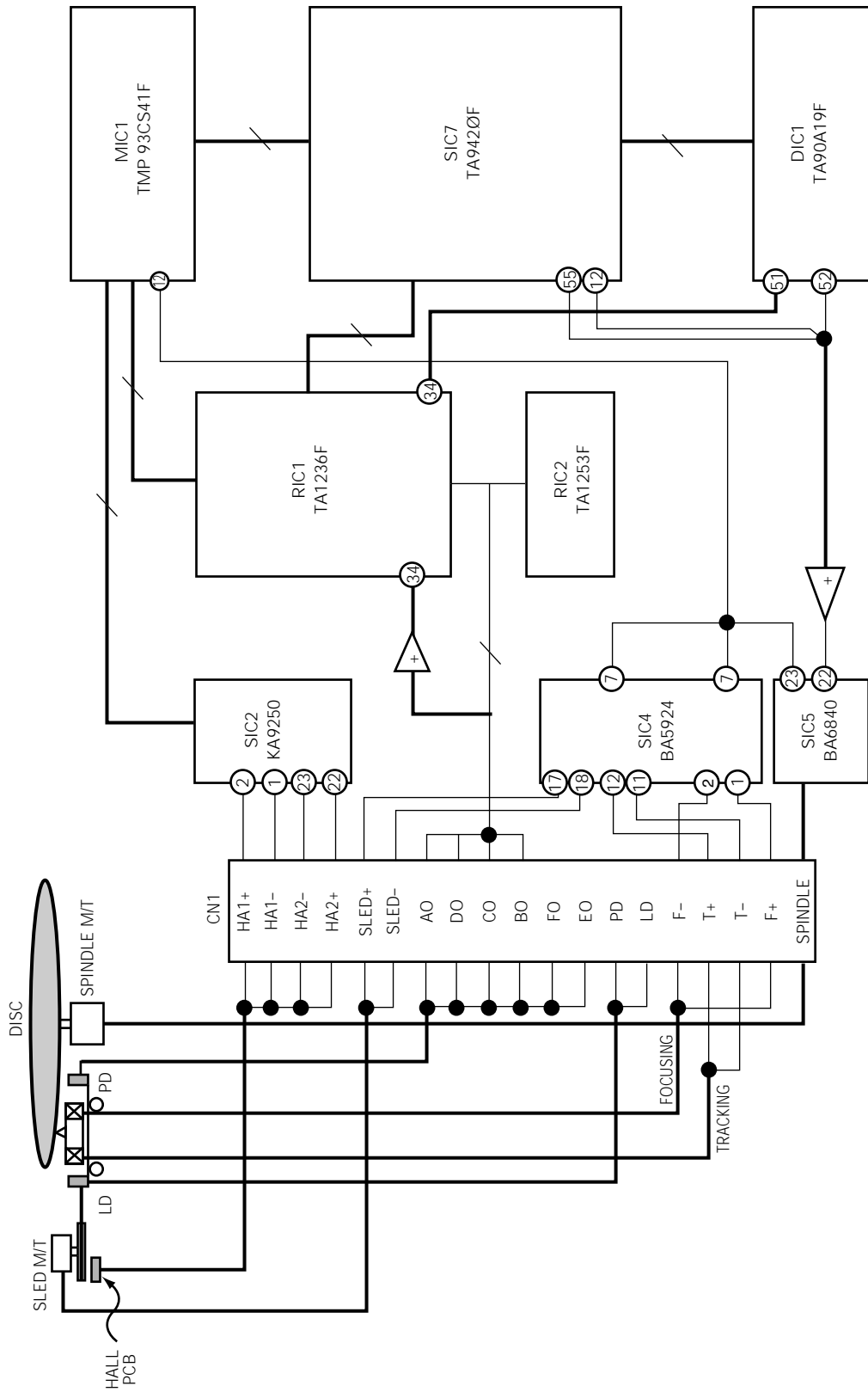

Fig. 2-47

## 2-5-3 Operation

### 2-5-3(a) FOCUSING SERVO

#### 1. Focus input

The focus loop is changed from open loop to closed loop, and the triangular waveform moves the object lens up and down (at pin 48 of SIC7 during Focus SERVO ON.) At that time, S curve is input to pin 43 of SIC7.

SBAD (pin 44 of SIC7) signal, summing signal of PD 1, B, C, D, is generated by S curve, and zero cross(2.1V) point occurs when S curve is focused and SBAD signal exceeds a preset, constant value. The focus loop is changed to closed loop, and the object lens follows the disc movement, maintaining a constant distance from the disc.

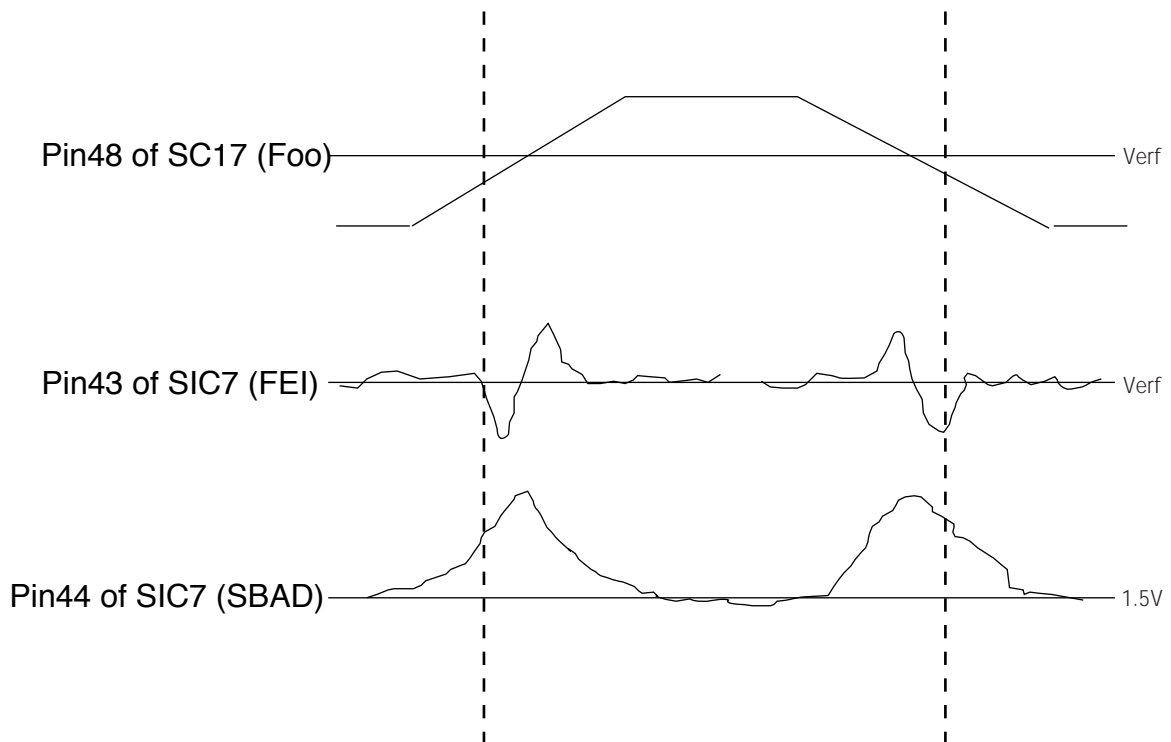

(these operations are same in CD and DVD).

Fig. 2-48

#### 2. Play

When focus loop closes the loop during focus servo on, both pin 43 and pin 48 of SIC7 are controlled by VREF voltage (approx. 2.1V), and pin 1, 2 of SIC4 are approximately 4.5V.

### 2-5-3(b) TRACKING SERVO

#### 1. Normal play mode

##### 1) For DVD

Composite : The signal output from PD A, B, C, D of Pick-up, the tracking error signal (RIC2 pin 14) uses the phase difference of A+C and B+D in RIC2, and inputs to terminal 8 of RIC1. The signal is output to RIC1 pin 21, and input to SIC7 pin46(TEI). Then, it is output to SIC7 pin 49 via digital equalizer, and applied to the tracking actuator through SIC4. Pins 46, 49 of SIC7 are controlled by VREF (approx. 2.1V) during normal play.

Meanwhile, DVD repeats the track jump from 1 to 4 in inner direction at normal play ( because data- read speed from disc is faster than data output speed on screen).

2) For CD, VCD

Receive the signal output through E, F of Pick-up, from RIC1, differently from DVD and make the tracking error signal through RIC1 pin21. The tracking error signal is similar to DVD.

2. SEARCH Mode :

Search mode : Fine seek,(Moving the tracking actuator slightly little below 255 track) and coarse search, moving much in use of sled motor. The coarse search will be described in sled linked servo and now, the fine seek is explained shortly.

If the object lens is located near target, cut off the tracking loop and give the control signal as many as desired count to move the tracking actuator via SIC7 pin 49 terminal(TRO).

2-5-3(c) SLED LINKED SERVO

1. Normal play mode

Move SLED motor slightly by means of PWM signal in SIC7 pin 54, as the tracking actuator moves along with track during play. Control to move the entire Pick-up as the tracking actuator moves.

2. Coarse search mode

In case of long-distance search(such as chapter search), pin 48 uses sled FG (SIC2 pin 19, which is generated) by rotation of sled motor via hall PCB. Then, read ID and compute the existing track count after input of next track. If the existing track count is within fine seek range, tracking begins using fine seek.

2-5-3(d) CLV SERVO(DISC MOTOR CONTROL SERVO)

1. For DVD mode

Input RF signal (from Pick-up) to DIC1 pin50. Detect SYNC signal from RF in DIC1, and output PWM signal to DIC1 pin 54 for constant linear velocity.

2. For DC, VCD mode

Input RF signal (from Pick-up) to SIC7 pin 36, Detect SYNC signal from RF in SIC7, and output PWM signal to SIC7 pin 55 for constant linear velocity.

## 2-6 A/V decoder and output circuit description

### 2-6-1 Outline

VIC1(A/V decoder, CL61209P) transfers video data to VIC3(PAL/NTSC digital encoder, STV0119) and audio data to AIC3(PCM1720), AIC9(PCM1720), AIC14(PCM1723), KIC3(PCM1710, Audio D/A converter) after receiving and decoding A/V signal compressed from DIC6(Digital copy guard, TC6804AF) and SIC7(Servo processor, TC9420). VIC31 performs RGB encoding, copy guard processing and D/A conversion for the inputted signal and the converted analog video signal is outputted to exterior via amplifier, low pass filter and buffer of back analog part. The audio signal is D/A converted via AIC3, AIC9, AIC14 and KIC14, too and outputted to exterior through analog signal process similar to video signal.

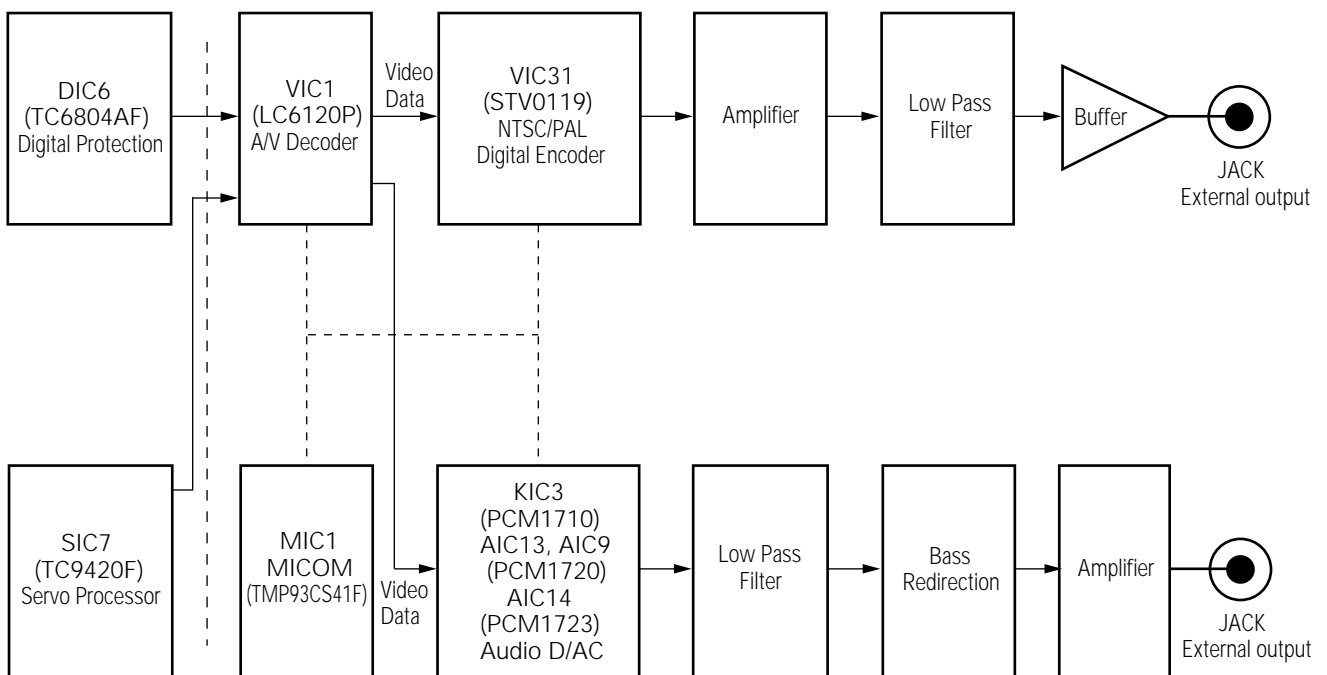

Fig. 2-49 A/V decoder and output block diagram



1. A/V decoder VIC1(CL6120P)

VIC1 receives DVD data compressed from DIC6(Digital protection GA) and VCD and CD data compressed from SIC7(Servo processor) for decoding. VIC8 and VIC9(74HC157, Digital mux.) are used to select one out of two types of signals and the control signal is DVD\_SEL signal inputted from pin 83 of main micom. DRAM(VIC3, 4, 5, 6, 7 ; KM416C254DJ-6) of 20Mbytes is used for decoding data storage and EPROM(VIC2 : AM27C4096-120) of 4Mbytes is used to save the decoding program. The signals of PVSREQ, BSTCLK, PLRERR, PVSACK, etc. indicate a decoding state during DVD refresh and help a smooth decoding for communication with DIC6.

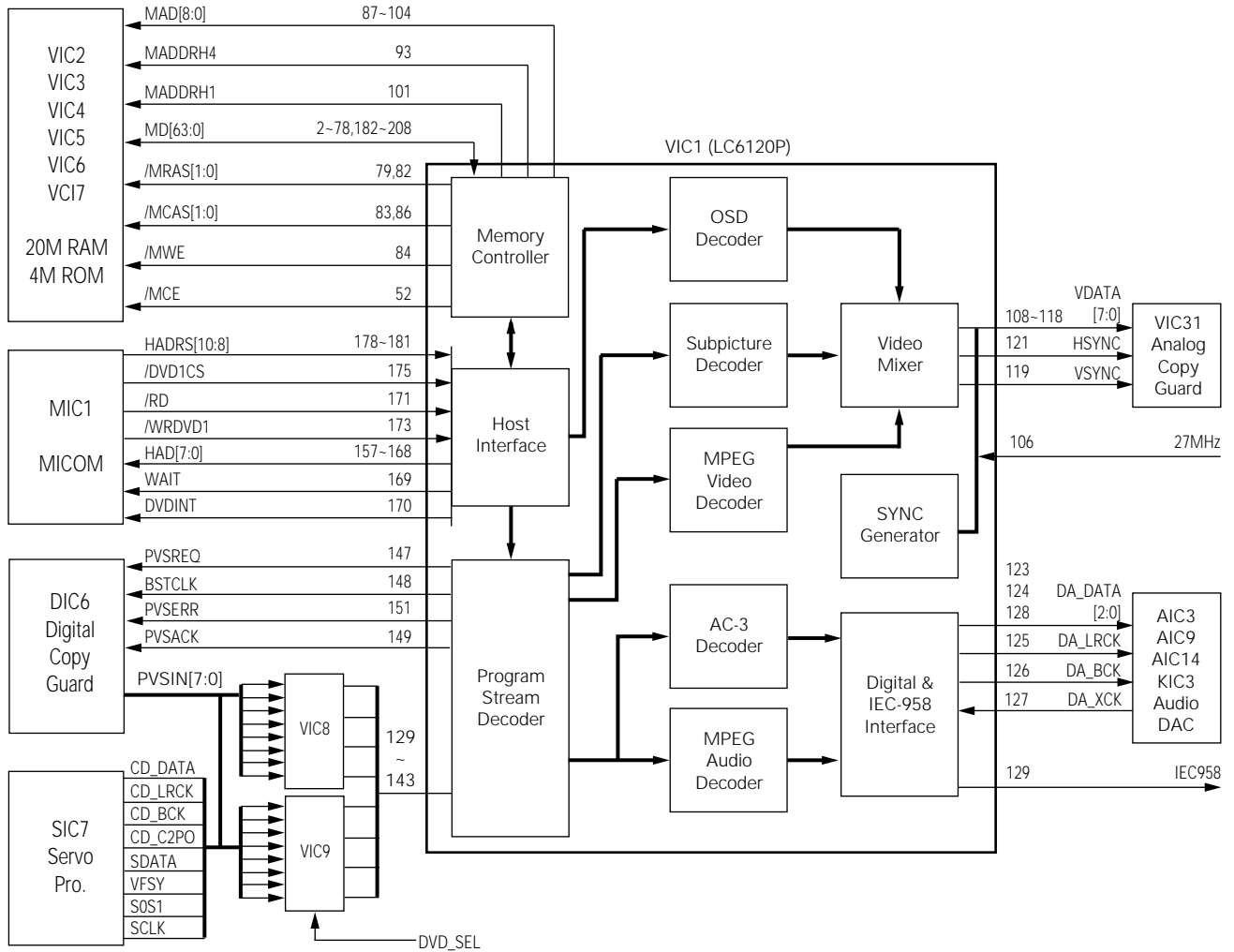

Fig. 2-50 A/V decoder VIC1(LC6120P) signal

## 2. NTSC/PAL digital encoder(STV0119)

A/V decoder receives 8 bit digital video signal(VDATA[7..0]) of ITU-R656 format, HSYMC and VSYNC from VIC1(CL6120P). When CR/CB/Y signal muxed ITU-R656 format is inputted, first demuxing is performed to release the format. The demuxed signal obtains each RGB/Y/C signal via RGB encoding, uminance processing and chroma processing. At that time, a signal transformation and addition are made by copy guard processing and obstruct the normal signal copy.

The composite signal is formed by addition of luminance and chrominance signal among them. The above signals select RGB or Y/C/CVBS by means of switch and are outputted out of chip through DAC.

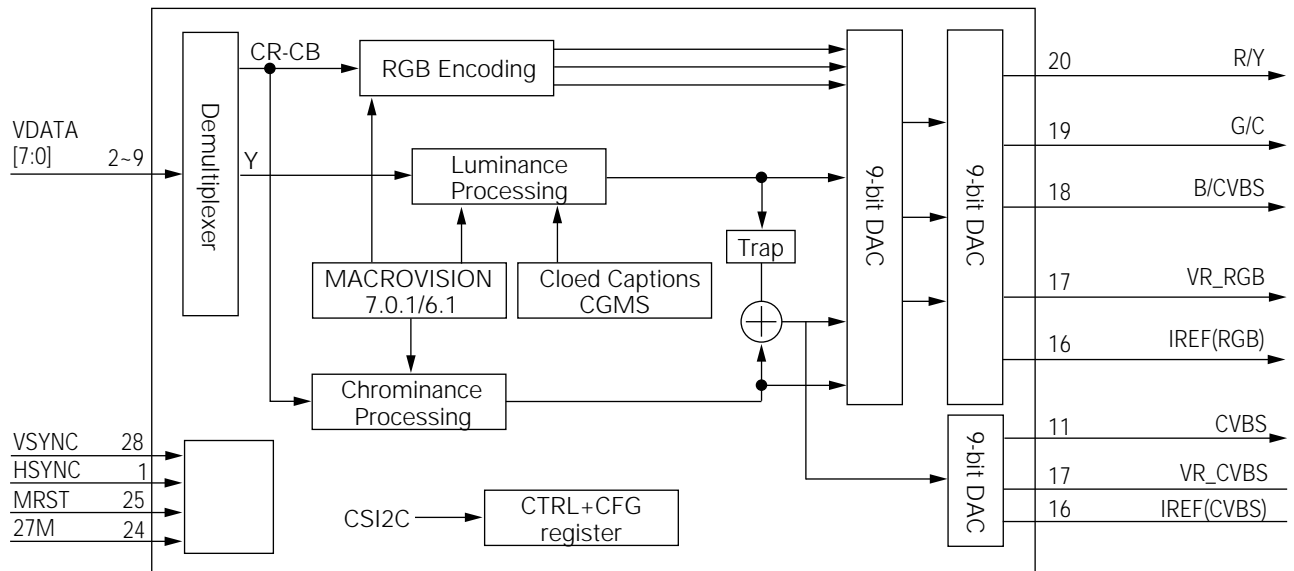

Fig. 2-51 VIC3(STV0119) internal block diagram

## 3. Amplifier

VQ2, VQ8, VQ14 and VQ18 peripheral circuits are amplifier parts to set the video signal outputted from STV0119 to rated output level. VR57 is load resistance demanded by STV0119 and the gain is determined by resistance ratio interfaced with collector and emitted of each transistor.

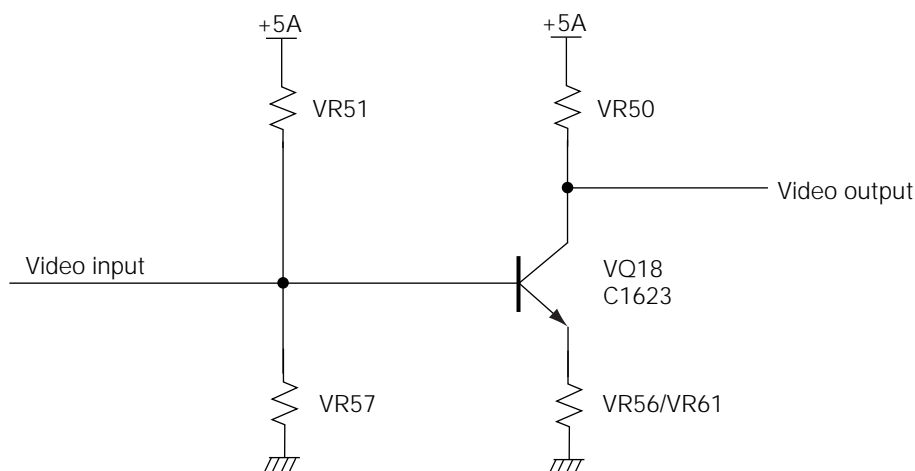

Fig. 2-52

#### 4. Low pass filter VFLT2, VFLT4

VFLT2 and VFLT4 remove quantization noise occurring in the course of D/A conversion as low pass filter with cut-off frequency of 6.75MHz.

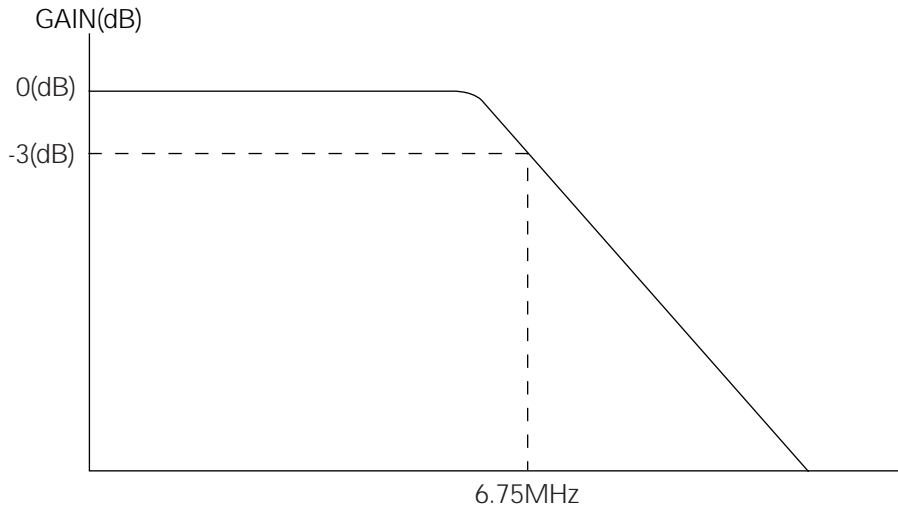

Fig. 2-53 Frequency features of VFLT2/VFLT4

#### 5. Switch

This system selects and outputs RGB or Y/C by register setting of STV0119. If Y/C is selected, Y/C signal is outputted to Y/C jack and RGB jack. These signals are abnormal and had better not to be outputted, seeing in RGB jack. It is same at RGB output. So, analog switch VIC32(14053) is used.

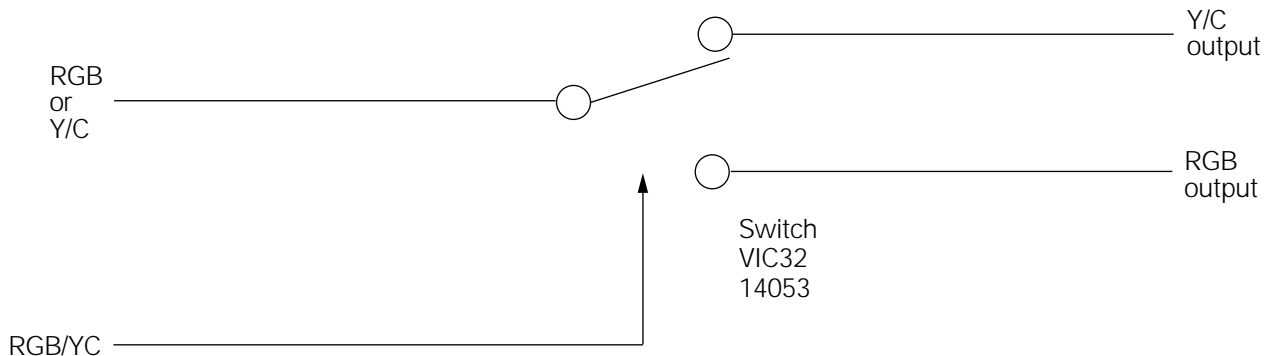

Fig. 2-54 RGB, Y/C switching

## 2-7 Audio circuit description

### 2-7-1 Outline

The audio data transmitted from A/V decoder(VIC1:LC6120P) are converted into analog signal via audio D/A converter and outputted through power filter and amplifier. DVD audio is outputted after division into two cases that only 2 channels(L/R channel) are used and 5.1 channel of AC3 is used. CD and VCD are outputted with only 2 outputs(L/R channel).

If DVD of 2 channels is used, rear L/R channel, center channel and subwoofer channel are mixed and outputted in 2 channels. CD and VCD are outputted only in 2 channels in stereo.

The digital signals(IEC-958 Output) outputted from A/V decoder are outputted to digital amp and AC-3 amp through optical jack(opt) and RCA jack(RC45).

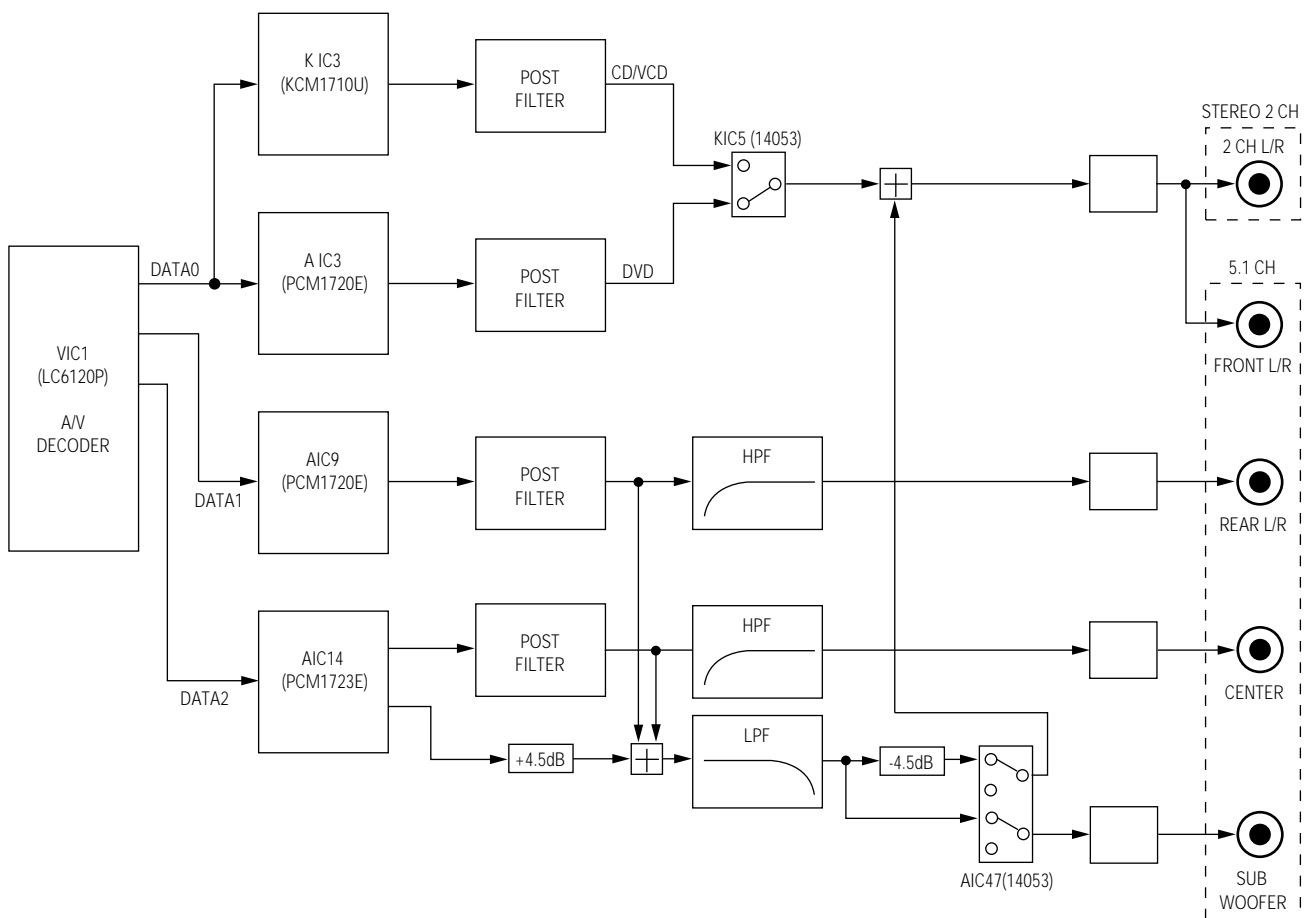

Fig. 2-55 Audio output block diagram

## 2-7-2 DVD audio output

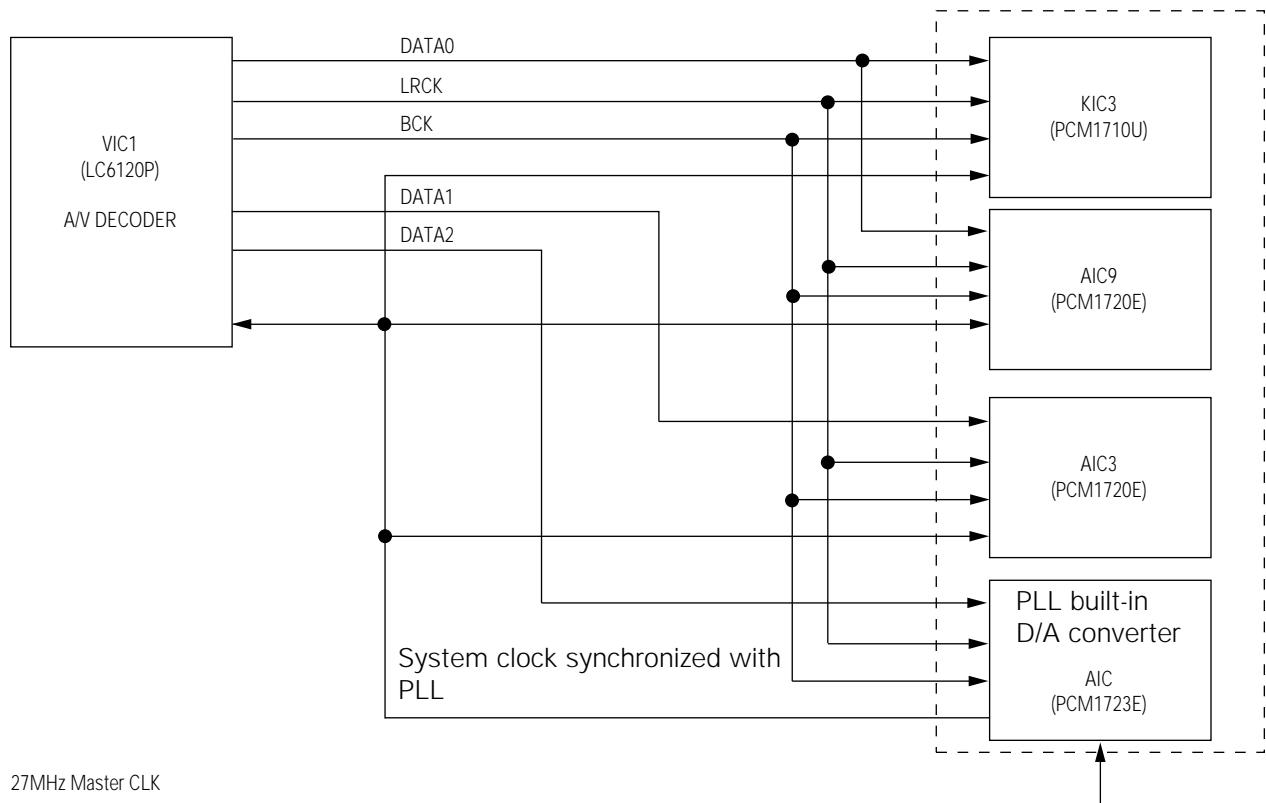

Fig. 2-56 Audio data and CLK

### 1. AC-3 5.1 channel

The system CLK generated by AIC14 built-in PLL circuit is provided for A/V decoder and audio D/A converter and Sync. of each channel is agreed.

DVD audio data outputted from VIC1 A/V decoder are supplied to DATA0 for 2 channels and to DATA0-2 for 5.1 channel. Then, LRCK is outputted by 48KHz or 96KHz.

Front L/R channel is outputted in DATA0, rear L/R channel in DATA1 and center and sub woofer channel in DATA2. DATA0 data are outputted to front L/R channel after D/A conversion and filtering of AIC3(PCM1720E).

DATA1 data are outputted by analog signal of D/A converter of AIC9 and to rear L/R via HPF after filtering.

DATA2 data are converted into analog signal by D/A converter of AIC14 and to rear L/R via HPF after filtering and a channel is outputted by center signal via post filter nad HPF.

The other channel of AIC14 is outputted by subwoofer signal through amplifier of +4.5dB and LPF.

### 2. Bass redirection(2 Channel down mixing)

If only 2 speakers are used in spite of output to 5.1 channel, center/rear and subwoofer signal may be down mixed in 2 channel L/R.

If there is a subwoofer speaker, it is outputted directly to subwoofer without down mixing.

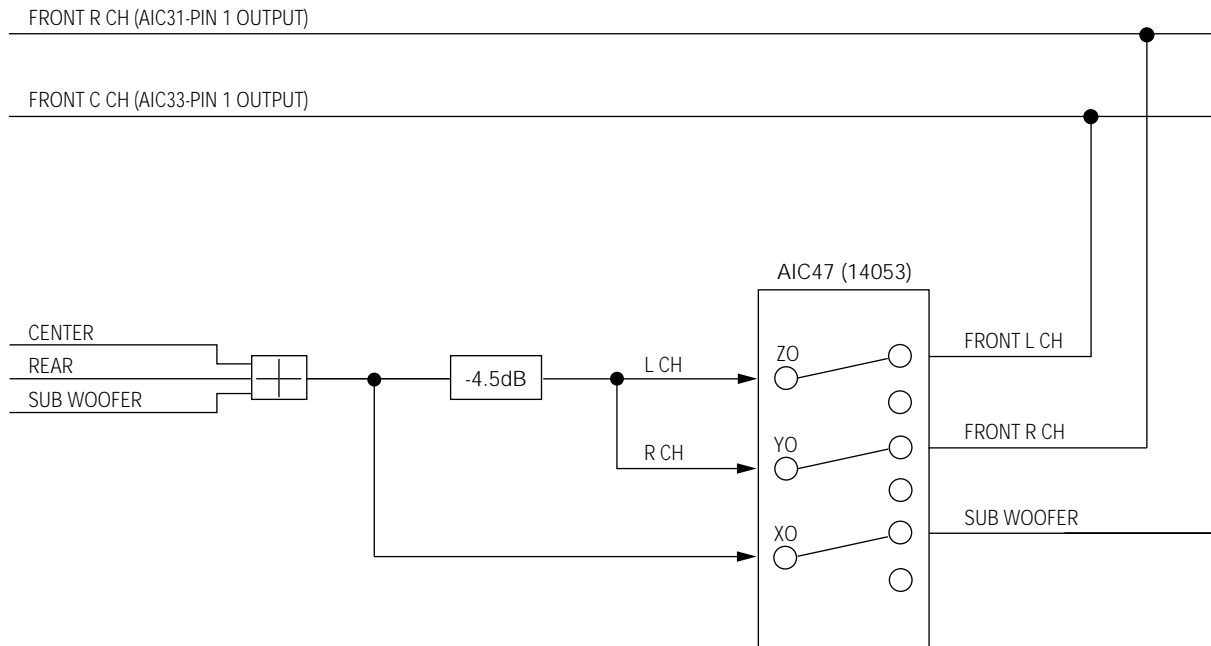

Fig. 2-57 2 Channel down mixing

The switch operations are carried out by AIC47(14053) in case of 2 Channel down mixing and sub woofer speaker using.

	CD/VCD	DVD	
		Down mixing	Sub woofer speaker using
AIC47(9,10,11 pin)	L	H	L
Output	AIC17-2, 5 pin No down mixing:open	AIC17-1, 2 pin Mixed L/R output	AIC17-12 Sub woofer speaker output

Table 2-1 Down mixing output table

### 2-7-3 CD/VCD audio output

The audio of CD and VIDEO-CD bypasses the audio data of SIC7(TC9420F) in VIC1 A/A decoder and outputs them to DATA0. Also, they are outputted in stereo 2 channel(L/R channel) via D/A conversion and filtering of KIC3. Then, the switching of DVD audio output outputted from AIC3 and CD/VCD audio output of KIC3 at output in stereo 2 channels is describes in the below table.

	CD/VCD	DVD
KIC5-9, 10 pin (A,B)	H	L
Output	KIC5-1, 13 Pin signal output	KIC5-2, 12 Pin signal output

Table 2-2 CD/DVD Output table

## 2-8 IC Blocks

### 2-8-1 DIC1 (TC90A19F)

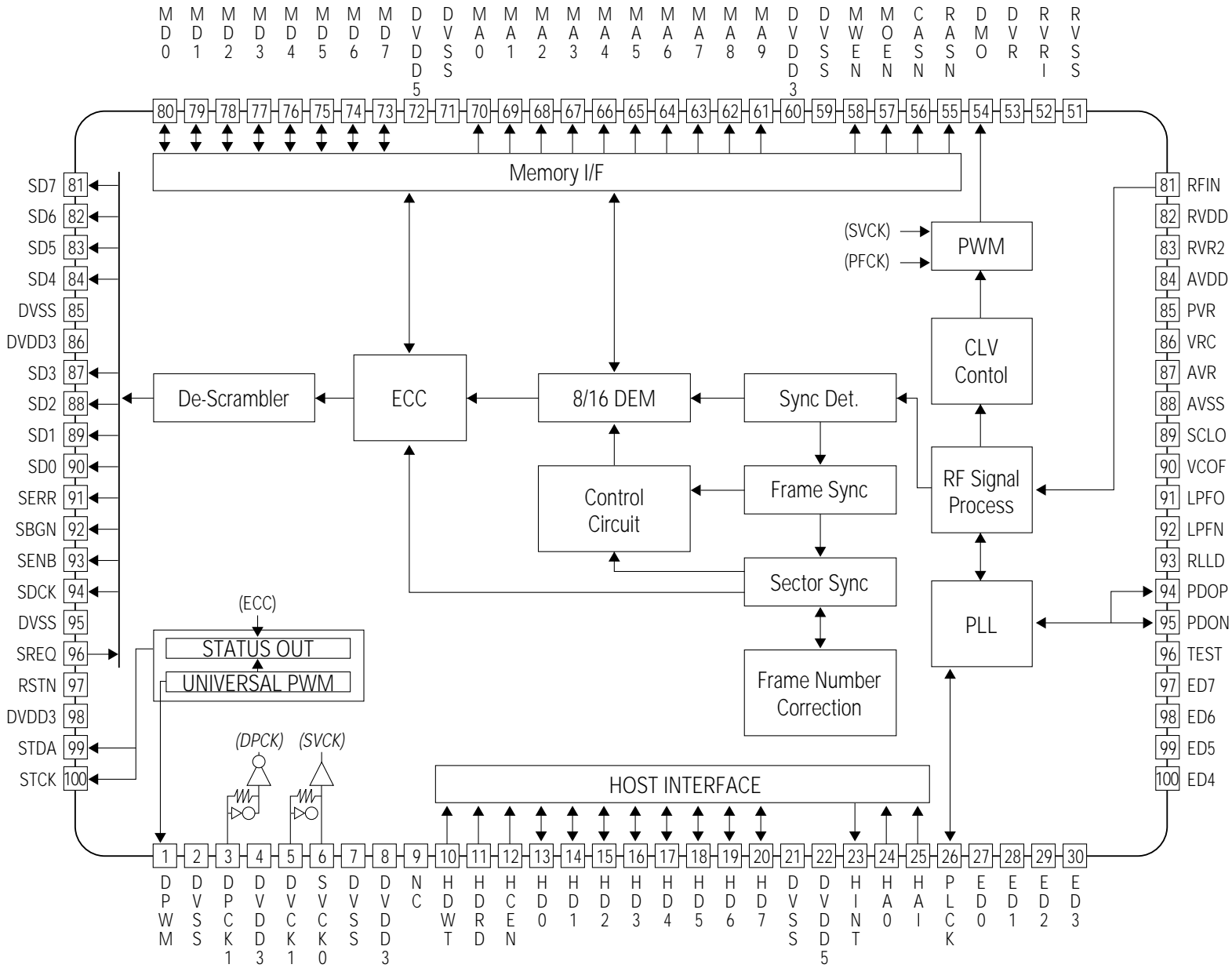





### 2-8-4 AIC3/AIC9 (PCM1720)

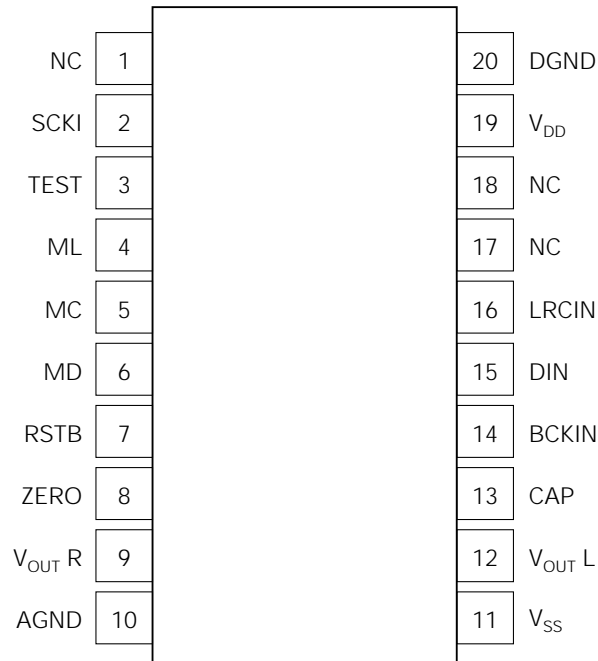

### 2-8-5 AIC14 (PCM1723)

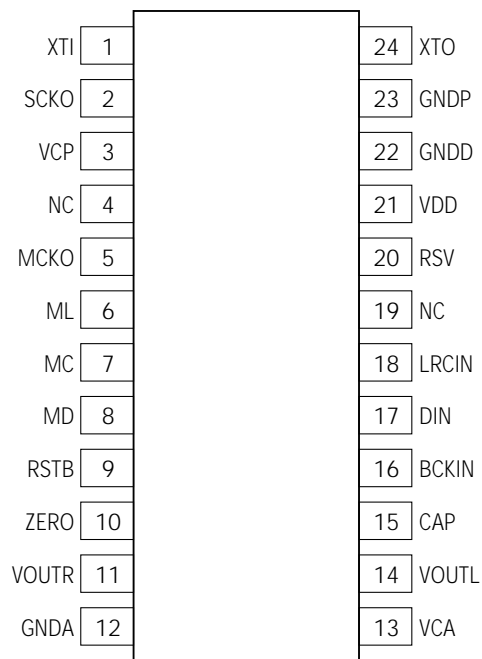

### 2-8-6 RIC1 (TA1236F)

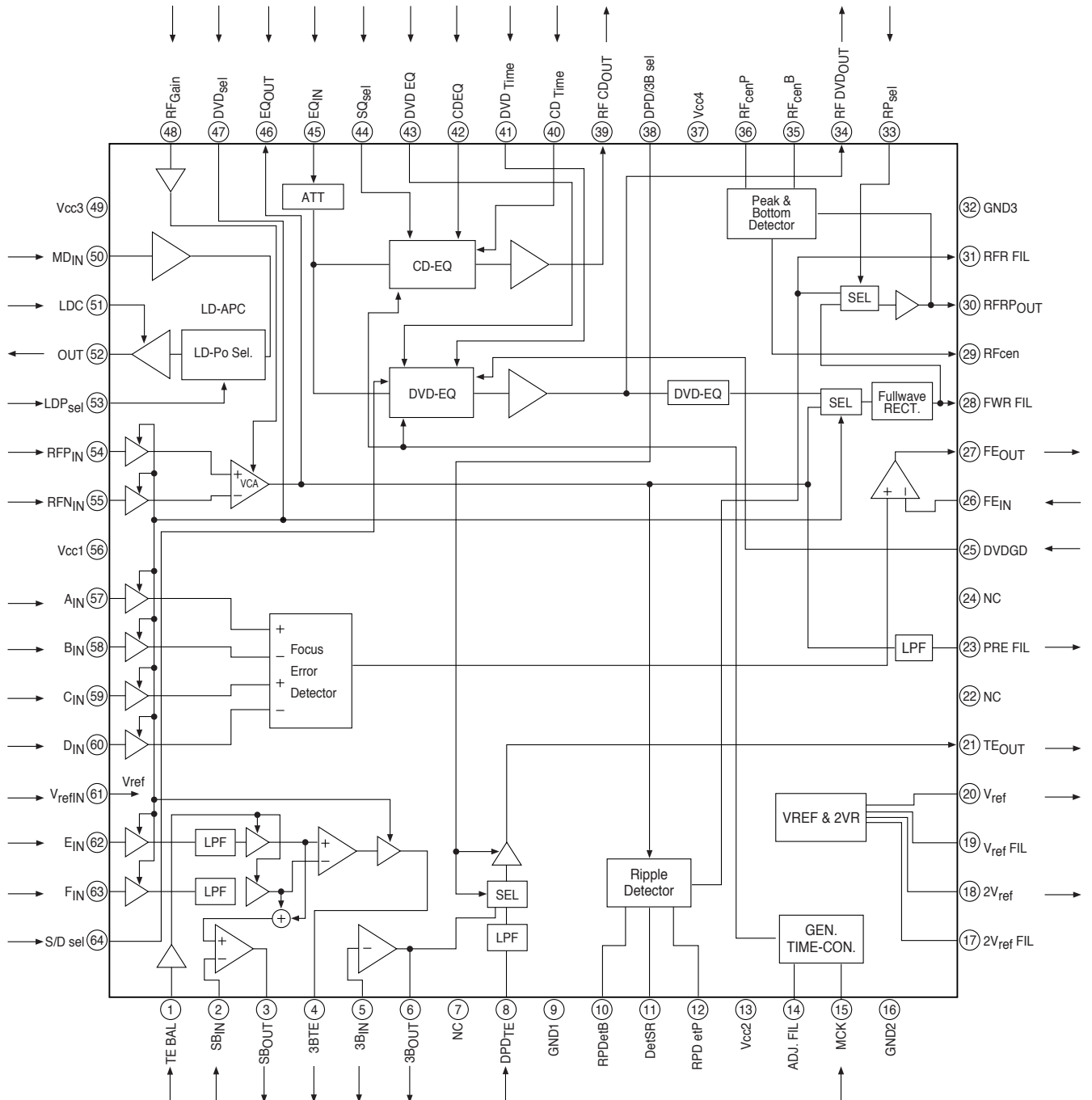

### 2-8-7 SIC (TC9420F)

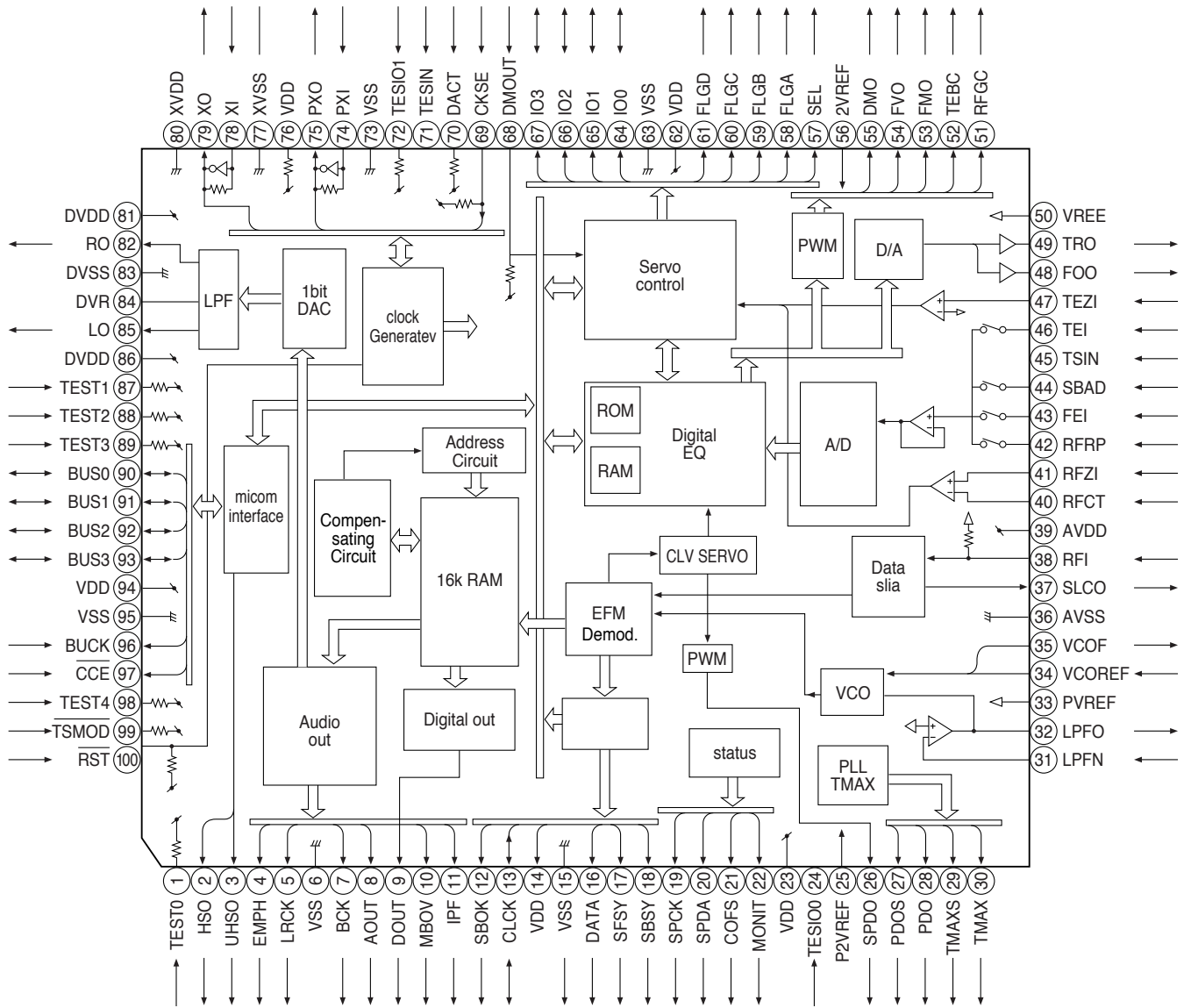

### 2-8-9 VIC1 (CL1620)

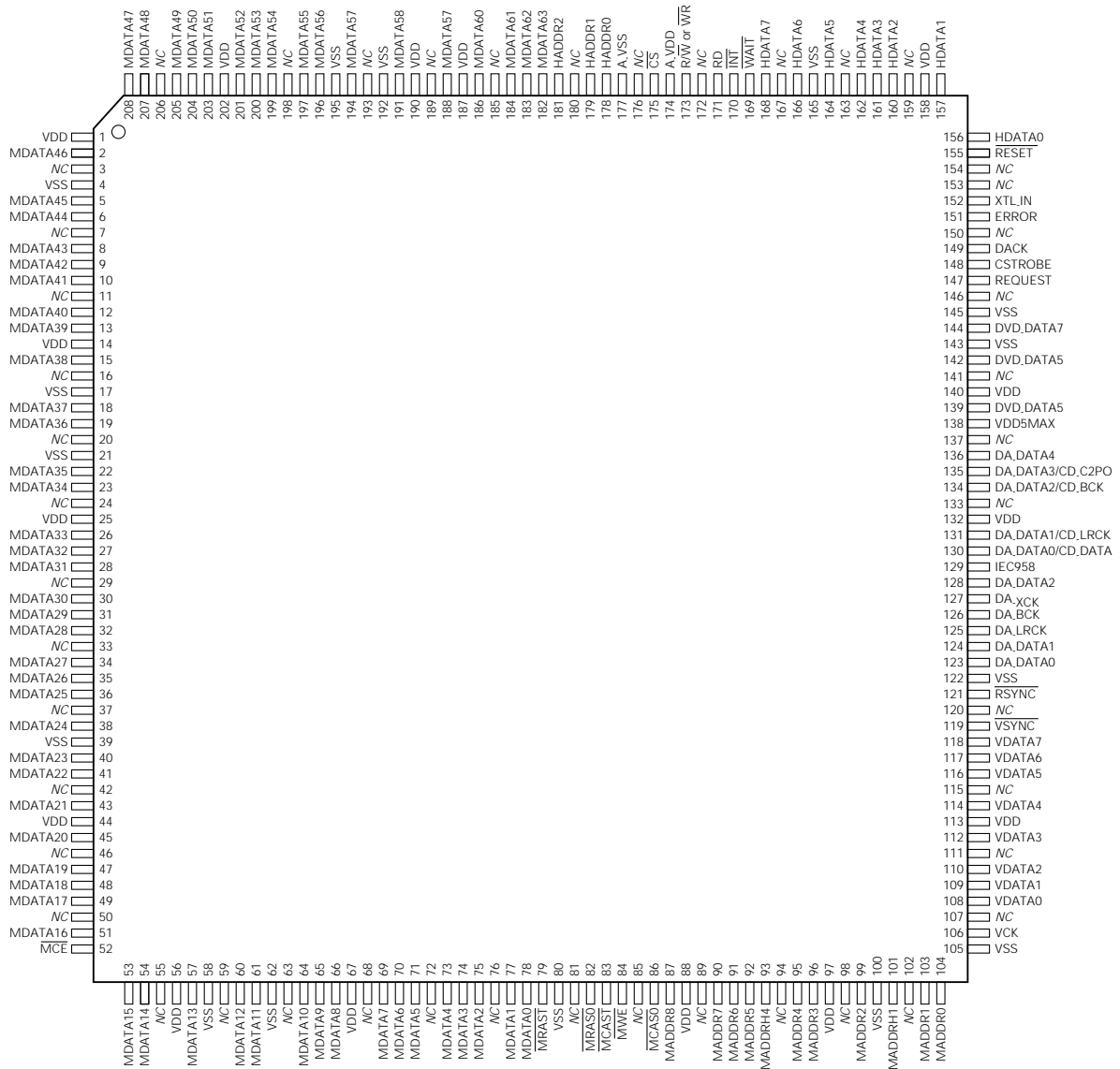

**2-8-10 VIC2 (AM27C4096)**

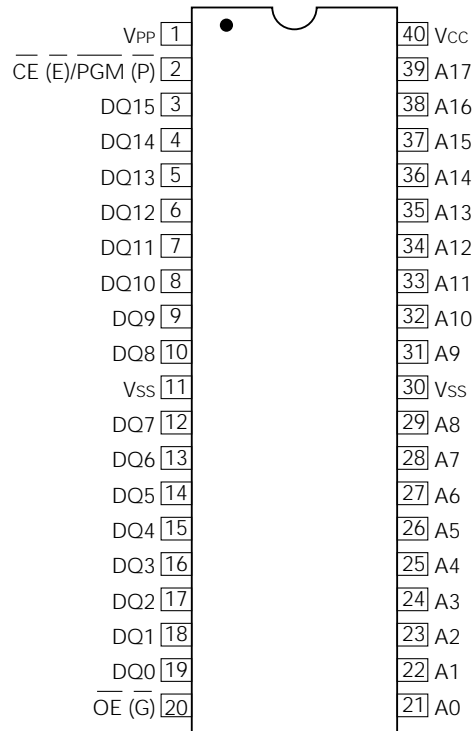

**2-8-11 VIC3/4/5/6/7 (KM416C254BJ)**

**2-8-12 VIC31 (STV0119)**

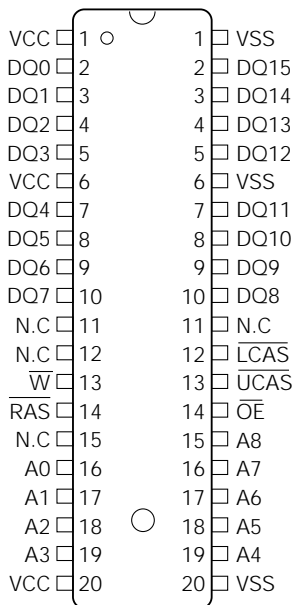

---

## 5. Thoubleshooting

---

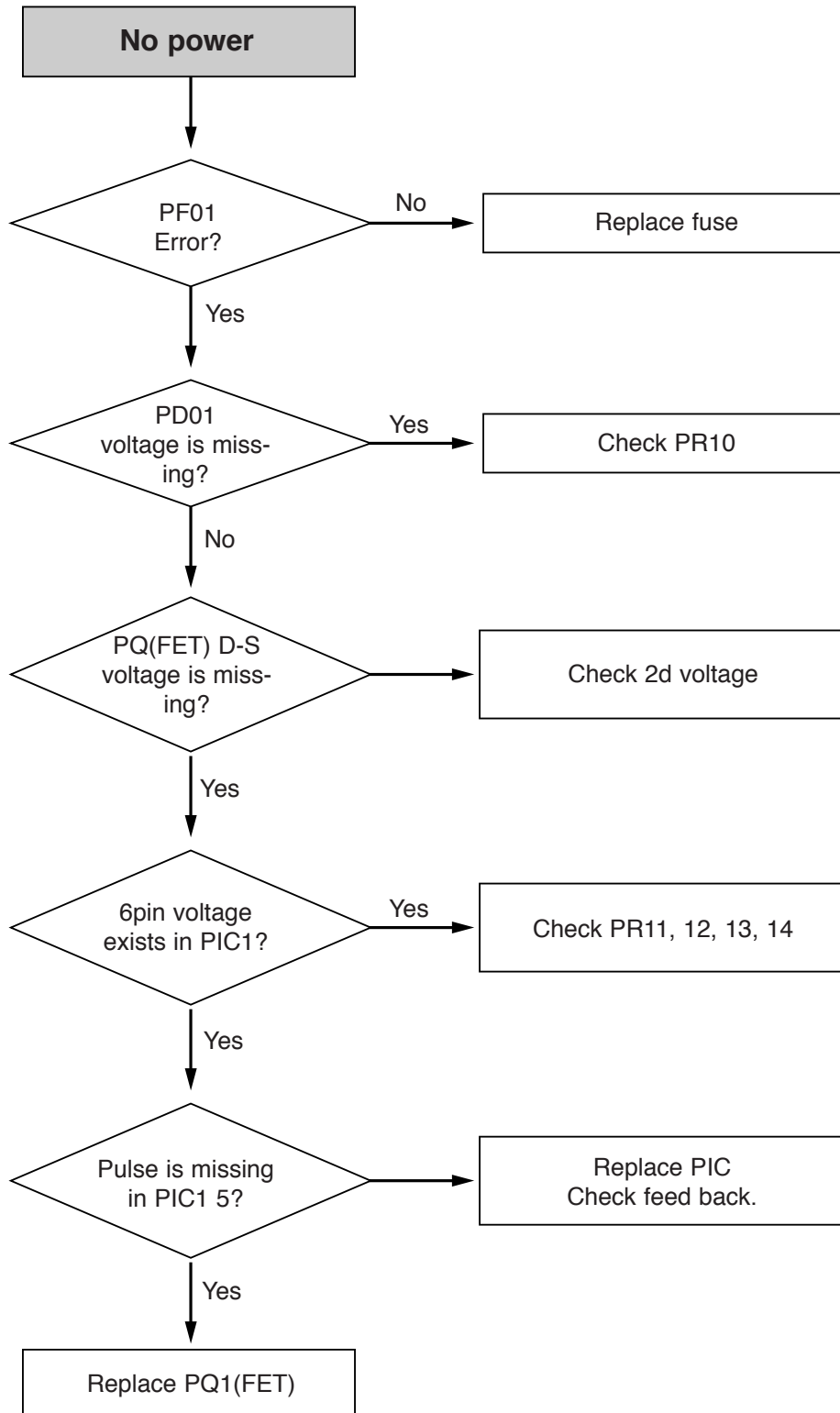

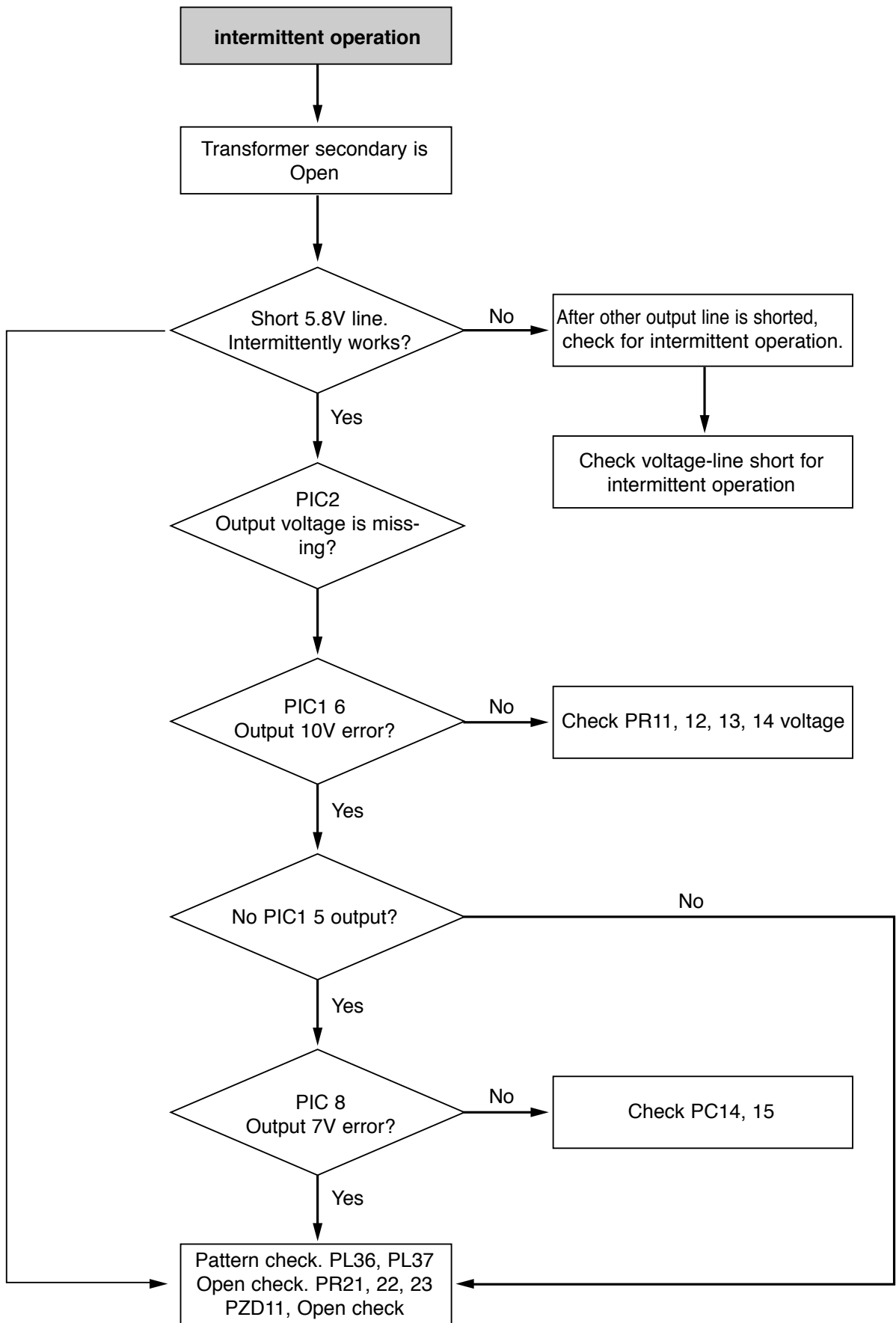

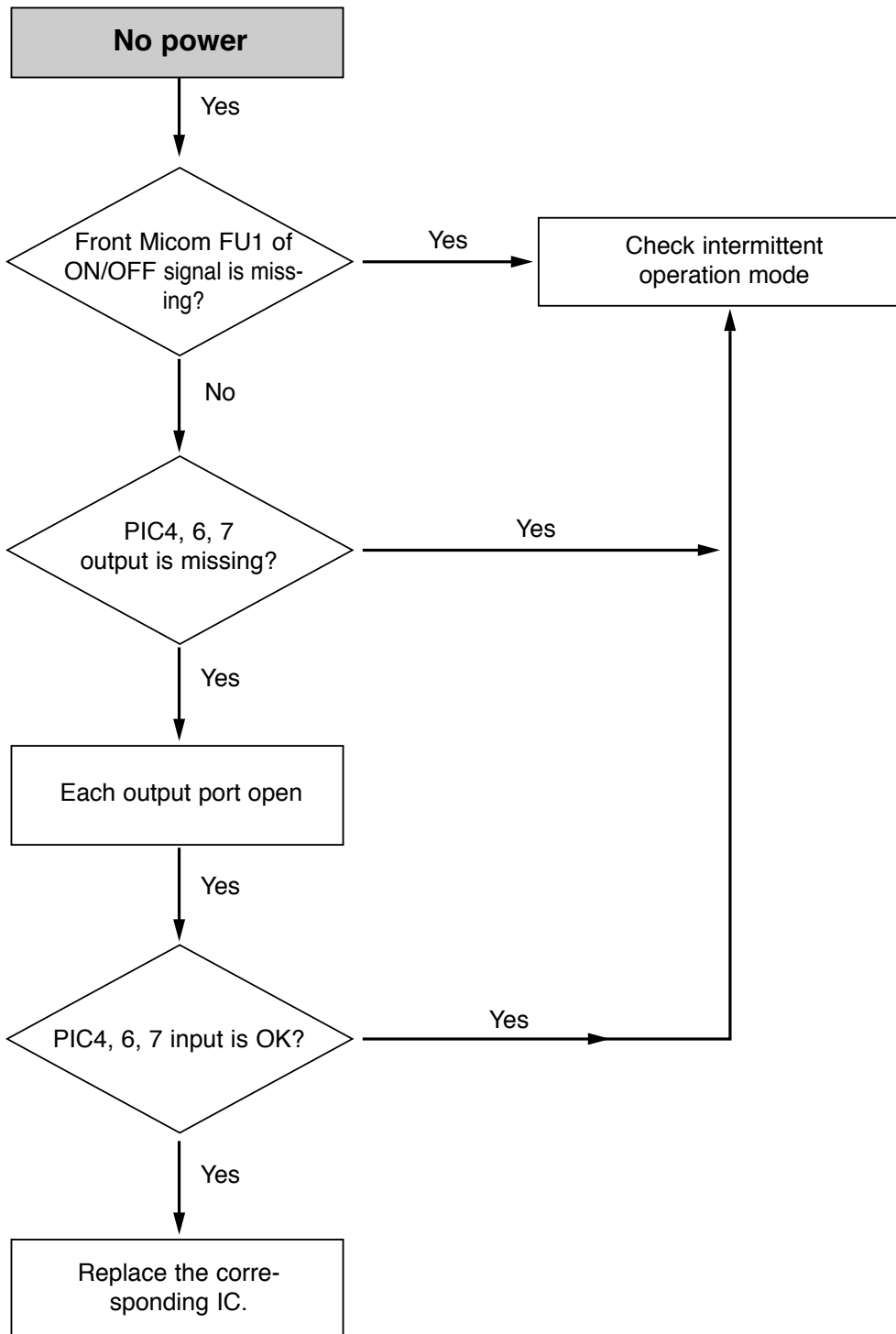



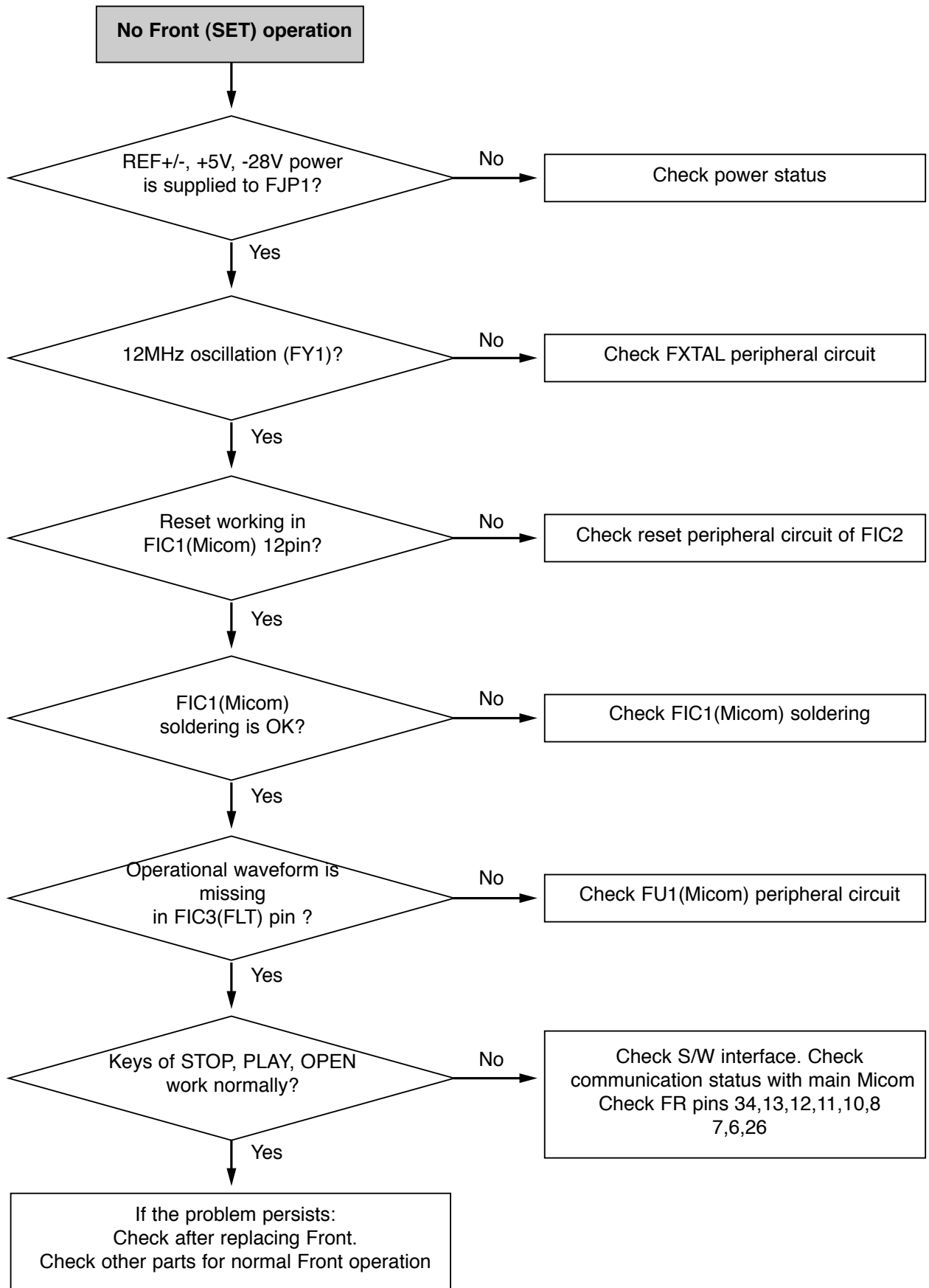

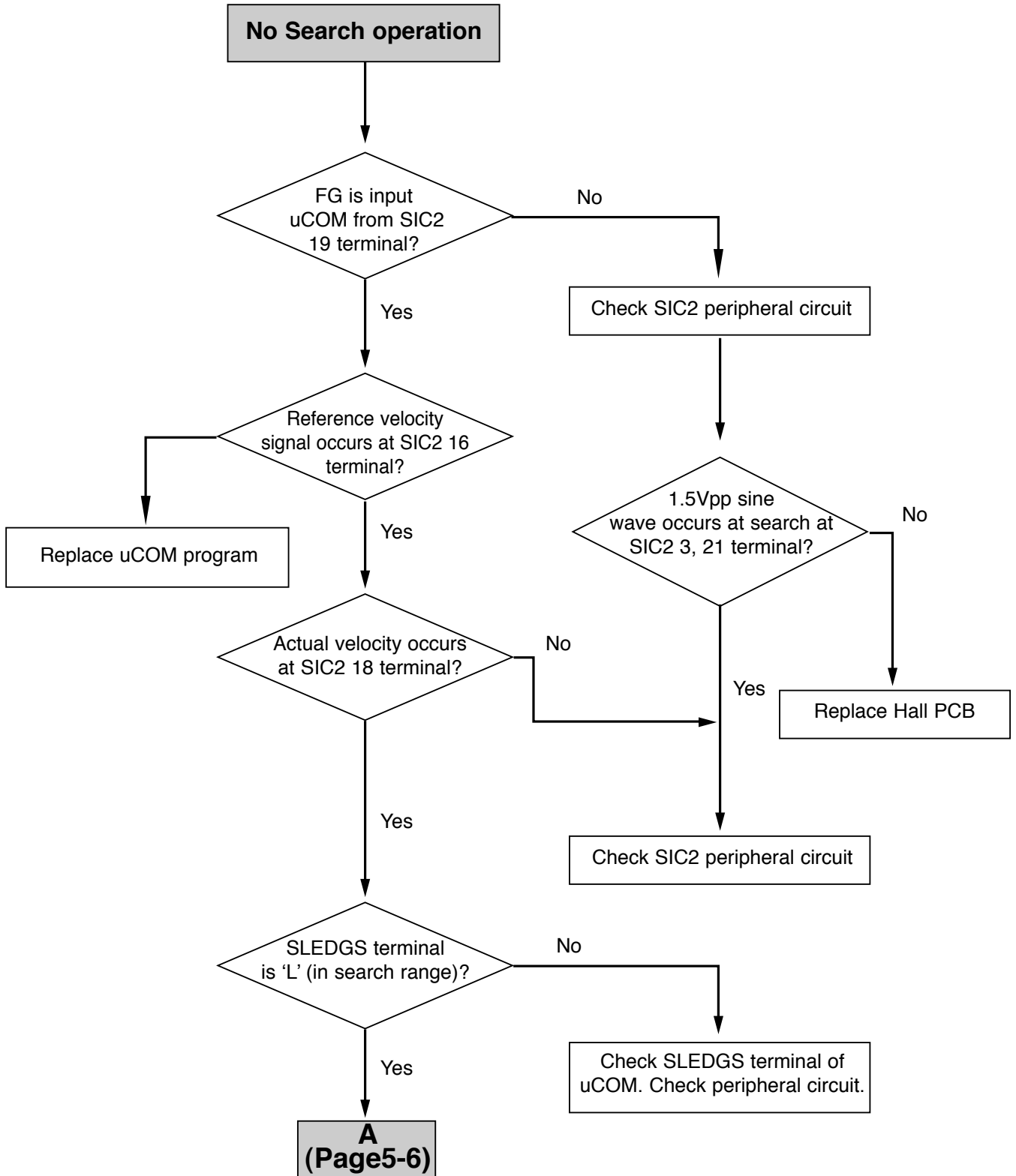

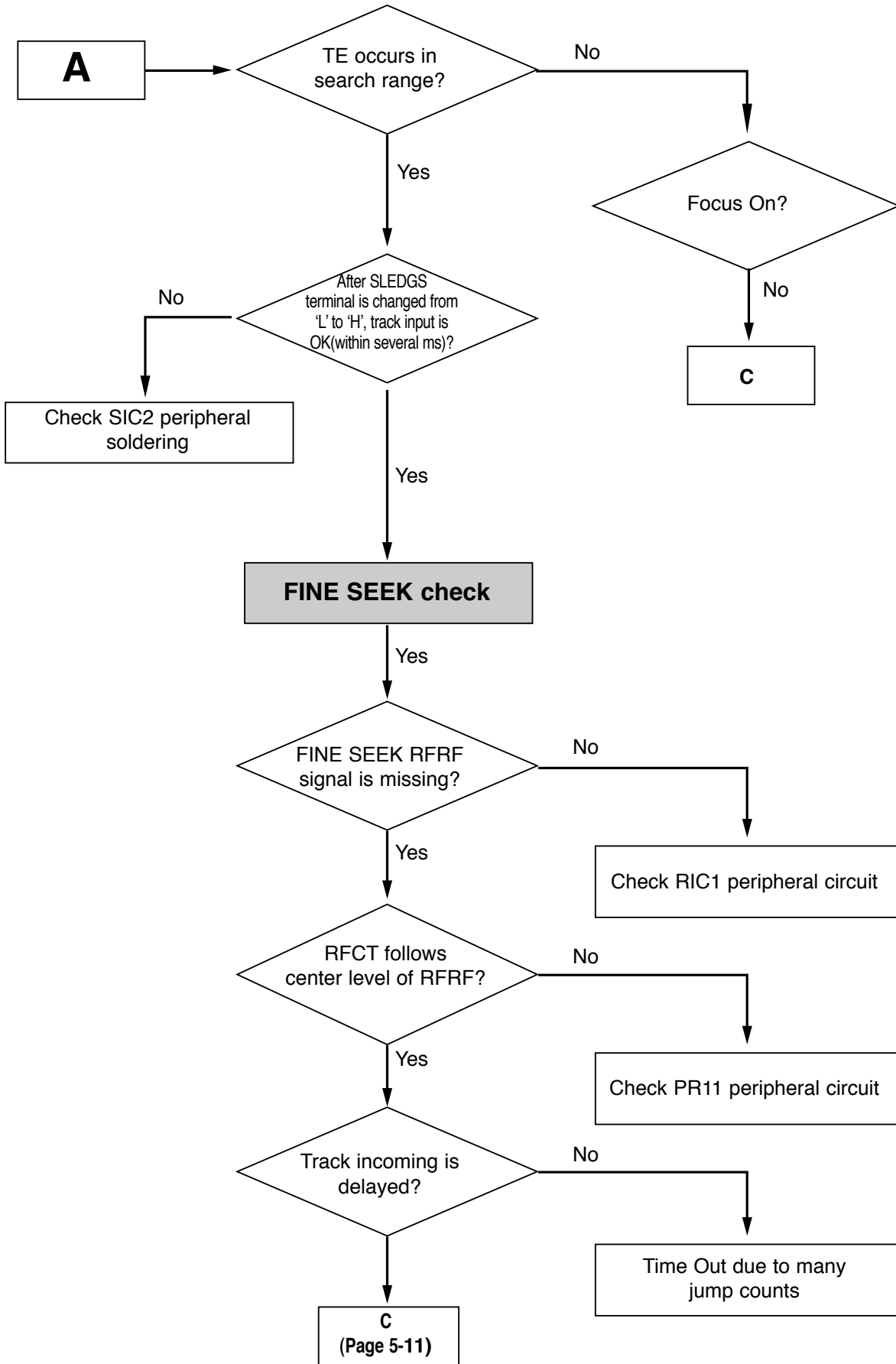

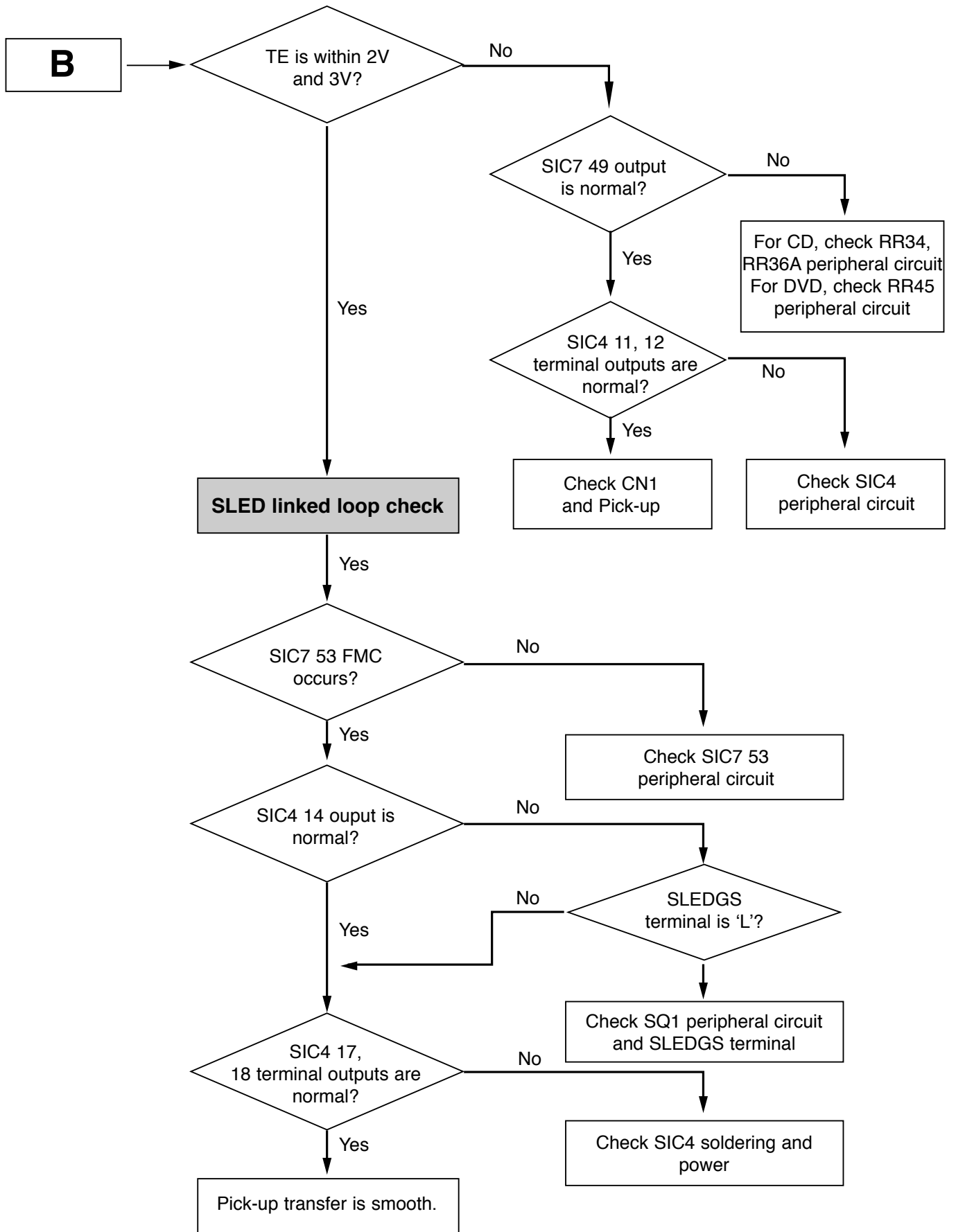

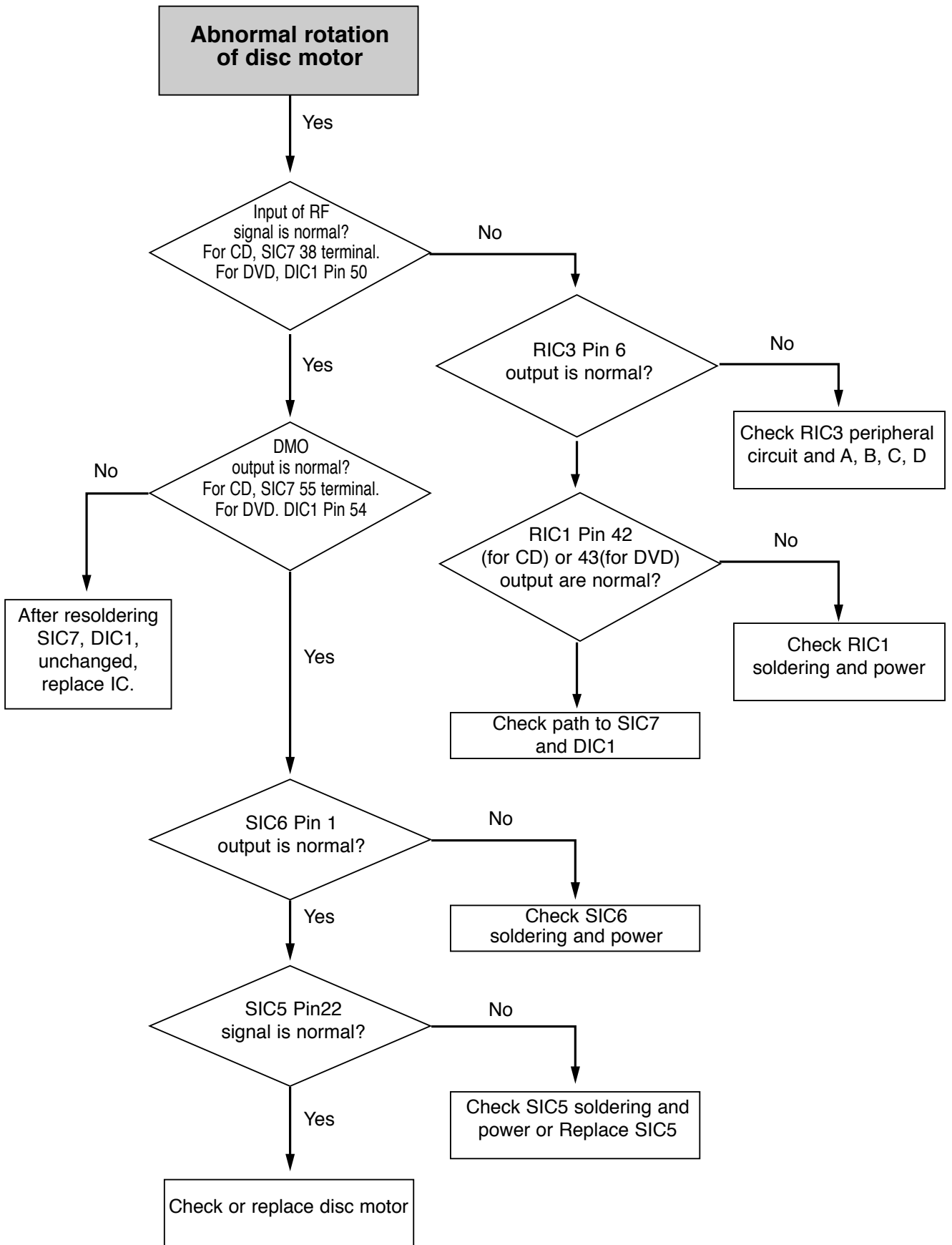

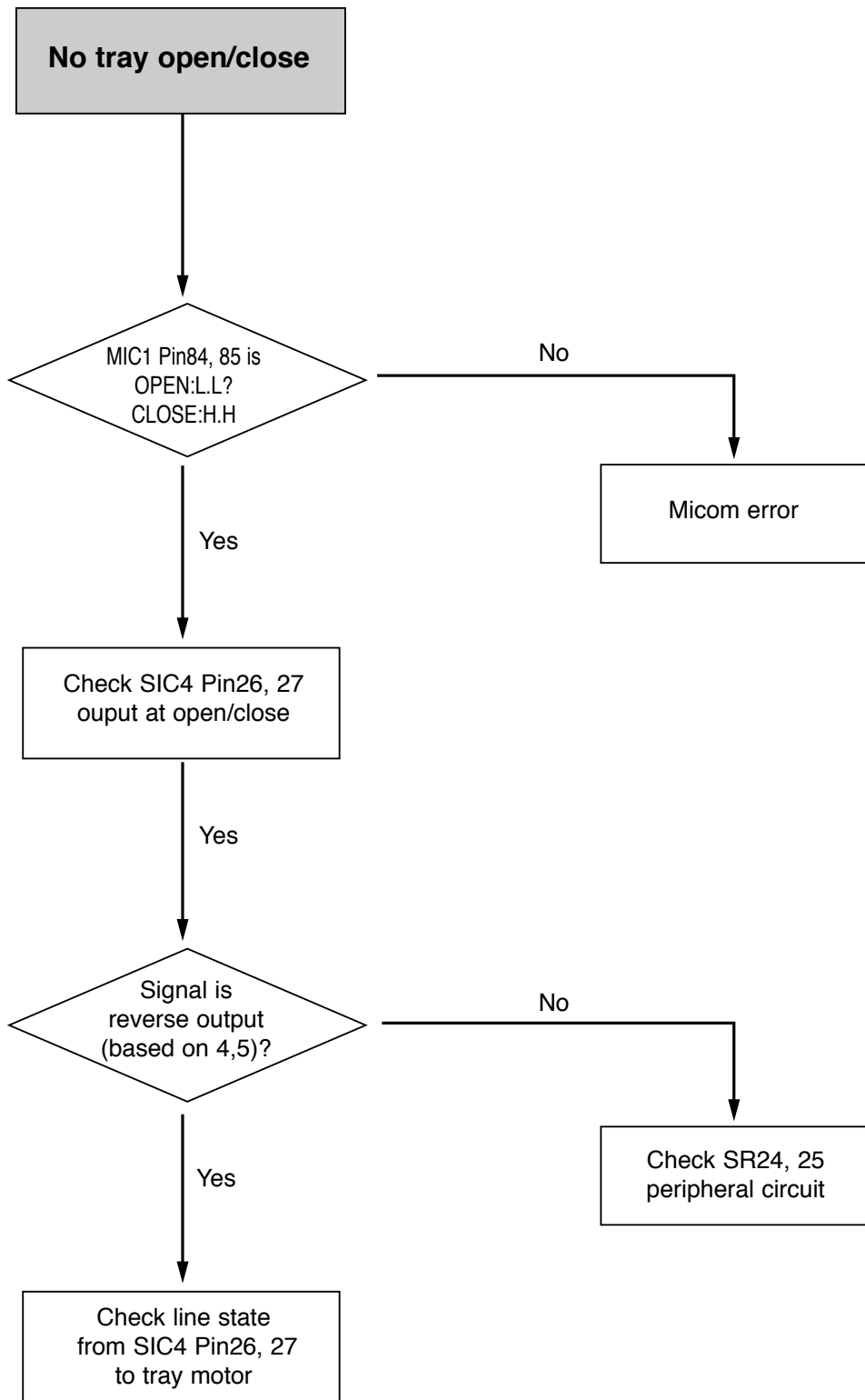

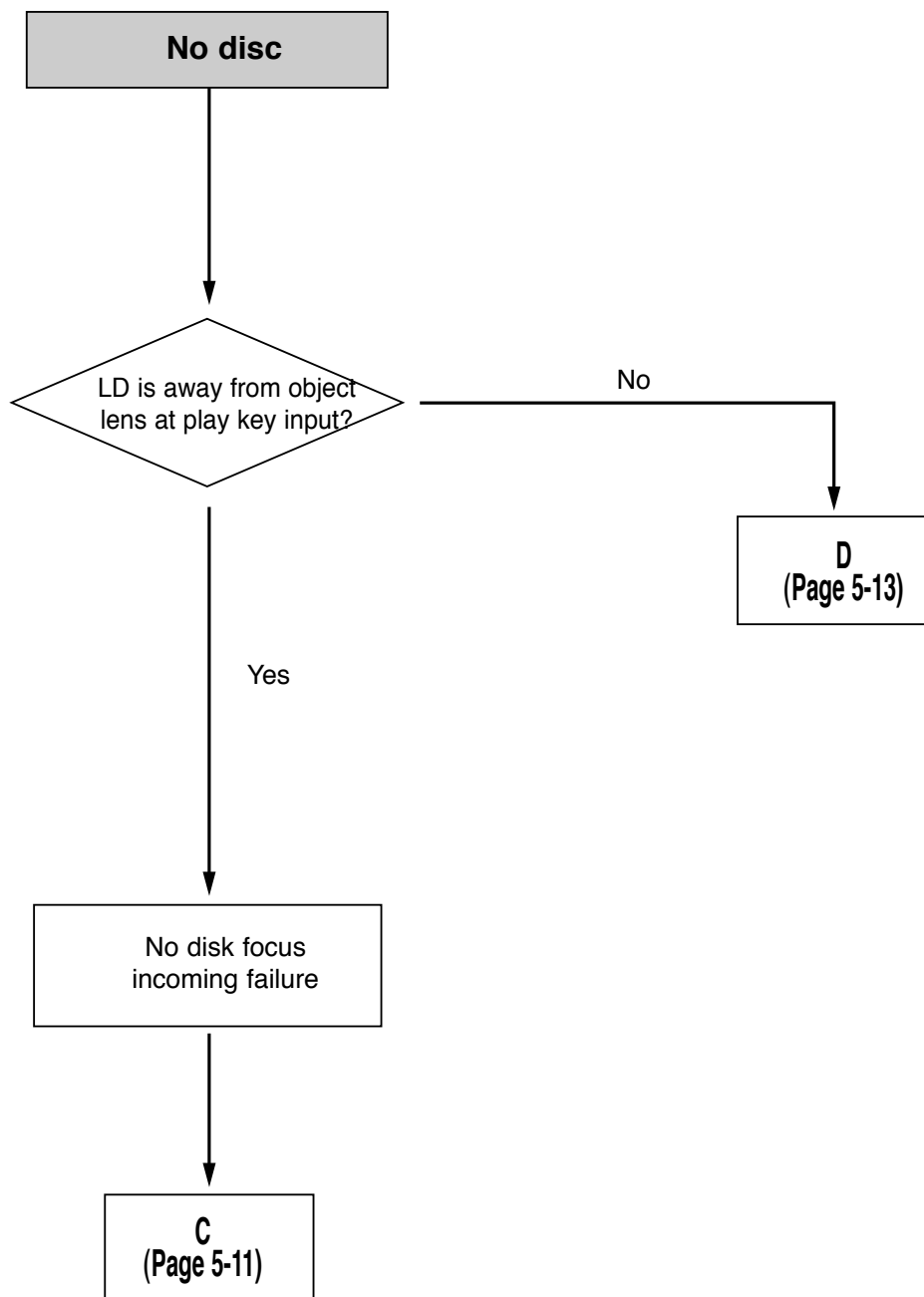

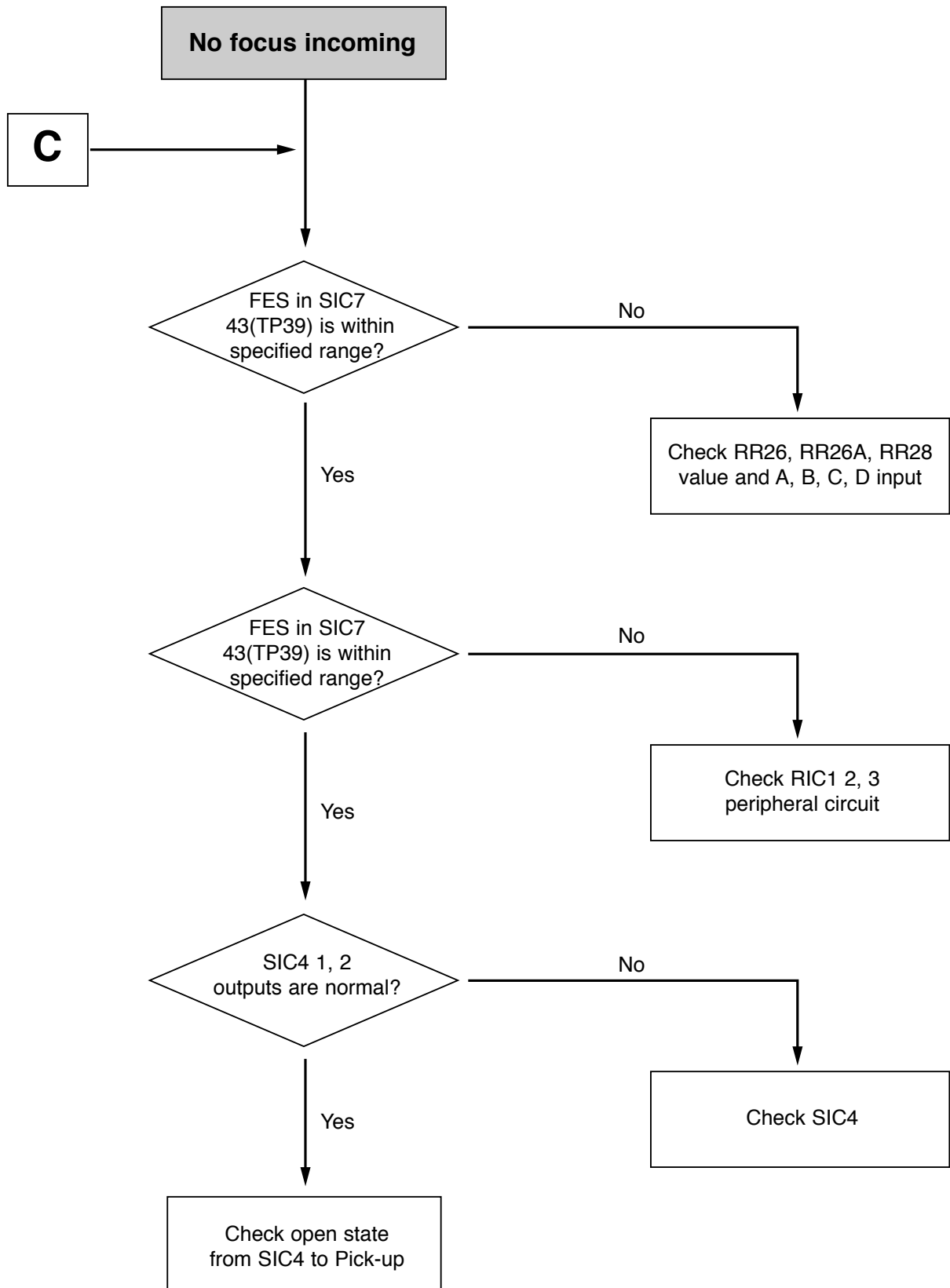



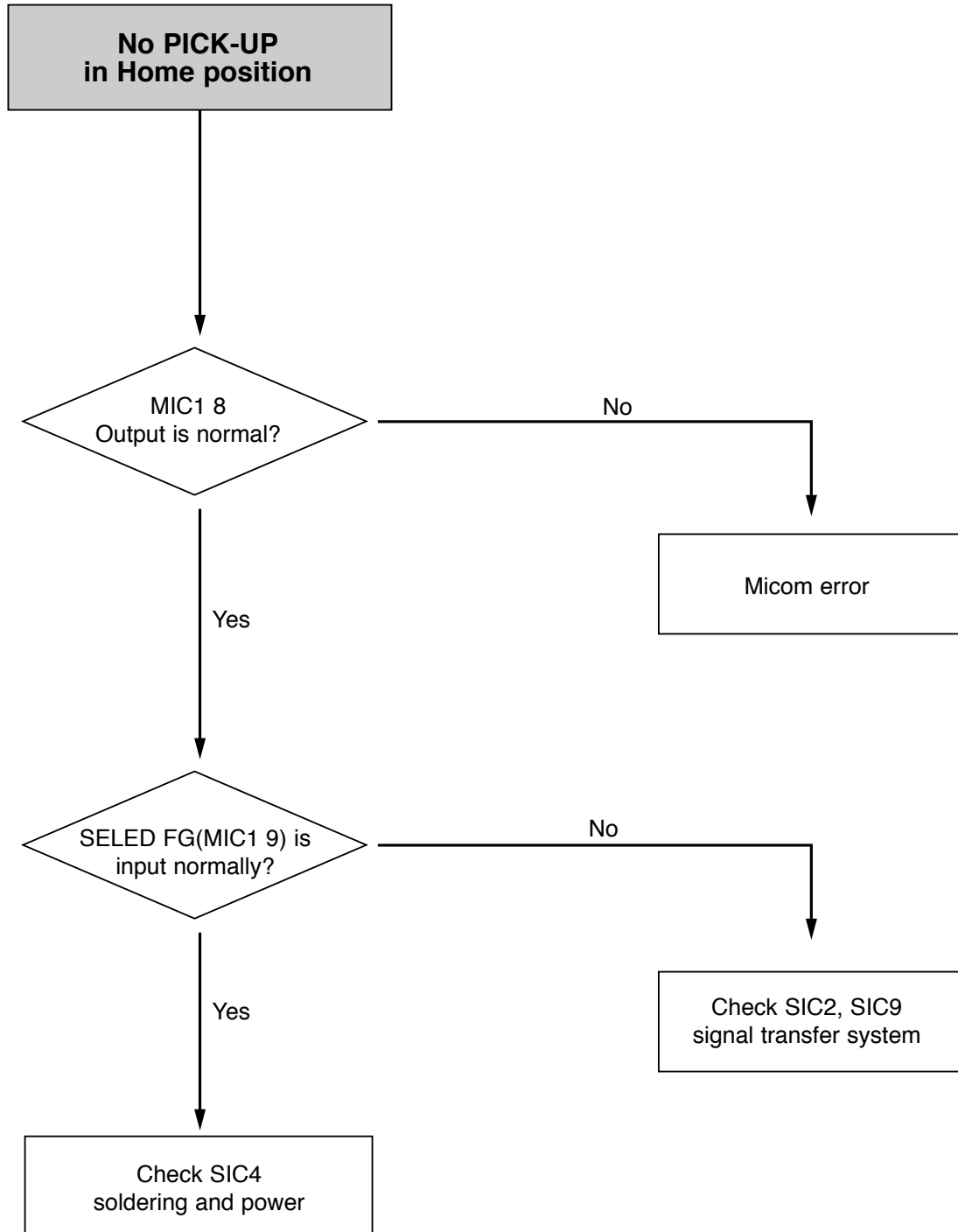

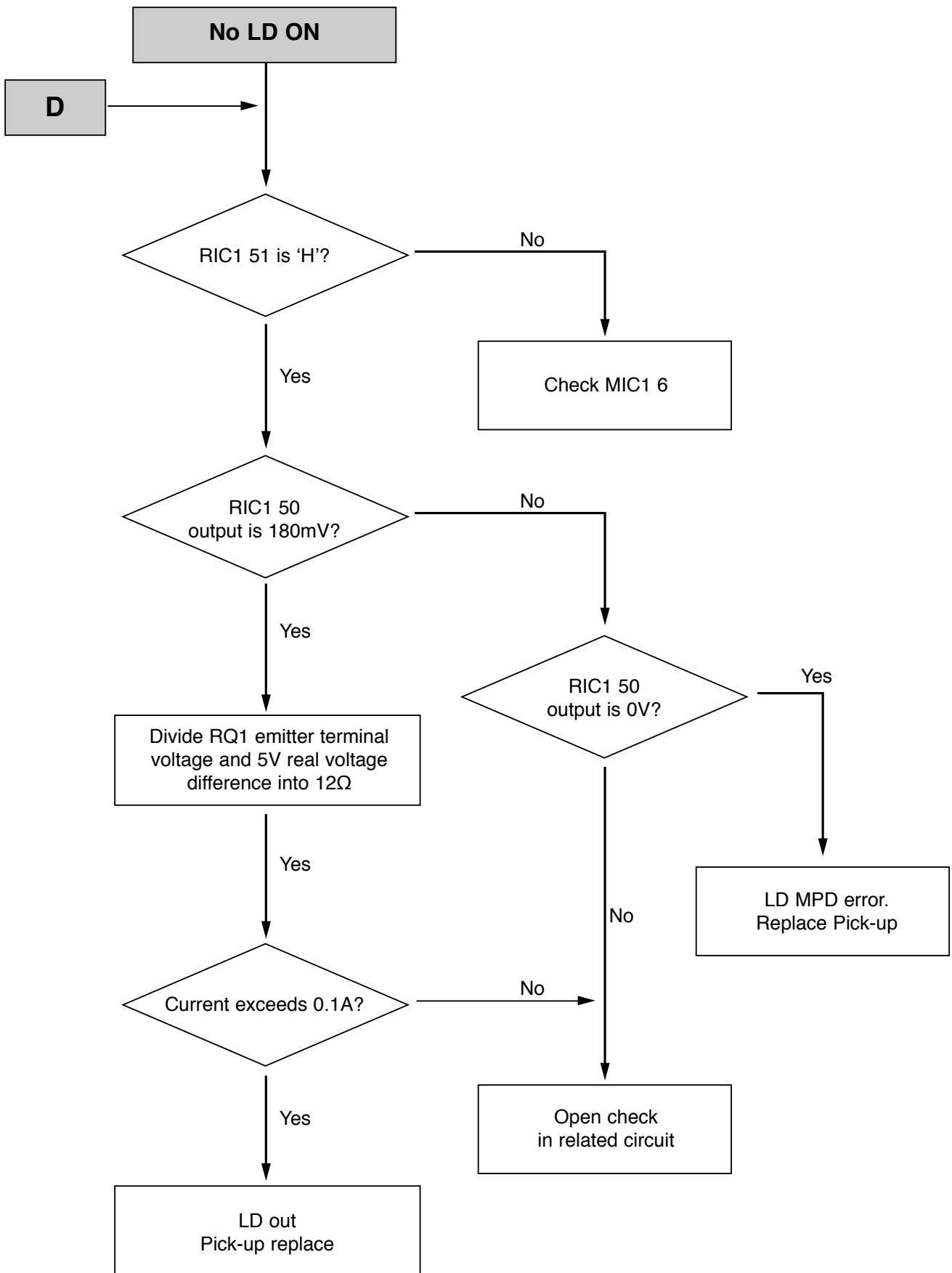

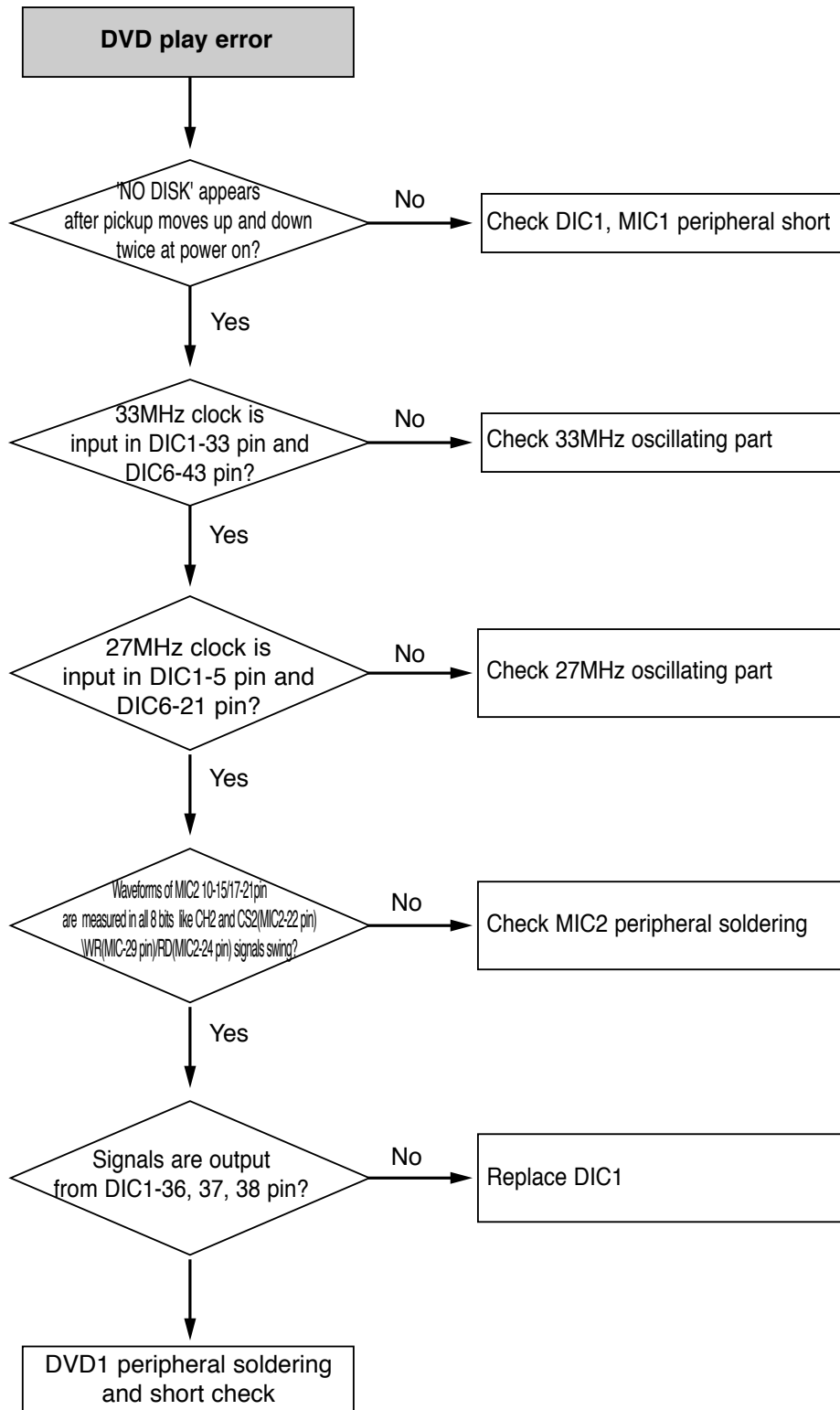

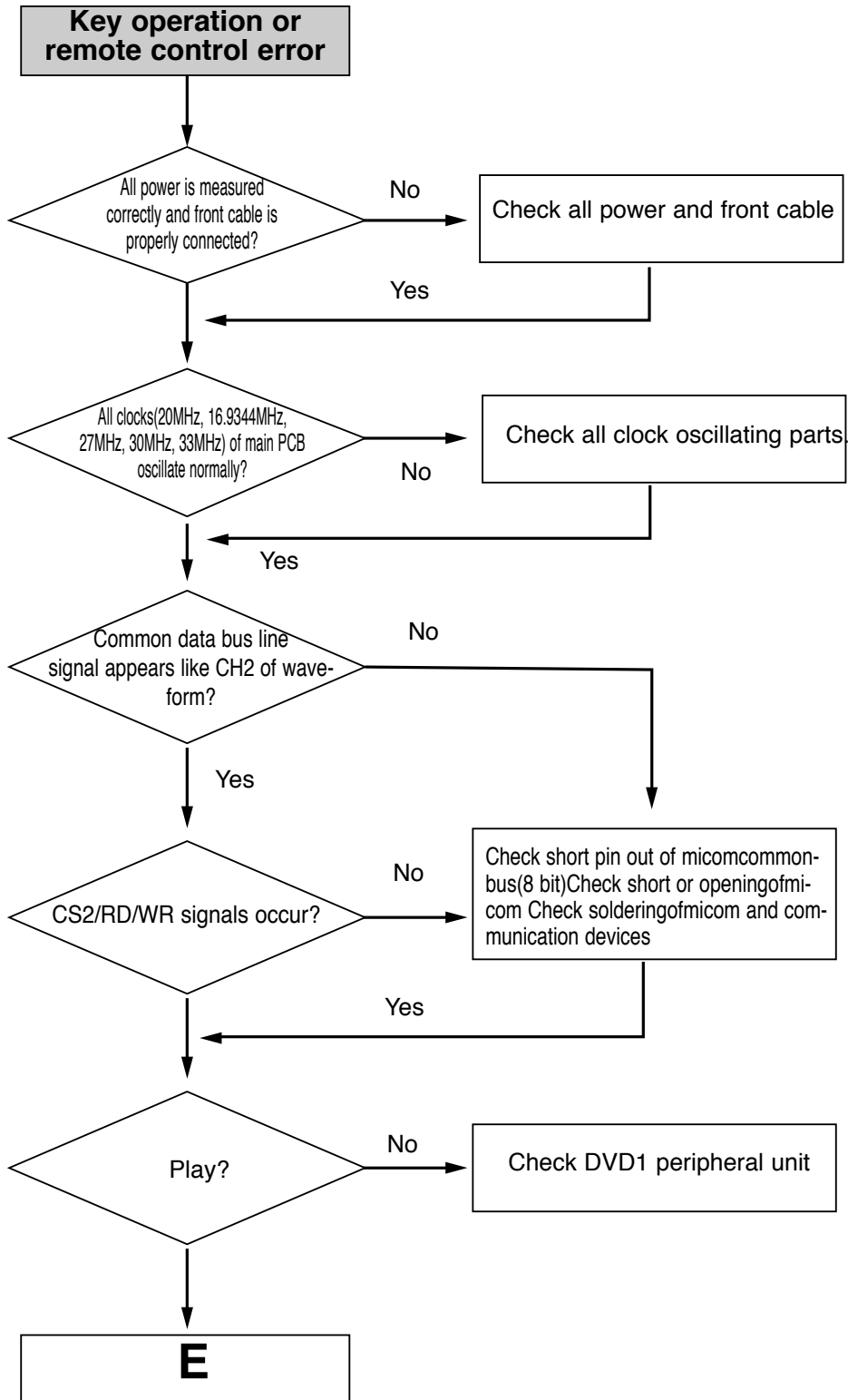

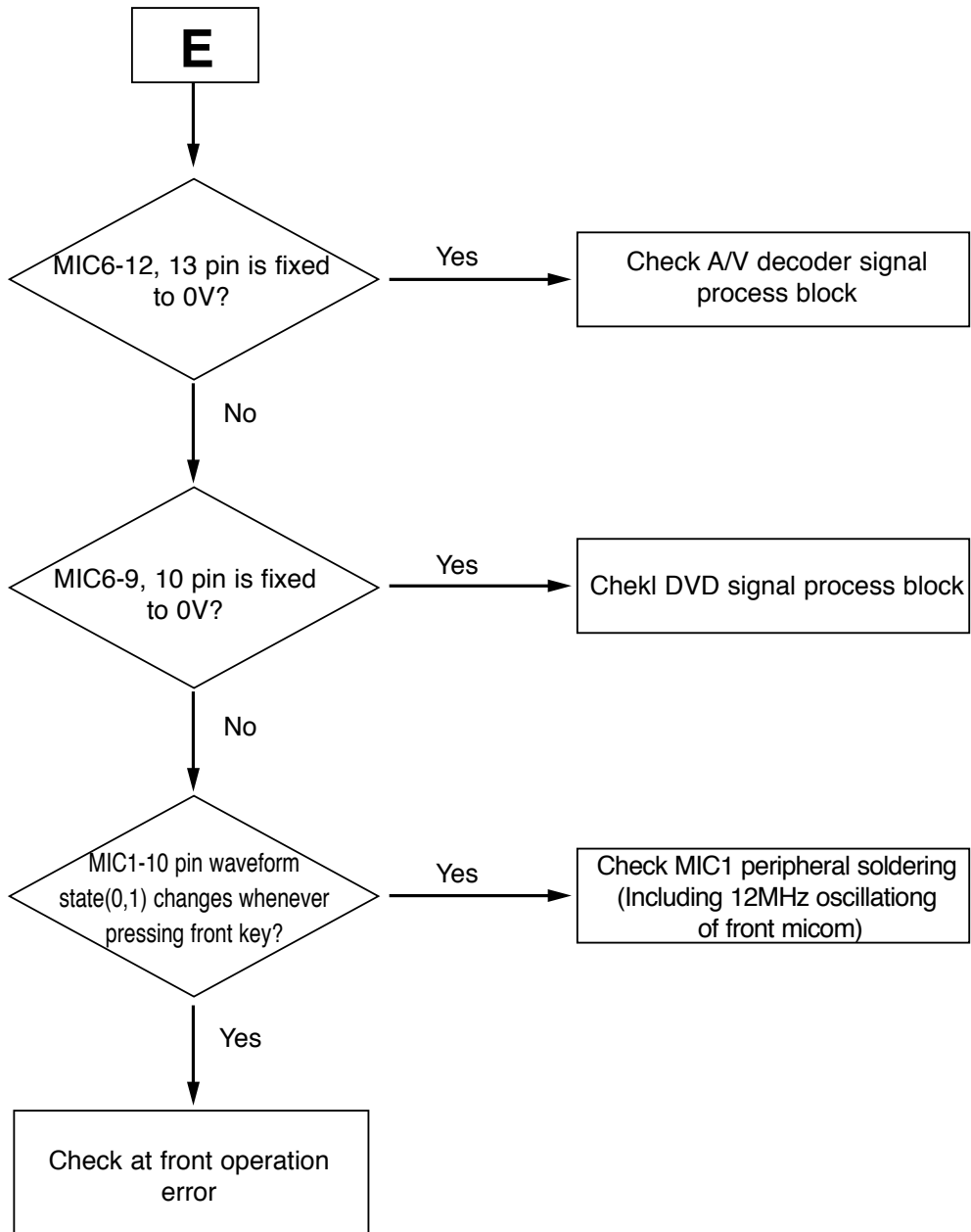

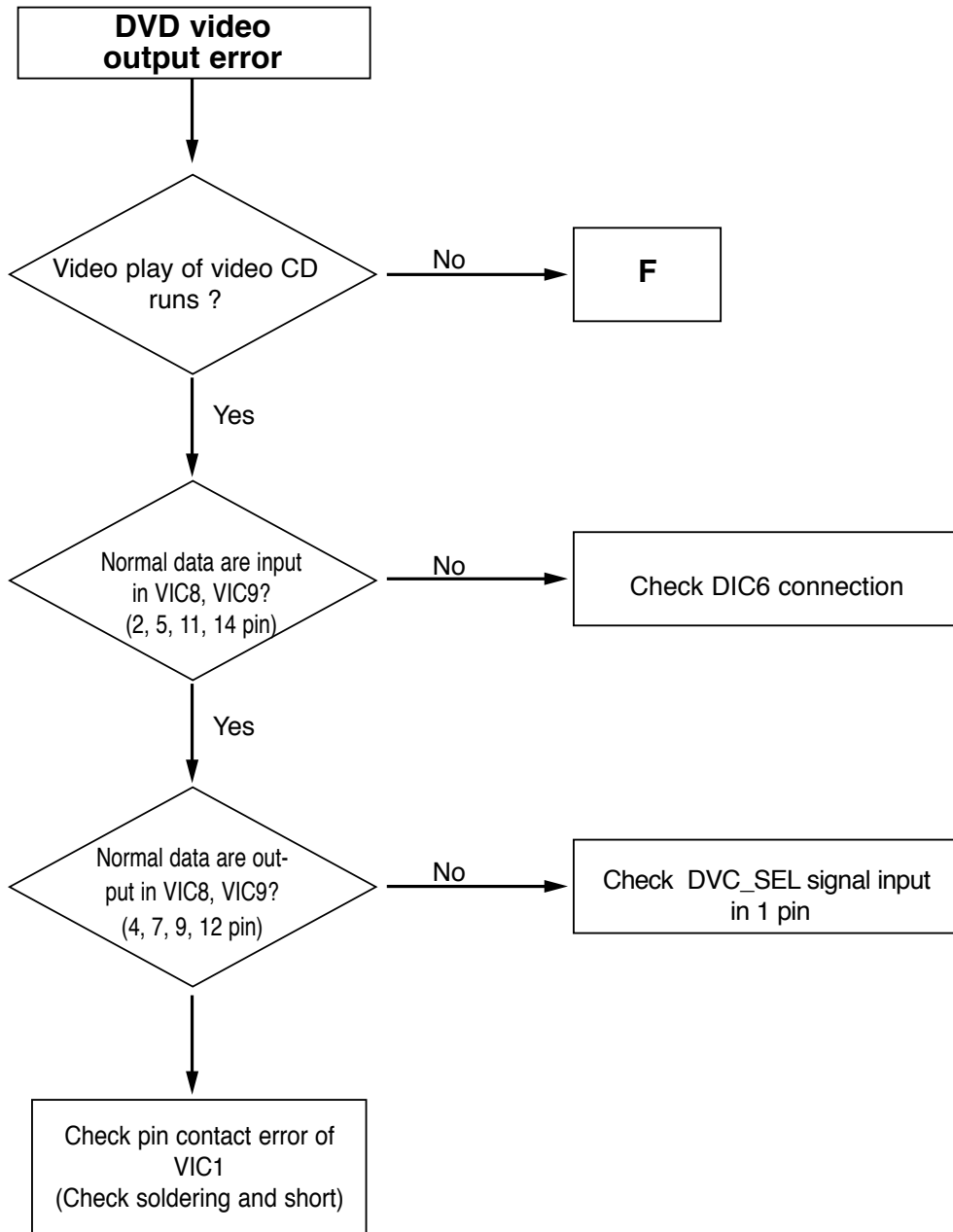

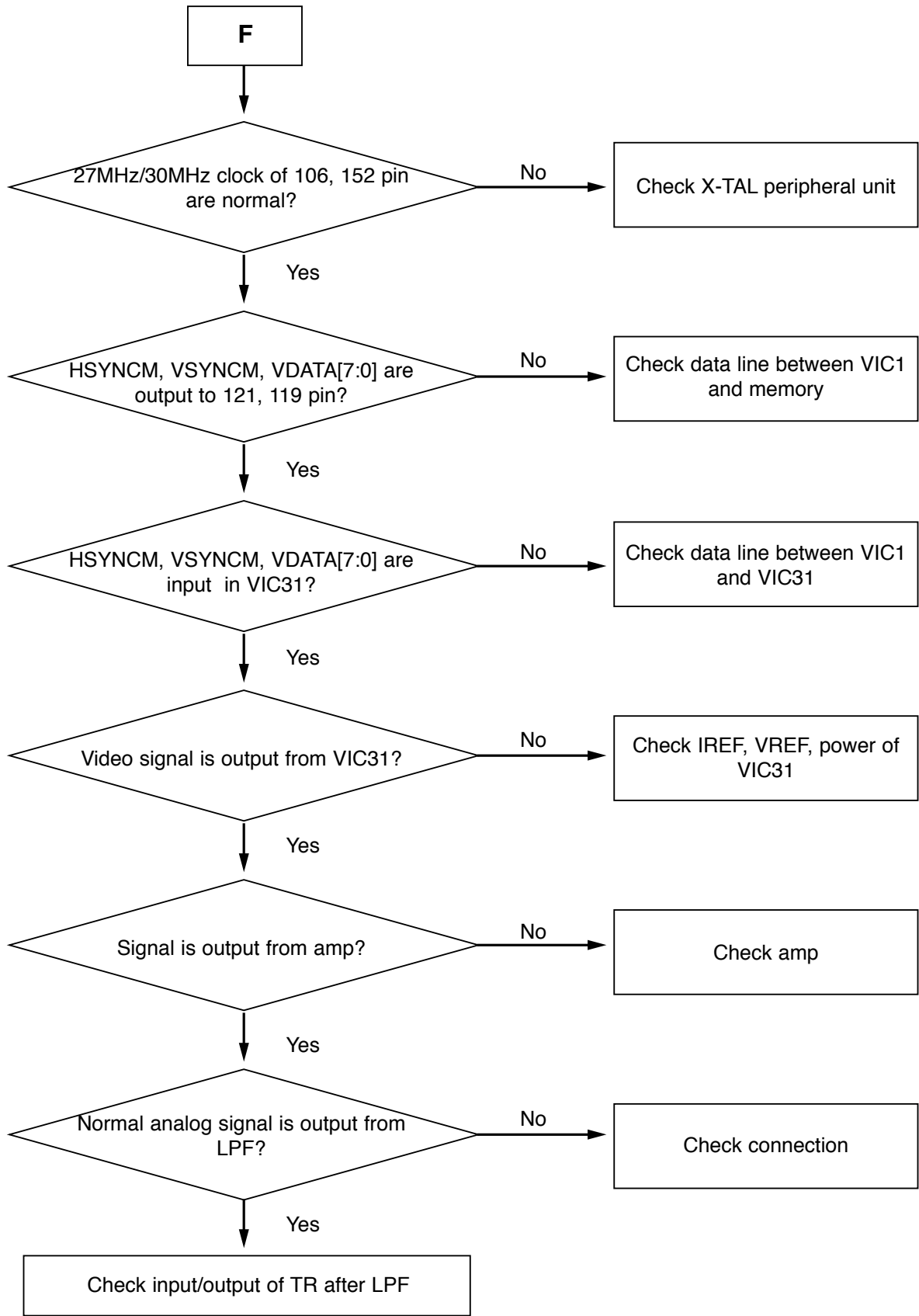

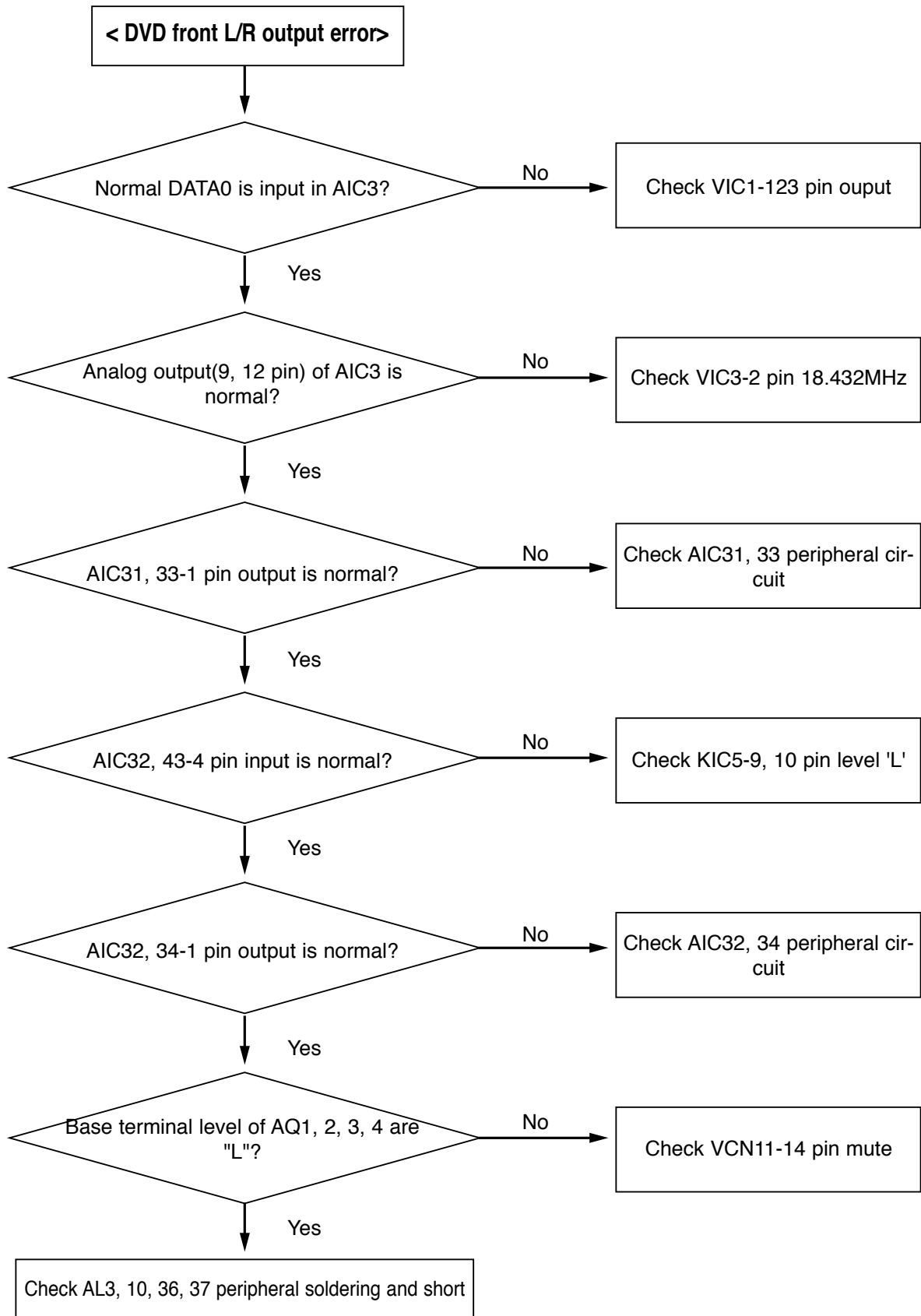



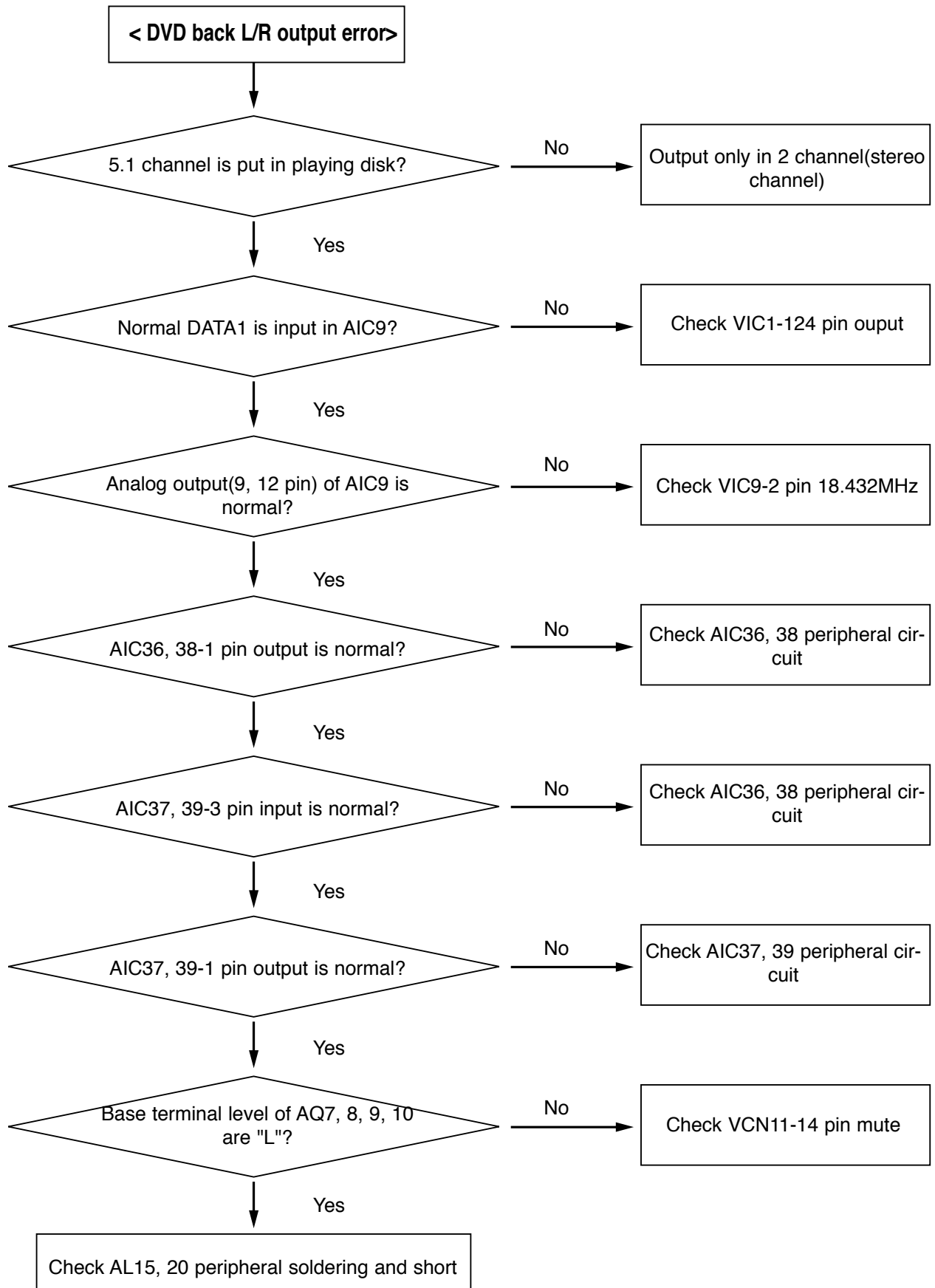

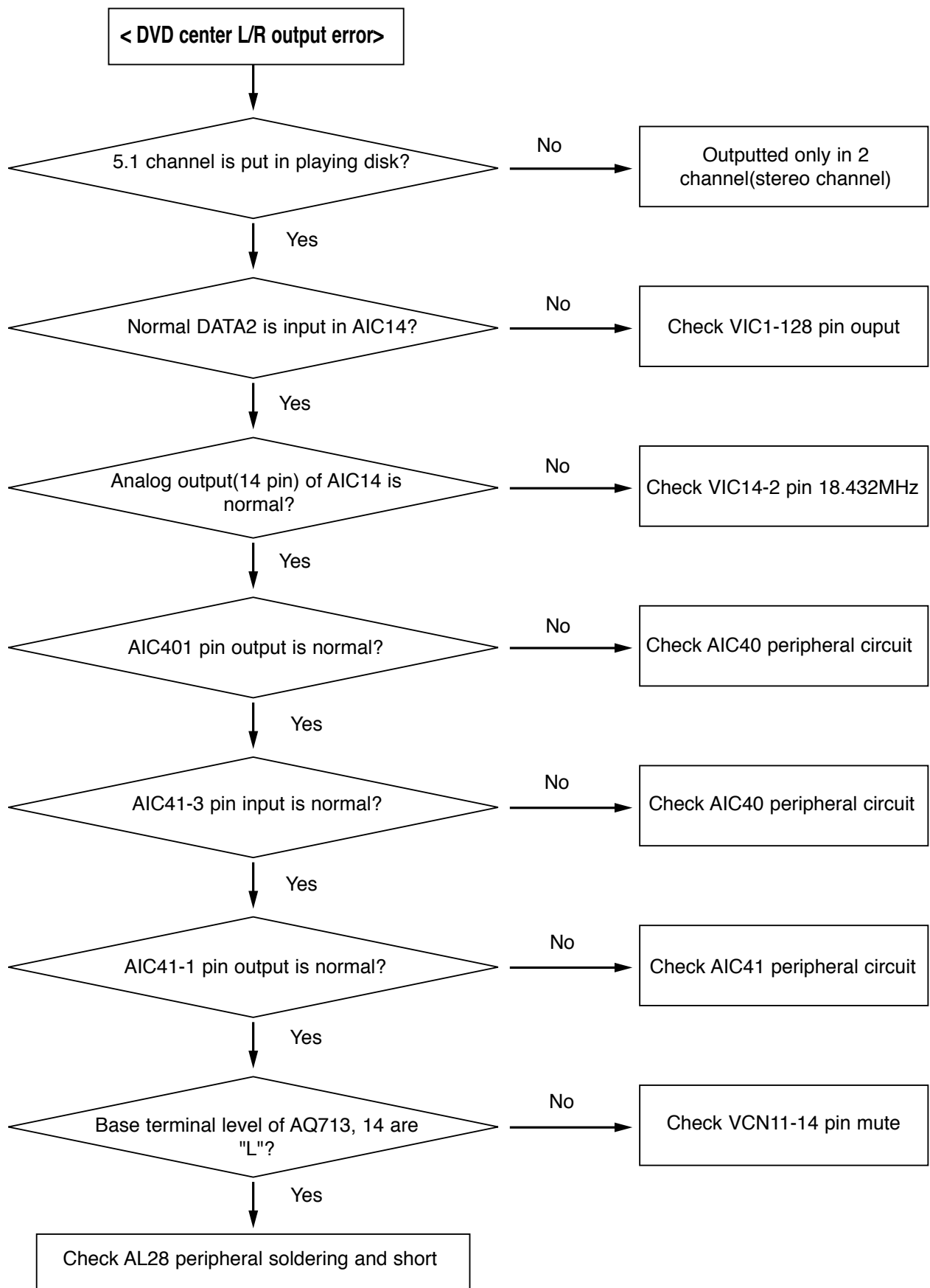

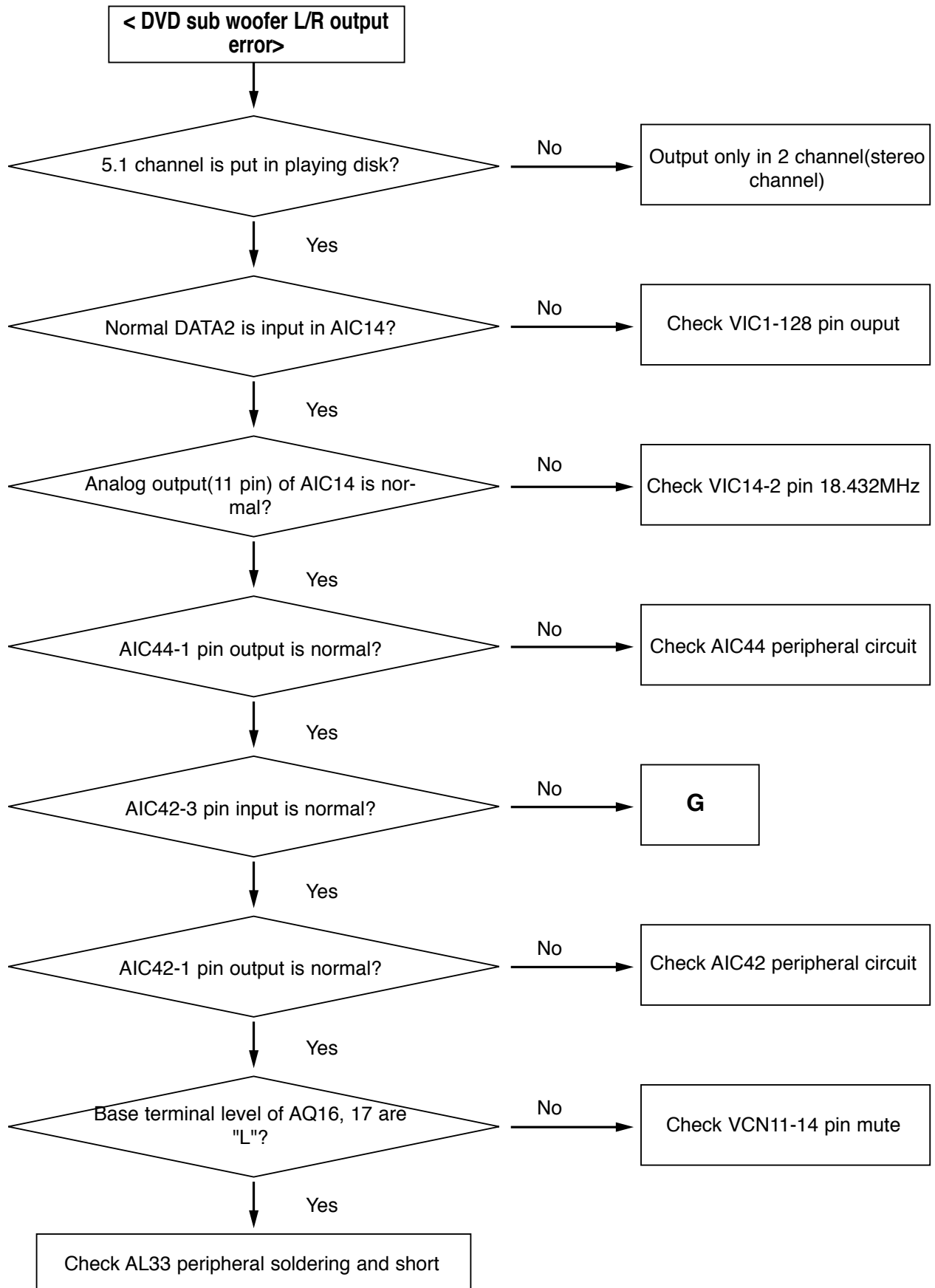

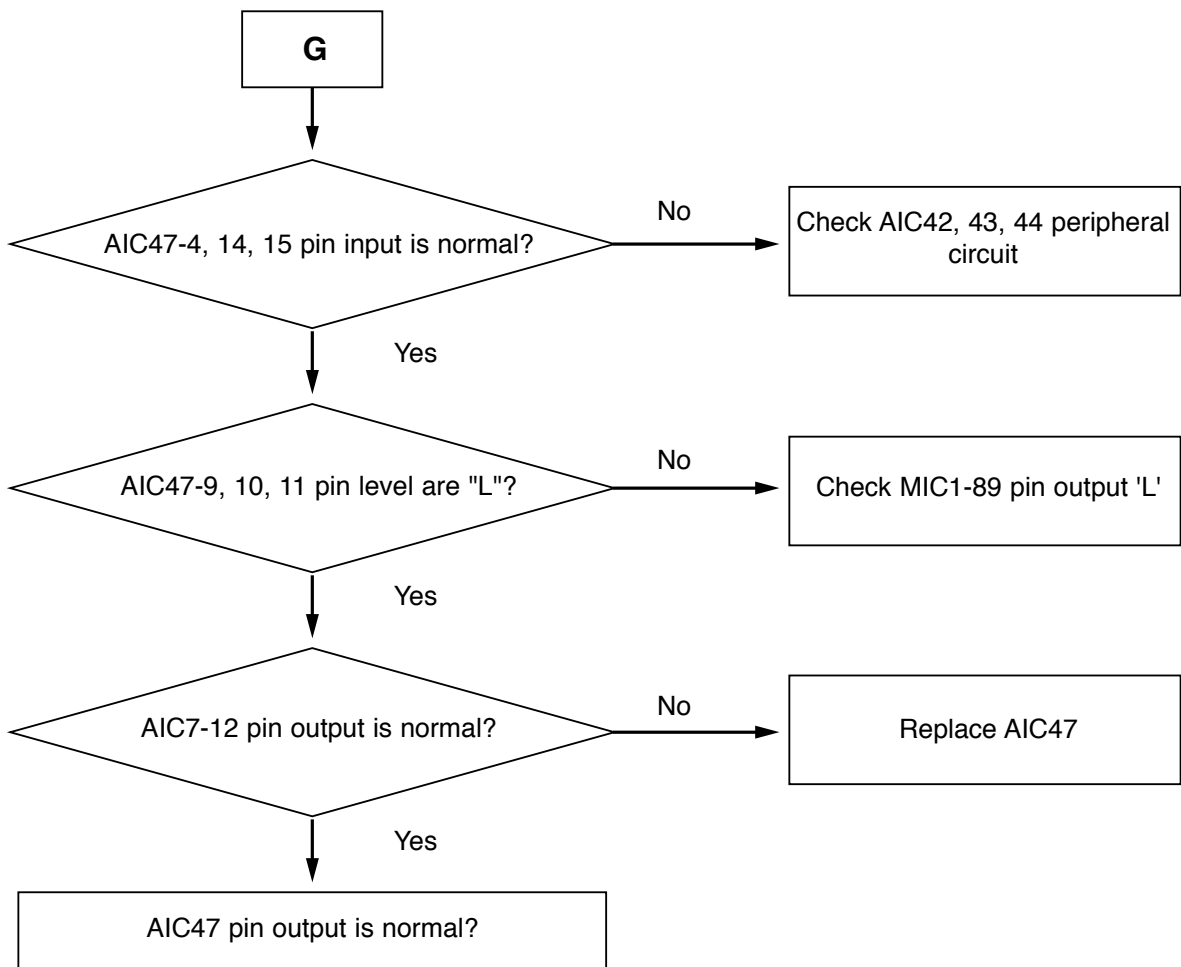

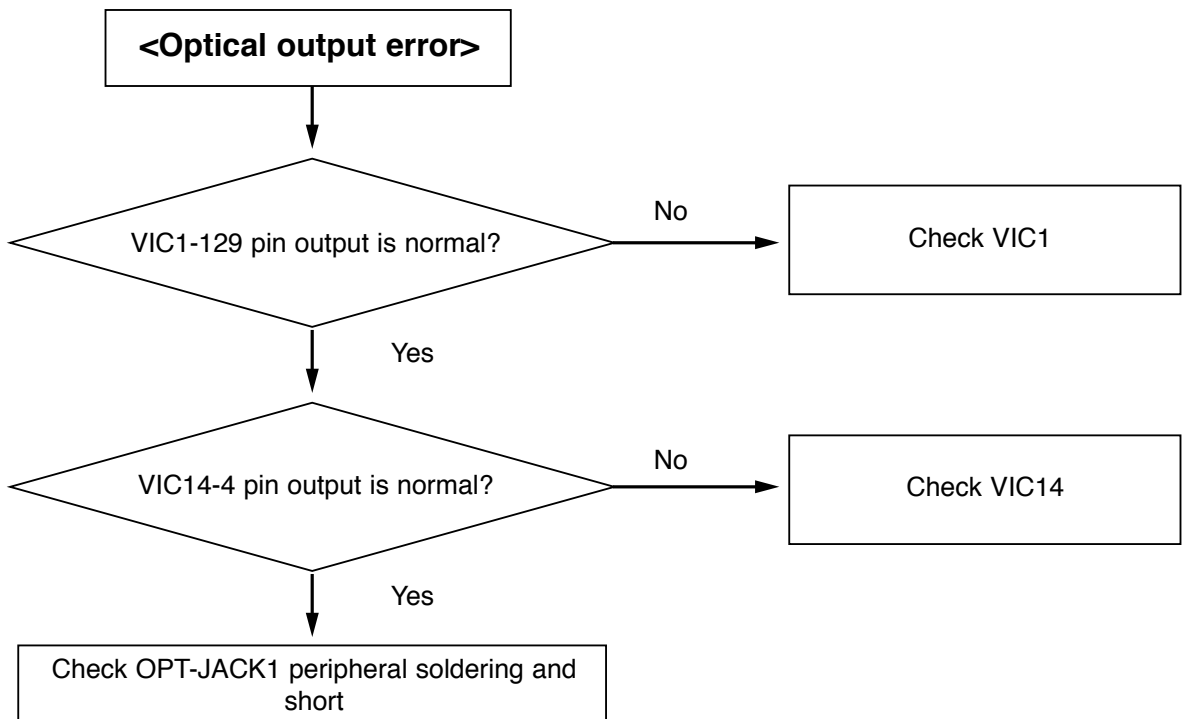

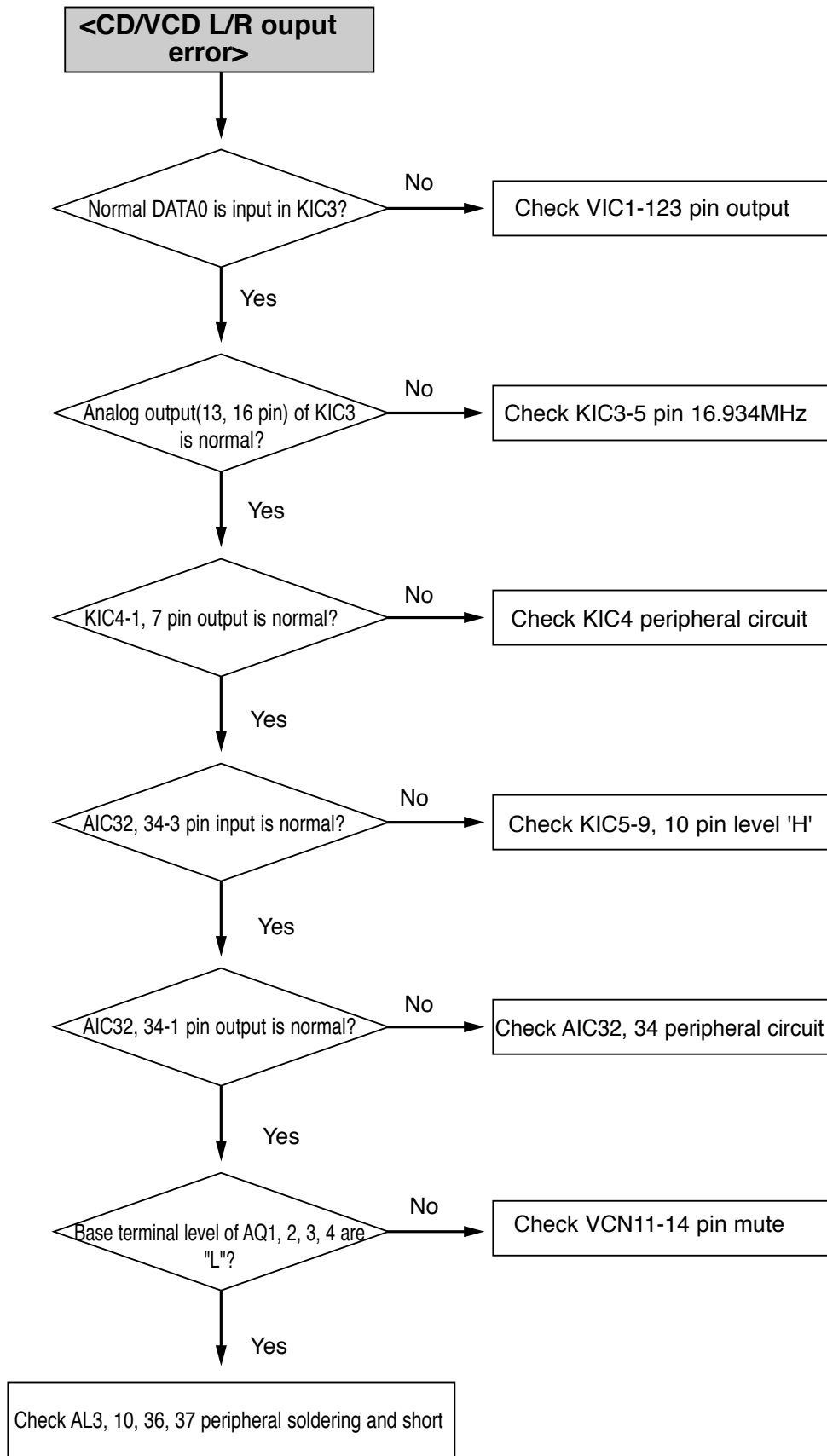

## MEMO

---

## 6. Exploded View and Parts List

---

	Page
6-1 Cabinet Assembly - - - - -	6-2
6-2 Mechanical Parts - - - - -	6-4
6-3 Remote Control - - - - -	6-6



# 6-1 Cabinet Assembly

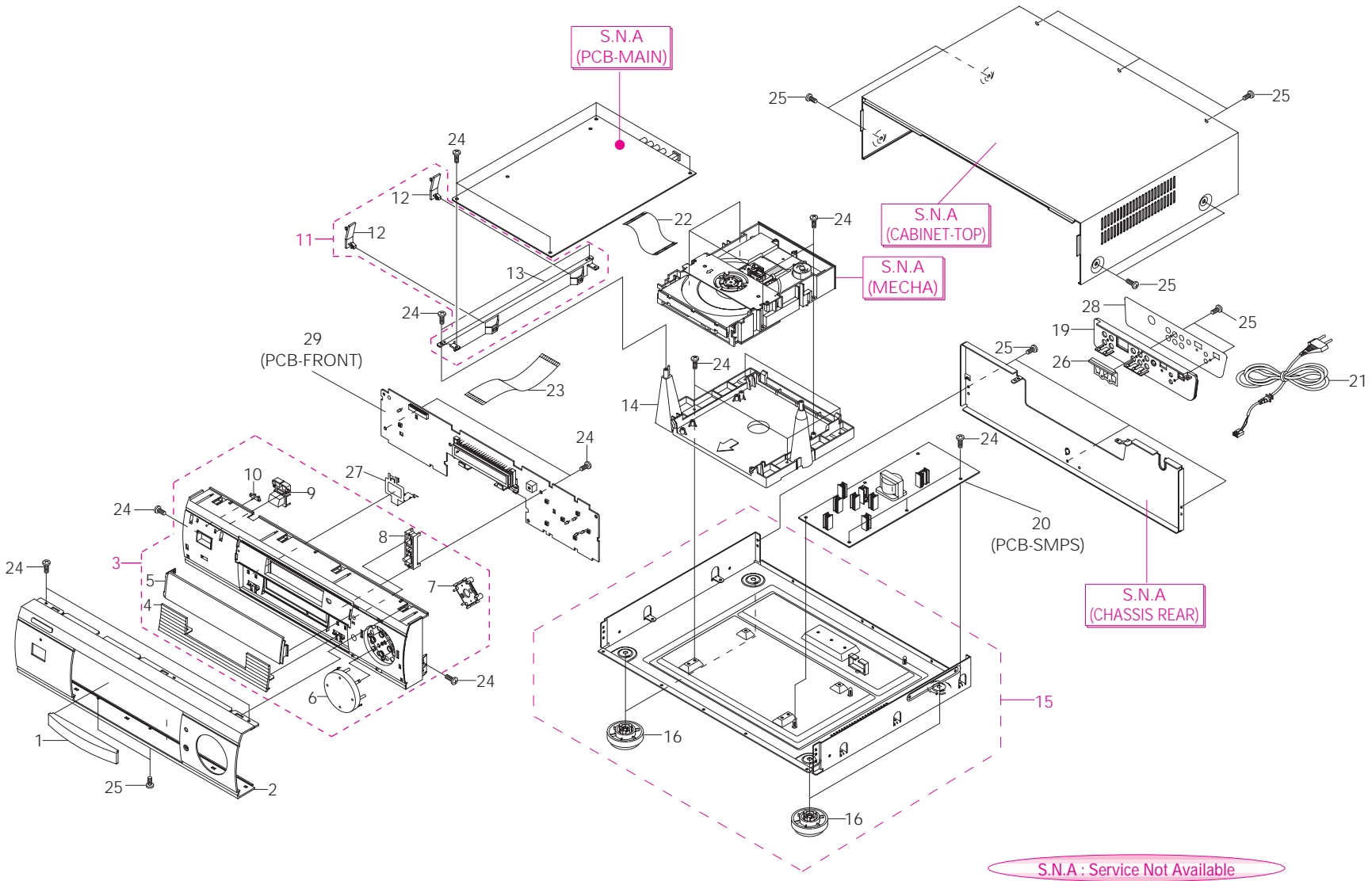

Loc. No	New Part No	Description and Specification	Remark
1	AH95-50295A	ASSY-DOOR;DVD-905,ABS+PBS T0.2,DVD BADGE	
2	AH95-50239E	ASSY-COVER PANEL;DVD905/SEA,AL+BADGE,GOLD BADGE	
3	AH95-10321A	ASSY-CABINET FRONT;DVD-860,ABS,-	
4	AH63-30220A	COVER-CENTER;- ,AL,-,T2.0,TITAN,HAIRLINE,-,D	
5	AH64-40401A	WINDOW-FLT;- ,PMMA,V0,T2.5,VIOLET,-,DVD-86	
6	AH95-50251A	ASSY-KNOB PLAY;DVD-860,ABS,-	
7	AH61-20438A	HOLDER-PLAY;- ,ABS,HB,WHT,-,DVD-860	
8	AH64-11144A	KNOB-OPEN;- ,ABS94,HB,BLK,-,DVD-860	
9	AH64-11143A	KNOB-POWER;- ,ABS94,HB,BLK,-,DVD-860	
10	AH64-40402A	INDICATOR-POWER;- ,PMMA,HB,T2.5,MILK,-,DVD-860	
11	AH95-50238A	ASSY-BRKT PCB;DVD-860K,SECC+NYLON,-	
12	AH61-20279A	HOLDER-PWB;NYLON66,-,-,VIP680T,	
13	AH61-10692A	BRACKET-PCB;- ,SECC,-,T1.0,NTR,-,DVD-860K	
14	AH61-10694A	FRAME-CHASSIS;- ,ABS94,HB,T3,L200,W180,H100,B	
15	AH95-10322A	ASSY-CABINET BOTTOM;DVD-860K,SECC+ABS,-	
16	AH95-50252A	ASSY-FOOT;DVD-860,ABS+EVA SPONGE,-	
19	AH63-30228A	COVER-REAR;- ,ABS94,HB,T2,BLK,-,-,DVD-860	
20	AH90-10725L	ASSY-POWER PCB;DVD760U,SEA	
21	AH39-10002P	POWER CORD;EP2,SPT-1#2/18,2.0M,5239,UL/CSA	
22	3809-001025	CABLE-FLAT;30V,80C,270MM,28P,1.25MM,UL289	
23	3809-001024	CABLE-FLAT;30V,80C,150MM,40P,1.25MM,UL289	
24	6003-000276	SCREW-TAPTITE;BH,+ ,B,M3,L10,ZPC(YEL),SWCH1018AK	
25	6003-000275	SCREW-TAPTITE;BH,+ ,B,M3,L10,BLK ,SWCH1018AK	
26	AH63-40163A	GROUND-REAR;- ,PBS,T0.2,-,DVD-860	
27	AH63-40161A	GROUND-FRONT;- ,PBS,T0.2,-,DVD-860	

## 6-2 Mechanical Parts

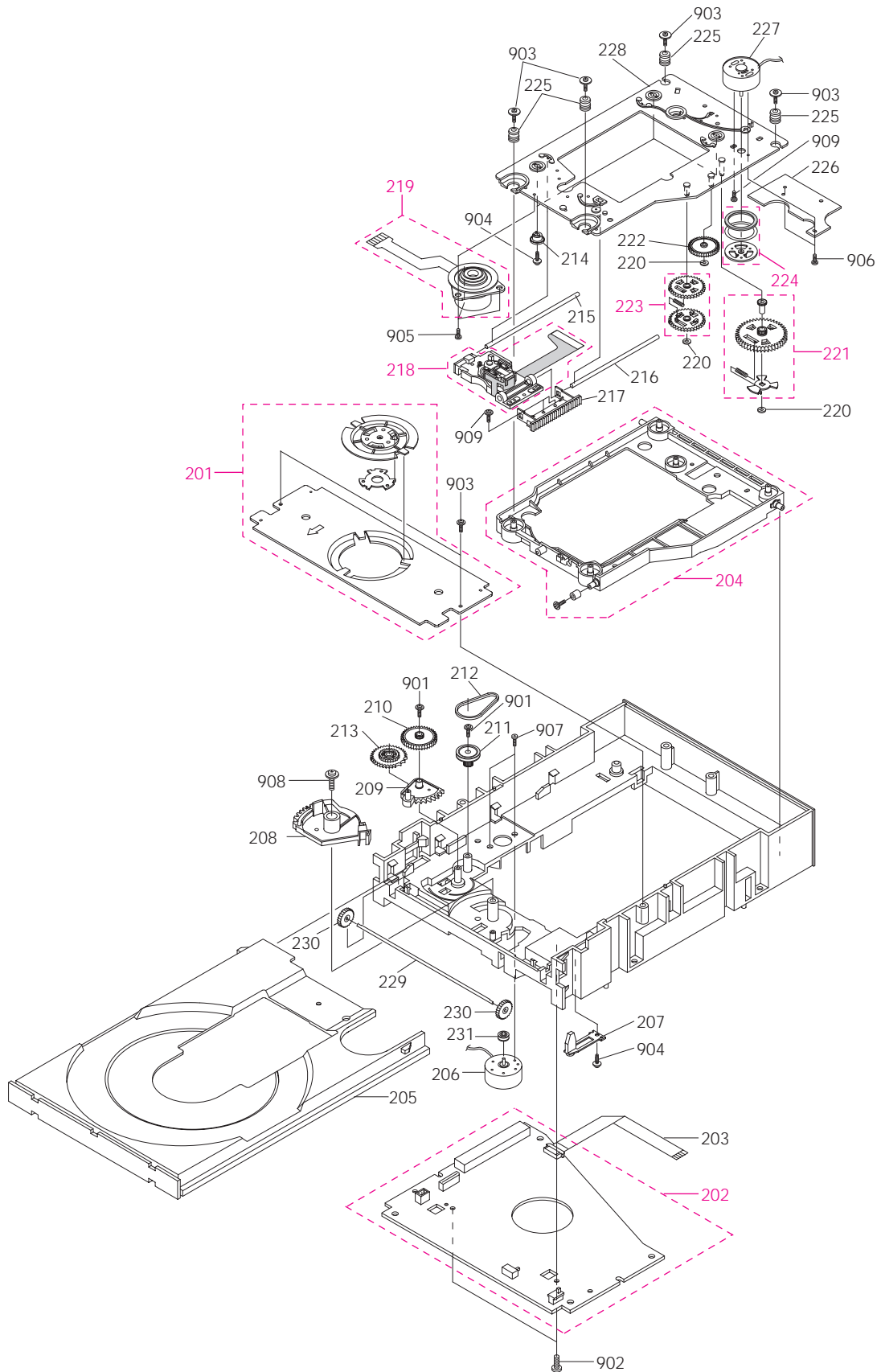

Loc. No	New Part No	Description and Specification	Remark
201	AH91-60117A	ASSY-DECK CLAMPER;DVD860,-,DP-1	
202	AH90-10736C	ASSY-PCB DECK;DP-2, DVD905	
203	3809-001030	CABLE-FLAT;30V,80C,110MM,8P,1MM,UL2896	
204	AH91-60126A	ASSY-CHASSIS SUB;DP-1,DVD860,-	
205	AH66-90054A	TRAY-DVD;DP,ABS,-,BLK,-,DP-1	
206	AH31-10028A	MOTOR-FEED;DP,RF-300C-11440,D/V5.9,60HZ	
207	AH66-30087A	LEVER-OPEN SW;DP,KEPITAL,T0.7,L26,F20-03 BLK	
208	AH66-20194A	GEAR-CAM CENTER;DP,KEPITAL F20-03,M1.2,Z7,BLK,	
209	AH66-20183A	GEAR-CAM SUB;DP,KEPITAL FT2020,M1,2,Z7,-,PC	
210	AH66-20185A	GEAR-TRAY A;DP,KEPITAL F20-03,M0.4/M0.5,Z5	
211	AH66-10024A	PULLEY-GEAR;DP,KEPITAL F20-03,BLK,DP-1	
212	AH66-60033A	BELT-PULLEY;DP,CR,T1.5,0.08,L82.7,BLK,DP-1	
213	AH66-20184A	GEAR-TRAY;DP,KEPITAL F20-03,M0.5/M0.6,Z4	
214	AH61-20424A	HOLDER-CAM;DP,KEPITAL,-,BLK,F20-03,DP-1	
215	AH61-50284A	SHAFT-P.U(L);DP,SUS420J2,OD3,L79,S/FINISHIN	
216	AH61-50278A	SHAFT-P.U(R);DP,SUS420J2,OD3,L87,-,NTR,DP-1	
217	AH66-20178A	RACK-SLIDE;DP,KEPITAL F20-03,WHT,M0.4,P1.	
218	AJ30-20035F	PICK-UP;SOH-D1A	
219	AH91-60127A	ASSY-MOTOR SPINDLE;DP-1,DVD860,-	
220	AH60-30020A	WASHER-PLAIN;DP,-,ID3.1,OD6,T0.3,RED COLOR,	
221	AH91-60120A	ASSY-GEAR-FEED-AU/AL;DP-1,DVD-860,-	
222	AH66-20182A	GEAR-FEED B;DP,KEPITAL F20-03,M0.4,Z44,WHT	
223	AH91-60121A	ASSY-GEAR-FEED-CU/CL;DP-1,DVD-860,-	
224	AH91-60122A	ASSY-GEAR-MAGNET;DP-1,DVD-860,-	
225	AH73-10017A	RUBBER-INSULATOR;RUBBER(LB-40),OD11,DP-1,-	
226	AH90-10694A	ASSY-PCB HALL SENSOR;SDR-130,DOM	
227	AH31-10028A	MOTOR-FEED;DP,RF-300C-11440,D/V5.9,60HZ	
228	AH91-60125A	ASSY-BRKT DECK;DP-1,DVD860,-	
229	AH61-50279A	SHAFT-SYNCRO;DP,SUM24L+ZN,OD2,L119,ZPC,YEL,	
230	AH66-22005A	GEAR-SYNCRO-A;KEPITAL F20-03,M0.8,Z9,-,PCD7.	
231	AH66-10023A	PULLEY-MOTOR;DP,KEPITAL F20-03,BLK,DP-1	
901	AH60-10151A	SCREW-TAP TITE;DP,SPEC6.8 ,PH,+,CP,M2,L5,ZPC	
902	AC60-10051A	SCREW-TAPPING;BH,-,-,M3,L8,FZY	
903	AH60-10143U	SCREW-TAP TITE;DP,PH,+,SPEC,TAP1.7,L5,ZPC	
904	AH60-10145A	SCREW-TAP TITE;DP,PH,+,SPEC OD5.5 FP,TAP1.7,L	
905	AH60-10147A	SCREW-MACHINE;DP,CH,+,FP,M2,L4,ZPC,SWRCH10A,	
906	AH60-10143Q	SCREW-MACHINE;DP,CH,+,FP,M1.7,L4,ZPC,SWRCH10	
907	6001-000012	SCREW-MACHINE;CH,+,M1.7,L2.0,NYLOCK(WHT),SW	
908	AC60-10042A	SCREW-TAPPING;PWH,+,-,M3,L8,-	
909	6001-000002	SCREW-MACHINE;CH,+,M1.7,L3	

## 6-3 Remote Control

---

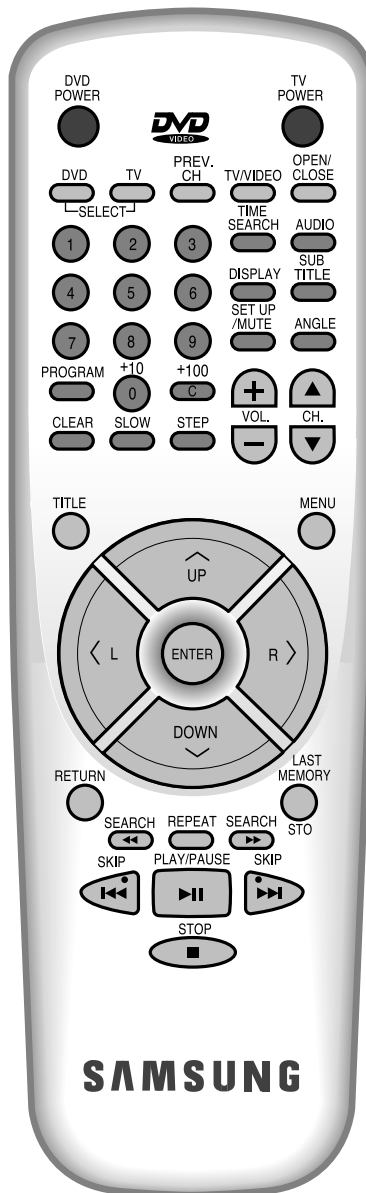

## 7. Electrical Parts List

Loc. No	Part No	Description and Specification	Remark
20	AH90-10725L	ASSY-POWER PCB;DVD760U,SEA	
PC01	⚠ 2305-001021	C-FILM,MPEF;100NF,20%,275V,TP,17.5X7X13.5,	
PC02	⚠ 2305-001021	C-FILM,MPEF;100NF,20%,275V,TP,17.5X7X13.5,	
PC03	⚠ 2201-000916	C-CERAMIC,DISC;100PF,10%,400V,Y5P,TP,10X8,10	
PC04	⚠ 2201-000916	C-CERAMIC,DISC;100PF,10%,400V,Y5P,TP,10X8,10	
PC05	2201-000812	C-CERAMIC,DISC;2.2NF,20%,400V,Y5P,BK,11X7,7.5	
PC06	2201-000812	C-CERAMIC,DISC;2.2NF,20%,400V,Y5P,BK,11X7,7.5	
PC10	⚠ 2401-000342	C-AL;100UF,20%,400V,WT,-,33X30,10MM	
PC11	2301-000140	C-FILM,PEF;10NF,10%,630V,BK,16.5X9.5X5.7X	
PC12	2201-000915	C-CERAMIC,DISC;100PF,10%,1KV,Y5P,TP,6X5,5	
PC13	B1102-0260	C-FILM;CQ 922 M 50V T 102-J ECQB1H102JF3	
PC13A	2301-000289	C-FILM,PEF;5.6NF,5%,50V,TP,6.5X5.5X3.0X5,	
PC14	2301-000129	C-FILM,PEF;100NF,5%,50V,TP,10X9X4.3X5,5MM	
PC15	2401-001919	C-AL;2.2UF,20%,50V,-,TP,4X7MM,5	
PC17	2401-001939	C-AL;22UF,20%,50V,GP,BK,6.3X11MM,2.	
PC18	2301-000415	C-FILM,PEF;22NF,5%,50V,TP,6.5X10.5X4MM,5M	
PC31	2401-001125	C-AL;330UF,20%,25V,WT,TP,10X12.5,5M	
PC32	2401-001125	C-AL;330UF,20%,25V,WT,TP,10X12.5,5M	
PC33	2401-001125	C-AL;330UF,20%,25V,WT,TP,10X12.5,5M	
PC34	2401-001125	C-AL;330UF,20%,25V,WT,TP,10X12.5,5M	
PC36	2401-002162	C-AL;1000UF,20%,25V,GP,TP,10X20,5MM	
PC37	2401-001125	C-AL;330UF,20%,25V,WT,TP,10X12.5,5M	
PC38	2401-001992	C-AL;2200UF,20%,10V,GP,TP,10X20MM,5	
PC39	2401-001125	C-AL;330UF,20%,25V,WT,TP,10X12.5,5M	
PC40	2401-001902	C-AL;100UF,20%,50V,GP,-,6.3X11,2.5	
PC41	2401-001125	C-AL;330UF,20%,25V,WT,TP,10X12.5,5M	
PC42	2301-000129	C-FILM,PEF;100NF,5%,50V,TP,10X9X4.3X5,5MM	
PC43	2301-000129	C-FILM,PEF;100NF,5%,50V,TP,10X9X4.3X5,5MM	
PC45	2301-000129	C-FILM,PEF;100NF,5%,50V,TP,10X9X4.3X5,5MM	
PC46	2401-001507	C-AL;47UF,20%,16V,GP,TP,6.3X5,5	
PC47	2401-001507	C-AL;47UF,20%,16V,GP,TP,6.3X5,5	
PC48	2301-000129	C-FILM,PEF;100NF,5%,50V,TP,10X9X4.3X5,5MM	
PC49	2401-001507	C-AL;47UF,20%,16V,GP,TP,6.3X5,5	
PC50	2301-000129	C-FILM,PEF;100NF,5%,50V,TP,10X9X4.3X5,5MM	
PC51	2401-001507	C-AL;47UF,20%,16V,GP,TP,6.3X5,5	
PC52	2301-000129	C-FILM,PEF;100NF,5%,50V,TP,10X9X4.3X5,5MM	
PC54	2401-002011	C-AL;100UF,20%,25V,GP,TP,6.3X11,5MM	
PCNO1	3711-000190	CONNECTOR-HEADER;1WALL,2P,1R,7.92MM,STRAIGHT,SN	
PCNO2	AH39-20559E	LEAD CONNECTOR-ASSY;-;5264-18,51088-18,18P,350MM	
PD01	⚠ 0402-000103	DIODE-BRIDGE;D2SBA60,600V,1.5A,-	
PD10	0402-000378	DIODE-RECTIFIER;EG01C,1000V,500MA,DO-41	
PD11	0401-000101	DIODE-SWITCHING;1N4148,100V,200MA,500MW,4NS,DO	
PD12	0402-001013	DIODE-RECTIFIER;1SR153-400,400V,800MA,DO-41	
PD31	0402-000383	DIODE-RECTIFIER;S2L20U,200V,1.5A,-	
PD32	0402-000431	DIODE-RECTIFIER;FML-M02S,200V,2.5A,TO-220F	
PD33	0402-000383	DIODE-RECTIFIER;S2L20U,200V,1.5A,-	
PD34	0402-000431	DIODE-RECTIFIER;FML-M02S,200V,2.5A,TO-220F	
PD35	0404-000128	DIODE-SCHOTTKY;FMB-G14L,45V,5A,TO-220F,TP	
PD36	0402-001013	DIODE-RECTIFIER;1SR153-400,400V,800MA,DO-41	

Loc. No	Part No	Description and Specification	Remark
PD37	0402-001013	DIODE-RECTIFIER;1SR153-400,400V,800MA,DO-41	
PD38	0402-001013	DIODE-RECTIFIER;1SR153-400,400V,800MA,DO-41	
PD39	0402-001013	DIODE-RECTIFIER;1SR153-400,400V,800MA,DO-41	
PD42	0402-000127	DIODE-RECTIFIER;1N4002,100V,1A,DO-41	
PF01	▲ 3601-000238	FUSE	
PIC1	1203-000304	IC-PWM CONTROLLER;7552,DIP,8P,-,PLASTIC,30V,-,-,	
PIC2	▲ B4161-0027	PHOTO-COUPLER;PC817XF ST	
PIC3	AC14-12006D	IC;KA431Z,TO-92,TAPING	
PIC4	1203-001083	IC-VOLTAGE REGULATOR;3RF23,TO-202,4P,12.0MIL,PLA	
PIC5	B4008-1134	IC-VOLT REGU;PQ09RF11 SIP	
PIC8	1203-000122	IC-NEGA.FIXED REG.;7908,TO-220,3P,-,PLASTIC,-7.7	
PIC9	1203-000294	IC-POS.FIXED REG.;7808,TO-220,3P,-,PLASTIC,7.7/	
PL02	AC27-92001M	INDUCTOR;70UH-M RT BFS3565R2F,-,-,-,-	
PL11	AC27-92001M	INDUCTOR;70UH-M RT BFS3565R2F,-,-,-,-	
PL31	AC27-92001M	INDUCTOR;70UH-M RT BFS3565R2F,-,-,-,-	
PL32	AC27-92001M	INDUCTOR;70UH-M RT BFS3565R2F,-,-,-,-	
PL33	AC27-92001M	INDUCTOR;70UH-M RT BFS3565R2F,-,-,-,-	
PL34	AC27-92001M	INDUCTOR;70UH-M RT BFS3565R2F,-,-,-,-	
PL35	AC27-92001M	INDUCTOR;70UH-M RT BFS3565R2F,-,-,-,-	
PL36	AC27-12001N	COIL-CHOKE;10UH-15%,RA,K-30,Q80,150KHZ,-,	
PL37	AC27-12001N	COIL-CHOKE;10UH-15%,RA,K-30,Q80,150KHZ,-,	
PLO1	▲ AH29-30010C	FILTER-LINE NOISE;-0.4MH MIN,-,AC250V,FTZ-FILTE	
PLO3	▲ AC29-30050A	FILTER-LINE NOISE;-400UH,-,250V,-	
PQ1	0505-001044	FET-SILICON;SSS3N80,N,800V,1.8A,50HM,35W,T	
PQ2	0504-000118	TR-DIGITAL;KSR1003,NPN,300MW,22K-22K,TO-9	
PQ3	0504-000118	TR-DIGITAL;KSR1003,NPN,300MW,22K-22K,TO-9	
PQ4	0504-001003	TR-DIGITAL;KSR2003,PNP,300MW,22K-22K,TO-9	
PR10	2006-000262	R-CEMENT;2.7OHM,10%,2W,CB,ST,7.5X11X20.	
PR13	2004-000801	R-METAL;33KOHM,5%,1/4W,AA,TP,2.4X6.4MM	
PR14	2004-001167	R-METAL;62KOHM,5%,1/4W,AD,TP,2.4X6.4MM	
PR15	2001-000362	R-CARBON;150OHM,5%,1/8W,AA,TP,1.8X3.2MM	
PR16	2001-000527	R-CARBON;22OHM,5%,1/8W,AA,TP,1.8X3.2MM	
PR17	2003-000273	R-METAL OXIDE;33KOHM,5%,2W,AA,TP,6X16MM	
PR18	2003-000273	R-METAL OXIDE;33KOHM,5%,2W,AA,TP,6X16MM	
PR19	2001-000273	R-CARBON;100KOHM,5%,1/8W,AA,TP,1.8X3.2M	
PR20	▲ 2001-000021	R-CARBON;27OHM,5%,1/4W,AA,TP,2.4X6.4MM	
PR21	2001-000362	R-CARBON;150OHM,5%,1/8W,AA,TP,1.8X3.2MM	
PR22	2001-000281	R-CARBON;100OHM,5%,1/8W,AA,TP,1.8X3.2MM	
PR23	2006-000260	R-CEMENT;0.47OHM,10%,2W,CB,ST,7.5X11X20	
PR24	A1000-0560	R-METAL FILM;RM 1/8 T 512-F	
PR31	2001-000027	R-CARBON;100OHM,5%,1/4W,AA,TP,2.4X6.4MM	
PR32	2001-000105	R-CARBON;1.5KOHM,5%,1/4W,AA,TP,2.4X6.4M	
PR35	2001-000005	R-CARBON;390OHM,5%,1/8W,AA,TP,1.8X3.2MM	
PR36	2001-000221	R-CARBON;1.2KOHM,5%,1/8W,AA,TP,1.8X3.2M	
PR37	2001-000429	R-CARBON;1KOHM,5%,1/8W,AA,TP,1.8X3.2MM	
PR38	2004-000869	R-METAL;3KOHM,1%,1/8W,AA,TP,1.8X3.2MM	
PR39	2004-000459	R-METAL;2.2KOHM,1%,1/8W,AA,TP,1.8X3.2M	
PR40	2003-000148	R-METAL OXIDE;100OHM,5%,2W,AE,TP,6X16MM	
PR41	2001-000780	R-CARBON;470OHM,5%,1/8W,AA,TP,1.8X3.2MM	
PR41A	2001-000780	R-CARBON;470OHM,5%,1/8W,AA,TP,1.8X3.2MM	
PR41B	2001-000780	R-CARBON;470OHM,5%,1/8W,AA,TP,1.8X3.2MM	
PT1	▲ AH26-22001A	TRANS-SWITCHING;110-220V,UL/CSA,ER3530,0.6,ST,	
PVA1	▲ 1405-000186	VARISTOR;470V,4500A,17X12MM,TP	
PZD11	0403-000555	DIODE-ZENER;MTZ30D,30V,29.02-30.51V,500MW,	
PZD12	0403-000539	DIODE-ZENER;MTZ18C,18V,17.42-18.33V,500MW,	

Loc. No	Part No	Description and Specification	Remark
PZD13	0403-000294	DIODE-ZENER;MTZ4.7B,4.7V,4.55-4.80V,500MW,	
-	<b>Do not order</b>	<b>ASSY-PCB MAIN;DVD858V,CHN</b>	<b>S.N.A</b>
AC1	2203-001556	C-CERAMIC,CHIP;100NF,+80-20%,25V,Y5V,TP,1608,	
AC10	2203-001556	C-CERAMIC,CHIP;100NF,+80-20%,25V,Y5V,TP,1608,	
AC11	2203-001556	C-CERAMIC,CHIP;100NF,+80-20%,25V,Y5V,TP,1608,	
AC12	2401-001975	C-AL;47UF,20%,16V,GP,TP,5X11MM,5	
AC13	2203-001556	C-CERAMIC,CHIP;100NF,+80-20%,25V,Y5V,TP,1608,	
AC15	2401-001975	C-AL;47UF,20%,16V,GP,TP,5X11MM,5	
AC16	2401-001975	C-AL;47UF,20%,16V,GP,TP,5X11MM,5	
AC18	2203-001556	C-CERAMIC,CHIP;100NF,+80-20%,25V,Y5V,TP,1608,	
AC19	2401-000419	C-AL;10UF,20%,16V,GP,-,4X7,5	
AC2	2401-001975	C-AL;47UF,20%,16V,GP,TP,5X11MM,5	
AC20	2203-001222	C-CERAMIC,CHIP;820PF,10%,50V,X7R,TP,1608,-	
AC21	2203-001556	C-CERAMIC,CHIP;100NF,+80-20%,25V,Y5V,TP,1608,	
AC22	2401-000419	C-AL;10UF,20%,16V,GP,-,4X7,5	
AC23	2203-001632	C-CERAMIC,CHIP;330PF,5%,50V,CH,TP,1608,1.6MM	
AC24	2203-001559	C-CERAMIC,CHIP;100PF,5%,50V,NPO,TP,1608,1.6MM	
AC26	2203-001556	C-CERAMIC,CHIP;100NF,+80-20%,25V,Y5V,TP,1608,	
AC3	2203-001556	C-CERAMIC,CHIP;100NF,+80-20%,25V,Y5V,TP,1608,	
AC30	2401-000907	C-AL;22UF,20%,16V,GP,-,5X11,2MM	
AC31	2401-001975	C-AL;47UF,20%,16V,GP,TP,5X11MM,5	
AC32	2203-001556	C-CERAMIC,CHIP;100NF,+80-20%,25V,Y5V,TP,1608,	
AC33	2401-001975	C-AL;47UF,20%,16V,GP,TP,5X11MM,5	
AC34	2203-001556	C-CERAMIC,CHIP;100NF,+80-20%,25V,Y5V,TP,1608,	
AC35	2203-001556	C-CERAMIC,CHIP;100NF,+80-20%,25V,Y5V,TP,1608,	
AC36	2203-001222	C-CERAMIC,CHIP;820PF,10%,50V,X7R,TP,1608,-	
AC37	2401-000419	C-AL;10UF,20%,16V,GP,-,4X7,5	
AC38	2203-001556	C-CERAMIC,CHIP;100NF,+80-20%,25V,Y5V,TP,1608,	
AC39	2401-000907	C-AL;22UF,20%,16V,GP,-,5X11,2MM	
AC4	2203-001222	C-CERAMIC,CHIP;820PF,10%,50V,X7R,TP,1608,-	
AC40	2203-001632	C-CERAMIC,CHIP;330PF,5%,50V,CH,TP,1608,1.6MM	
AC41	2203-001559	C-CERAMIC,CHIP;100PF,5%,50V,NPO,TP,1608,1.6MM	
AC42	2203-001556	C-CERAMIC,CHIP;100NF,+80-20%,25V,Y5V,TP,1608,	
AC43	2401-001975	C-AL;47UF,20%,16V,GP,TP,5X11MM,5	
AC44	2203-001556	C-CERAMIC,CHIP;100NF,+80-20%,25V,Y5V,TP,1608,	
AC45	2203-001556	C-CERAMIC,CHIP;100NF,+80-20%,25V,Y5V,TP,1608,	
AC46	2401-001975	C-AL;47UF,20%,16V,GP,TP,5X11MM,5	
AC47	2401-001975	C-AL;47UF,20%,16V,GP,TP,5X11MM,5	
AC48	2203-001556	C-CERAMIC,CHIP;100NF,+80-20%,25V,Y5V,TP,1608,	
AC49	2203-001556	C-CERAMIC,CHIP;100NF,+80-20%,25V,Y5V,TP,1608,	
AC5	2401-000419	C-AL;10UF,20%,16V,GP,-,4X7,5	
AC50	2401-000419	C-AL;10UF,20%,16V,GP,-,4X7,5	
AC51	2203-001222	C-CERAMIC,CHIP;820PF,10%,50V,X7R,TP,1608,-	
AC52	2401-000419	C-AL;10UF,20%,16V,GP,-,4X7,5	
AC53	2401-000907	C-AL;22UF,20%,16V,GP,-,5X11,2MM	
AC54	2203-001632	C-CERAMIC,CHIP;330PF,5%,50V,CH,TP,1608,1.6MM	
AC55	2203-001559	C-CERAMIC,CHIP;100PF,5%,50V,NPO,TP,1608,1.6MM	
AC56	2203-001556	C-CERAMIC,CHIP;100NF,+80-20%,25V,Y5V,TP,1608,	
AC57	2203-001556	C-CERAMIC,CHIP;100NF,+80-20%,25V,Y5V,TP,1608,	
AC58	2203-001556	C-CERAMIC,CHIP;100NF,+80-20%,25V,Y5V,TP,1608,	
AC6	2401-000907	C-AL;22UF,20%,16V,GP,-,5X11,2MM	
AC61	2401-001975	C-AL;47UF,20%,16V,GP,TP,5X11MM,5	
AC62	2203-001556	C-CERAMIC,CHIP;100NF,+80-20%,25V,Y5V,TP,1608,	



Loc. No	Part No	Description and Specification	Remark
AC63	2203-001556	C-CERAMIC,CHIP;100NF,+80-20%,25V,Y5V,TP,1608,	
AC64	2203-001556	C-CERAMIC,CHIP;100NF,+80-20%,25V,Y5V,TP,1608,	
AC65	2401-001975	C-AL;47UF,20%,16V,GP,TP,5X11MM,5	
AC66	2203-001556	C-CERAMIC,CHIP;100NF,+80-20%,25V,Y5V,TP,1608,	
AC67	2203-001222	C-CERAMIC,CHIP;820PF,10%,50V,X7R,TP,1608,-	
AC68	2203-001556	C-CERAMIC,CHIP;100NF,+80-20%,25V,Y5V,TP,1608,	
AC69	2203-001556	C-CERAMIC,CHIP;100NF,+80-20%,25V,Y5V,TP,1608,	
AC7	2203-001556	C-CERAMIC,CHIP;100NF,+80-20%,25V,Y5V,TP,1608,	
AC70	2401-000419	C-AL;10UF,20%,16V,GP,-,4X7,5	
AC71	2401-000907	C-AL;22UF,20%,16V,GP,-,5X11,2MM	
AC72	2401-001975	C-AL;47UF,20%,16V,GP,TP,5X11MM,5	
AC73	2203-001632	C-CERAMIC,CHIP;330PF,5%,50V,CH,TP,1608,1.6MM	
AC74	2203-001559	C-CERAMIC,CHIP;100PF,5%,50V,NPO,TP,1608,1.6MM	
AC75	2203-001556	C-CERAMIC,CHIP;100NF,+80-20%,25V,Y5V,TP,1608,	
AC76	2203-001556	C-CERAMIC,CHIP;100NF,+80-20%,25V,Y5V,TP,1608,	
AC77	2401-001975	C-AL;47UF,20%,16V,GP,TP,5X11MM,5	
AC78	2401-000419	C-AL;10UF,20%,16V,GP,-,4X7,5	
AC79	2203-001556	C-CERAMIC,CHIP;100NF,+80-20%,25V,Y5V,TP,1608,	
AC8	2203-001632	C-CERAMIC,CHIP;330PF,5%,50V,CH,TP,1608,1.6MM	
AC80	2203-001556	C-CERAMIC,CHIP;100NF,+80-20%,25V,Y5V,TP,1608,	
AC81	2401-001975	C-AL;47UF,20%,16V,GP,TP,5X11MM,5	
AC82	2401-001975	C-AL;47UF,20%,16V,GP,TP,5X11MM,5	
AC83	2203-001556	C-CERAMIC,CHIP;100NF,+80-20%,25V,Y5V,TP,1608,	
AC84	2203-001222	C-CERAMIC,CHIP;820PF,10%,50V,X7R,TP,1608,-	
AC85	2401-000907	C-AL;22UF,20%,16V,GP,-,5X11,2MM	
AC86	2401-000419	C-AL;10UF,20%,16V,GP,-,4X7,5	
AC87	2203-001556	C-CERAMIC,CHIP;100NF,+80-20%,25V,Y5V,TP,1608,	
AC88	2203-001632	C-CERAMIC,CHIP;330PF,5%,50V,CH,TP,1608,1.6MM	
AC89	2203-001559	C-CERAMIC,CHIP;100PF,5%,50V,NPO,TP,1608,1.6MM	
AC9	2203-001559	C-CERAMIC,CHIP;100PF,5%,50V,NPO,TP,1608,1.6MM	
AC90	2203-001556	C-CERAMIC,CHIP;100NF,+80-20%,25V,Y5V,TP,1608,	
AC93	2401-001975	C-AL;47UF,20%,16V,GP,TP,5X11MM,5	
AC94	2203-001556	C-CERAMIC,CHIP;100NF,+80-20%,25V,Y5V,TP,1608,	
AC97	2203-001556	C-CERAMIC,CHIP;100NF,+80-20%,25V,Y5V,TP,1608,	
AC98	2203-001556	C-CERAMIC,CHIP;100NF,+80-20%,25V,Y5V,TP,1608,	
AD1	0401-000008	DIODE-SWITCHING;DAN217,80V,100MA,200MW,4NS,SOT	
AD2	0401-000008	DIODE-SWITCHING;DAN217,80V,100MA,200MW,4NS,SOT	
AD3	0401-000008	DIODE-SWITCHING;DAN217,80V,100MA,200MW,4NS,SOT	
AD4	0401-000008	DIODE-SWITCHING;DAN217,80V,100MA,200MW,4NS,SOT	
AIC14	1002-001051	IC-D/A CONVERTER;PCM1723E,16BIT,SOP,24P,204MIL,	
AIC3	1002-001052	IC-D/A CONVERTER;PCM1720E,16BIT,SOP,20P,-,-,ST,	
AIC31	1201-000163	IC-OP AMP;4560,SOP,8P,150MIL,DUAL,100V/M	
AIC32	1201-000163	IC-OP AMP;4560,SOP,8P,150MIL,DUAL,100V/M	
AIC33	1201-000163	IC-OP AMP;4560,SOP,8P,150MIL,DUAL,100V/M	
AIC34	1201-000163	IC-OP AMP;4560,SOP,8P,150MIL,DUAL,100V/M	
AIC36	1201-000163	IC-OP AMP;4560,SOP,8P,150MIL,DUAL,100V/M	
AIC37	1201-000163	IC-OP AMP;4560,SOP,8P,150MIL,DUAL,100V/M	
AIC38	1201-000163	IC-OP AMP;4560,SOP,8P,150MIL,DUAL,100V/M	
AIC39	1201-000163	IC-OP AMP;4560,SOP,8P,150MIL,DUAL,100V/M	
AIC40	1201-000163	IC-OP AMP;4560,SOP,8P,150MIL,DUAL,100V/M	
AIC41	1201-000163	IC-OP AMP;4560,SOP,8P,150MIL,DUAL,100V/M	
AIC42	1201-000163	IC-OP AMP;4560,SOP,8P,150MIL,DUAL,100V/M	
AIC43	1201-000163	IC-OP AMP;4560,SOP,8P,150MIL,DUAL,100V/M	
AIC44	1201-000163	IC-OP AMP;4560,SOP,8P,150MIL,DUAL,100V/M	
AIC47	AH14-10004T	IC-ANALOG M/PLEXER;MC14053BD,SOP,TAPE 16P ANALOG	

Loc. No	Part No	Description and Specification	Remark
AIC9	1002-001052	IC-D/A CONVERTER;PCM1720E,16BIT,SOP,20P,-,-,ST,	
AL1	3301-000319	CORE-FERRITE BEAD;AB,2.0X1.25X0.9MM,1000,3000G	
AL10	2901-001025	FILTER-EMI SMD;25V,200MA,-,-,3.2X1.6X1.8,TP	
AL11	3301-000319	CORE-FERRITE BEAD;AB,2.0X1.25X0.9MM,1000,3000G	
AL12	3301-000319	CORE-FERRITE BEAD;AB,2.0X1.25X0.9MM,1000,3000G	
AL13	3301-000319	CORE-FERRITE BEAD;AB,2.0X1.25X0.9MM,1000,3000G	
AL14	3301-000319	CORE-FERRITE BEAD;AB,2.0X1.25X0.9MM,1000,3000G	
AL15	2901-001025	FILTER-EMI SMD;25V,200MA,-,-,3.2X1.6X1.8,TP	
AL16	3301-000319	CORE-FERRITE BEAD;AB,2.0X1.25X0.9MM,1000,3000G	
AL17	3301-000319	CORE-FERRITE BEAD;AB,2.0X1.25X0.9MM,1000,3000G	
AL18	3301-000319	CORE-FERRITE BEAD;AB,2.0X1.25X0.9MM,1000,3000G	
AL19	3301-000319	CORE-FERRITE BEAD;AB,2.0X1.25X0.9MM,1000,3000G	
AL2	3301-000319	CORE-FERRITE BEAD;AB,2.0X1.25X0.9MM,1000,3000G	
AL20	2901-001025	FILTER-EMI SMD;25V,200MA,-,-,3.2X1.6X1.8,TP	
AL21	3301-000325	CORE-FERRITE BEAD;AB,3.2X2.5X1.3MM,-,-	
AL22	3301-000319	CORE-FERRITE BEAD;AB,2.0X1.25X0.9MM,1000,3000G	
AL23	3301-000319	CORE-FERRITE BEAD;AB,2.0X1.25X0.9MM,1000,3000G	
AL24	2901-001025	FILTER-EMI SMD;25V,200MA,-,-,3.2X1.6X1.8,TP	
AL25	3301-000319	CORE-FERRITE BEAD;AB,2.0X1.25X0.9MM,1000,3000G	
AL26	3301-000319	CORE-FERRITE BEAD;AB,2.0X1.25X0.9MM,1000,3000G	
AL27	3301-000319	CORE-FERRITE BEAD;AB,2.0X1.25X0.9MM,1000,3000G	
AL28	2901-001025	FILTER-EMI SMD;25V,200MA,-,-,3.2X1.6X1.8,TP	
AL29	3301-000319	CORE-FERRITE BEAD;AB,2.0X1.25X0.9MM,1000,3000G	
AL3	2901-001025	FILTER-EMI SMD;25V,200MA,-,-,3.2X1.6X1.8,TP	
AL30	3301-000319	CORE-FERRITE BEAD;AB,2.0X1.25X0.9MM,1000,3000G	
AL31	3301-000319	CORE-FERRITE BEAD;AB,2.0X1.25X0.9MM,1000,3000G	
AL32	3301-000319	CORE-FERRITE BEAD;AB,2.0X1.25X0.9MM,1000,3000G	
AL33	2901-001025	FILTER-EMI SMD;25V,200MA,-,-,3.2X1.6X1.8,TP	
AL34	3301-000319	CORE-FERRITE BEAD;AB,2.0X1.25X0.9MM,1000,3000G	
AL35	3301-000319	CORE-FERRITE BEAD;AB,2.0X1.25X0.9MM,1000,3000G	
AL36	2901-001025	FILTER-EMI SMD;25V,200MA,-,-,3.2X1.6X1.8,TP	
AL37	2901-001025	FILTER-EMI SMD;25V,200MA,-,-,3.2X1.6X1.8,TP	
AL38	3301-000319	CORE-FERRITE BEAD;AB,2.0X1.25X0.9MM,1000,3000G	
AL39	3301-000319	CORE-FERRITE BEAD;AB,2.0X1.25X0.9MM,1000,3000G	
AL4	3301-000319	CORE-FERRITE BEAD;AB,2.0X1.25X0.9MM,1000,3000G	
AL40	3301-000319	CORE-FERRITE BEAD;AB,2.0X1.25X0.9MM,1000,3000G	
AL5	3301-000319	CORE-FERRITE BEAD;AB,2.0X1.25X0.9MM,1000,3000G	
AL51	2007-000029	R-CHIP;0OHM,5%,1/10W,DA,TP,2012	
AL52	2007-000029	R-CHIP;0OHM,5%,1/10W,DA,TP,2012	
AL7	3301-000319	CORE-FERRITE BEAD;AB,2.0X1.25X0.9MM,1000,3000G	
AL8	3301-000319	CORE-FERRITE BEAD;AB,2.0X1.25X0.9MM,1000,3000G	
AQ1	0501-000341	TR-SMALL SIGNAL;KSC1623-L,NPN,200MW,SOT-23,TP,	
AQ10	0501-000341	TR-SMALL SIGNAL;KSC1623-L,NPN,200MW,SOT-23,TP,	
AQ11	0501-000341	TR-SMALL SIGNAL;KSC1623-L,NPN,200MW,SOT-23,TP,	
AQ12	0501-000314	TR-SMALL SIGNAL;KSA812,PNP,150MW,SOT-23,TP,90-	
AQ13	0501-000341	TR-SMALL SIGNAL;KSC1623-L,NPN,200MW,SOT-23,TP,	
AQ14	0501-000341	TR-SMALL SIGNAL;KSC1623-L,NPN,200MW,SOT-23,TP,	
AQ15	0504-000156	TR-DIGITAL;KSR2103,PNP,200MW,22K-22K,SOT-	
AQ16	0501-000341	TR-SMALL SIGNAL;KSC1623-L,NPN,200MW,SOT-23,TP,	
AQ17	0501-000341	TR-SMALL SIGNAL;KSC1623-L,NPN,200MW,SOT-23,TP,	
AQ18	0504-000128	TR-DIGITAL;-NPN,200MW,22K-22KOHM,SOT-23,	
AQ2	0501-000341	TR-SMALL SIGNAL;KSC1623-L,NPN,200MW,SOT-23,TP,	
AQ3	0501-000341	TR-SMALL SIGNAL;KSC1623-L,NPN,200MW,SOT-23,TP,	
AQ4	0501-000341	TR-SMALL SIGNAL;KSC1623-L,NPN,200MW,SOT-23,TP,	
AQ7	0501-000341	TR-SMALL SIGNAL;KSC1623-L,NPN,200MW,SOT-23,TP,	

Loc. No	Part No	Description and Specification	Remark
AQ8	0501-000341	TR-SMALL SIGNAL;KSC1623-L,NPN,200MW,SOT-23,TP,	
AQ9	0501-000341	TR-SMALL SIGNAL;KSC1623-L,NPN,200MW,SOT-23,TP,	
AR1	2007-000090	R-CHIP;10KOHM,5%,1/16W,DA,TP,1608	
AR101	2007-000074	R-CHIP;100OHM,5%,1/16W,DA,TP,1608	
AR102	2007-000074	R-CHIP;100OHM,5%,1/16W,DA,TP,1608	
AR103	2007-000074	R-CHIP;100OHM,5%,1/16W,DA,TP,1608	
AR104	2007-000074	R-CHIP;100OHM,5%,1/16W,DA,TP,1608	
AR105	2007-000074	R-CHIP;100OHM,5%,1/16W,DA,TP,1608	
AR107	2007-000070	R-CHIP;0OHM,5%,1/16W,DA,TP,1608	
AR11	2007-000090	R-CHIP;10KOHM,5%,1/16W,DA,TP,1608	
AR110	2007-000074	R-CHIP;100OHM,5%,1/16W,DA,TP,1608	
AR12	2007-000102	R-CHIP;100KOHM,5%,1/16W,DA,TP,1608	
AR14	2007-000078	R-CHIP;1KOHM,5%,1/16W,DA,TP,1608	
AR15	2007-000078	R-CHIP;1KOHM,5%,1/16W,DA,TP,1608	
AR16	2007-000539	R-CHIP;200OHM,5%,1/16W,DA,TP,1608	
AR17	2007-000090	R-CHIP;10KOHM,5%,1/16W,DA,TP,1608	
AR18	2007-000090	R-CHIP;10KOHM,5%,1/16W,DA,TP,1608	
AR19	2007-000090	R-CHIP;10KOHM,5%,1/16W,DA,TP,1608	
AR2	2007-000090	R-CHIP;10KOHM,5%,1/16W,DA,TP,1608	
AR20	2007-000078	R-CHIP;1KOHM,5%,1/16W,DA,TP,1608	
AR21	2007-000090	R-CHIP;10KOHM,5%,1/16W,DA,TP,1608	
AR22	2007-000102	R-CHIP;100KOHM,5%,1/16W,DA,TP,1608	
AR23	2007-000090	R-CHIP;10KOHM,5%,1/16W,DA,TP,1608	
AR25	2007-000078	R-CHIP;1KOHM,5%,1/16W,DA,TP,1608	
AR26	2007-000078	R-CHIP;1KOHM,5%,1/16W,DA,TP,1608	
AR29	2007-001240	R-CHIP;910OHM,5%,1/16W,DA,TP,1608	
AR3	2007-000090	R-CHIP;10KOHM,5%,1/16W,DA,TP,1608	
AR30	2007-000074	R-CHIP;100OHM,5%,1/16W,DA,TP,1608	
AR32	2007-000090	R-CHIP;10KOHM,5%,1/16W,DA,TP,1608	
AR33	2007-000102	R-CHIP;100KOHM,5%,1/16W,DA,TP,1608	
AR38	2007-000090	R-CHIP;10KOHM,5%,1/16W,DA,TP,1608	
AR39	2007-000090	R-CHIP;10KOHM,5%,1/16W,DA,TP,1608	
AR4	2007-000090	R-CHIP;10KOHM,5%,1/16W,DA,TP,1608	
AR40	2007-000090	R-CHIP;10KOHM,5%,1/16W,DA,TP,1608	
AR41	2007-000090	R-CHIP;10KOHM,5%,1/16W,DA,TP,1608	
AR42	2007-000078	R-CHIP;1KOHM,5%,1/16W,DA,TP,1608	
AR43	2007-000102	R-CHIP;100KOHM,5%,1/16W,DA,TP,1608	
AR44	2007-001240	R-CHIP;910OHM,5%,1/16W,DA,TP,1608	
AR45	2007-000074	R-CHIP;100OHM,5%,1/16W,DA,TP,1608	
AR46	2007-000090	R-CHIP;10KOHM,5%,1/16W,DA,TP,1608	
AR47	2007-000102	R-CHIP;100KOHM,5%,1/16W,DA,TP,1608	
AR48	2007-000091	R-CHIP;12KOHM,5%,1/16W,DA,TP,1608	
AR49	2007-000078	R-CHIP;1KOHM,5%,1/16W,DA,TP,1608	
AR5	2007-001240	R-CHIP;910OHM,5%,1/16W,DA,TP,1608	
AR50	2007-000078	R-CHIP;1KOHM,5%,1/16W,DA,TP,1608	
AR51	2007-000539	R-CHIP;200OHM,5%,1/16W,DA,TP,1608	
AR52	2007-000090	R-CHIP;10KOHM,5%,1/16W,DA,TP,1608	
AR53	2007-000078	R-CHIP;1KOHM,5%,1/16W,DA,TP,1608	
AR54	2007-000078	R-CHIP;1KOHM,5%,1/16W,DA,TP,1608	
AR55	2007-000090	R-CHIP;10KOHM,5%,1/16W,DA,TP,1608	
AR56	2007-000090	R-CHIP;10KOHM,5%,1/16W,DA,TP,1608	
AR57	2007-000090	R-CHIP;10KOHM,5%,1/16W,DA,TP,1608	
AR58	2007-000078	R-CHIP;1KOHM,5%,1/16W,DA,TP,1608	
AR59	2007-001240	R-CHIP;910OHM,5%,1/16W,DA,TP,1608	
AR6	2007-000074	R-CHIP;100OHM,5%,1/16W,DA,TP,1608	

Loc. No	Part No	Description and Specification	Remark
AR60	2007-000074	R-CHIP;100OHM,5%,1/16W,DA,TP,1608	
AR61	2007-000090	R-CHIP;10KOHM,5%,1/16W,DA,TP,1608	
AR62	2007-000102	R-CHIP;100KOHM,5%,1/16W,DA,TP,1608	
AR64	2007-000091	R-CHIP;12KOHM,5%,1/16W,DA,TP,1608	
AR65	2007-000102	R-CHIP;100KOHM,5%,1/16W,DA,TP,1608	
AR67	2007-000076	R-CHIP;330OHM,5%,1/16W,DA,TP,1608	
AR68	2007-000075	R-CHIP;220OHM,5%,1/16W,DA,TP,1608	
AR69	2007-000074	R-CHIP;100OHM,5%,1/16W,DA,TP,1608	
AR7	2007-000078	R-CHIP;1KOHM,5%,1/16W,DA,TP,1608	
AR70	2007-000090	R-CHIP;10KOHM,5%,1/16W,DA,TP,1608	
AR71	2007-000090	R-CHIP;10KOHM,5%,1/16W,DA,TP,1608	
AR72	2007-000090	R-CHIP;10KOHM,5%,1/16W,DA,TP,1608	
AR73	2007-000090	R-CHIP;10KOHM,5%,1/16W,DA,TP,1608	
AR74	2007-001240	R-CHIP;910OHM,5%,1/16W,DA,TP,1608	
AR75	2007-000074	R-CHIP;100OHM,5%,1/16W,DA,TP,1608	
AR76	2007-000078	R-CHIP;1KOHM,5%,1/16W,DA,TP,1608	
AR77	2007-000090	R-CHIP;10KOHM,5%,1/16W,DA,TP,1608	
AR78	2007-000102	R-CHIP;100KOHM,5%,1/16W,DA,TP,1608	
AR79	2007-000091	R-CHIP;12KOHM,5%,1/16W,DA,TP,1608	
AR8	2007-000090	R-CHIP;10KOHM,5%,1/16W,DA,TP,1608	
AR80	2007-000102	R-CHIP;100KOHM,5%,1/16W,DA,TP,1608	
AR81	2007-000078	R-CHIP;1KOHM,5%,1/16W,DA,TP,1608	
AR82	2007-000078	R-CHIP;1KOHM,5%,1/16W,DA,TP,1608	
AR83	2007-000090	R-CHIP;10KOHM,5%,1/16W,DA,TP,1608	
AR84	2007-000078	R-CHIP;1KOHM,5%,1/16W,DA,TP,1608	
AR85	2007-000078	R-CHIP;1KOHM,5%,1/16W,DA,TP,1608	
AR86	2007-001240	R-CHIP;910OHM,5%,1/16W,DA,TP,1608	
AR87	2007-000074	R-CHIP;100OHM,5%,1/16W,DA,TP,1608	
AR88	2007-000090	R-CHIP;10KOHM,5%,1/16W,DA,TP,1608	
AR89	2007-000090	R-CHIP;10KOHM,5%,1/16W,DA,TP,1608	
AR9	2007-000102	R-CHIP;100KOHM,5%,1/16W,DA,TP,1608	
AR90	2007-000090	R-CHIP;10KOHM,5%,1/16W,DA,TP,1608	
AR91	2007-000090	R-CHIP;10KOHM,5%,1/16W,DA,TP,1608	
AR92	2007-000708	R-CHIP;3.9KOHM,1%,1/16W,DA,TP,1608	
AR93	2007-000102	R-CHIP;100KOHM,5%,1/16W,DA,TP,1608	
AR94	2007-000102	R-CHIP;100KOHM,5%,1/16W,DA,TP,1608	
AR95	2007-000074	R-CHIP;100OHM,5%,1/16W,DA,TP,1608	
AR96	2007-000078	R-CHIP;1KOHM,5%,1/16W,DA,TP,1608	
AR98	2007-000074	R-CHIP;100OHM,5%,1/16W,DA,TP,1608	
AR99	2007-000074	R-CHIP;100OHM,5%,1/16W,DA,TP,1608	
C101	2203-001559	C-CERAMIC,CHIP;100PF,5%,50V,NPO,TP,1608,1.6MM	
C11	2203-001556	C-CERAMIC,CHIP;100NF,+80-20%,25V,Y5V,TP,1608,	
C12	2203-001556	C-CERAMIC,CHIP;100NF,+80-20%,25V,Y5V,TP,1608,	
C17	2401-000907	C-AL;22UF,20%,16V,GP,-,5X11,2MM	
C22	2203-001556	C-CERAMIC,CHIP;100NF,+80-20%,25V,Y5V,TP,1608,	
C23	2203-001556	C-CERAMIC,CHIP;100NF,+80-20%,25V,Y5V,TP,1608,	
C25	2401-000907	C-AL;22UF,20%,16V,GP,-,5X11,2MM	
C29	2401-000907	C-AL;22UF,20%,16V,GP,-,5X11,2MM	
C3	2401-000907	C-AL;22UF,20%,16V,GP,-,5X11,2MM	
C30	2203-001556	C-CERAMIC,CHIP;100NF,+80-20%,25V,Y5V,TP,1608,	
C31	2203-001556	C-CERAMIC,CHIP;100NF,+80-20%,25V,Y5V,TP,1608,	
C35	2401-000907	C-AL;22UF,20%,16V,GP,-,5X11,2MM	
C36	2203-001034	C-CERAMIC,CHIP;5.6NF,10%,50V,X7R,1608,-,TP	
C38	2203-001034	C-CERAMIC,CHIP;5.6NF,10%,50V,X7R,1608,-,TP	
C39	2203-001034	C-CERAMIC,CHIP;5.6NF,10%,50V,X7R,1608,-,TP	

Loc. No	Part No	Description and Specification	Remark
C40	2203-001556	C-CERAMIC,CHIP;100NF,+80-20%,25V,Y5V,TP,1608,	
C42	2203-005012	C-CERAMIC,CHIP;150NF,20%,16V,Y5V,TP,1608,-	
C43	2401-000907	C-AL;22UF,20%,16V,GP,-,5X11,2MM	
C46	2203-001556	C-CERAMIC,CHIP;100NF,+80-20%,25V,Y5V,TP,1608,	
C48	2203-001556	C-CERAMIC,CHIP;100NF,+80-20%,25V,Y5V,TP,1608,	
C6	2401-000907	C-AL;22UF,20%,16V,GP,-,5X11,2MM	
CN1	3708-001085	CONNECTOR-FPC/FC/PIC;40P,1.25MM,STRAIGHT,SN	
D101	0401-000008	DIODE-SWITCHING;DAN217,80V,100MA,200MW,4NS,SOT	
DA1	0401-000008	DIODE-SWITCHING;DAN217,80V,100MA,200MW,4NS,SOT	
DA2	0401-000008	DIODE-SWITCHING;DAN217,80V,100MA,200MW,4NS,SOT	
DA3	0401-000008	DIODE-SWITCHING;DAN217,80V,100MA,200MW,4NS,SOT	
DA4	0401-000008	DIODE-SWITCHING;DAN217,80V,100MA,200MW,4NS,SOT	
DA5	0401-000008	DIODE-SWITCHING;DAN217,80V,100MA,200MW,4NS,SOT	
DC1	2203-001556	C-CERAMIC,CHIP;100NF,+80-20%,25V,Y5V,TP,1608,	
DC10	2203-000308	C-CERAMIC,CHIP;120PF,5%,50V,NPO,TP,1608,-	
DC100	2203-001556	C-CERAMIC,CHIP;100NF,+80-20%,25V,Y5V,TP,1608,	
DC11	2203-001556	C-CERAMIC,CHIP;100NF,+80-20%,25V,Y5V,TP,1608,	
DC12	2203-000257	C-CERAMIC,CHIP;10NF,10%,50V,X7R,TP,1608,-	
DC13	2203-001556	C-CERAMIC,CHIP;100NF,+80-20%,25V,Y5V,TP,1608,	
DC14	2203-001556	C-CERAMIC,CHIP;100NF,+80-20%,25V,Y5V,TP,1608,	
DC15	2203-001556	C-CERAMIC,CHIP;100NF,+80-20%,25V,Y5V,TP,1608,	
DC17	2203-001556	C-CERAMIC,CHIP;100NF,+80-20%,25V,Y5V,TP,1608,	
DC18	2203-001556	C-CERAMIC,CHIP;100NF,+80-20%,25V,Y5V,TP,1608,	
DC18D	2203-001556	C-CERAMIC,CHIP;100NF,+80-20%,25V,Y5V,TP,1608,	
DC19	2401-001895	C-AL;100UF,20%,16V,GP,BK,6.3X11MM,2	
DC2	2203-001556	C-CERAMIC,CHIP;100NF,+80-20%,25V,Y5V,TP,1608,	
DC20	2203-001556	C-CERAMIC,CHIP;100NF,+80-20%,25V,Y5V,TP,1608,	
DC21	2203-001556	C-CERAMIC,CHIP;100NF,+80-20%,25V,Y5V,TP,1608,	
DC22	2203-001556	C-CERAMIC,CHIP;100NF,+80-20%,25V,Y5V,TP,1608,	
DC23	2401-001975	C-AL;47UF,20%,16V,GP,TP,5X11MM,5	
DC24	2203-001556	C-CERAMIC,CHIP;100NF,+80-20%,25V,Y5V,TP,1608,	
DC25	2203-001556	C-CERAMIC,CHIP;100NF,+80-20%,25V,Y5V,TP,1608,	
DC26	2401-001975	C-AL;47UF,20%,16V,GP,TP,5X11MM,5	
DC27	2203-001556	C-CERAMIC,CHIP;100NF,+80-20%,25V,Y5V,TP,1608,	
DC28	2203-001556	C-CERAMIC,CHIP;100NF,+80-20%,25V,Y5V,TP,1608,	
DC29	2203-005083	C-CERAMIC,CHIP;220NF,10%,50V,X7R,TP,1608,-	
DC30	2203-005083	C-CERAMIC,CHIP;220NF,10%,50V,X7R,TP,1608,-	
DC31	2203-001556	C-CERAMIC,CHIP;100NF,+80-20%,25V,Y5V,TP,1608,	
DC32	2203-001636	C-CERAMIC,CHIP;33PF,5%,50V,NPO,TP,1608,1.6MM	
DC35	2203-001556	C-CERAMIC,CHIP;100NF,+80-20%,25V,Y5V,TP,1608,	
DC36	2203-001556	C-CERAMIC,CHIP;100NF,+80-20%,25V,Y5V,TP,1608,	
DC37	2203-001556	C-CERAMIC,CHIP;100NF,+80-20%,25V,Y5V,TP,1608,	
DC38	2203-001556	C-CERAMIC,CHIP;100NF,+80-20%,25V,Y5V,TP,1608,	
DC39	2203-001556	C-CERAMIC,CHIP;100NF,+80-20%,25V,Y5V,TP,1608,	
DC40	2203-001556	C-CERAMIC,CHIP;100NF,+80-20%,25V,Y5V,TP,1608,	
DC41	2203-001556	C-CERAMIC,CHIP;100NF,+80-20%,25V,Y5V,TP,1608,	
DC42	2203-001556	C-CERAMIC,CHIP;100NF,+80-20%,25V,Y5V,TP,1608,	
DC43	2203-001556	C-CERAMIC,CHIP;100NF,+80-20%,25V,Y5V,TP,1608,	
DC44	2203-001556	C-CERAMIC,CHIP;100NF,+80-20%,25V,Y5V,TP,1608,	
DC47	2203-000384	C-CERAMIC,CHIP;15PF,5%,50V,NPO,TP,1608,-	
DC48	2203-000384	C-CERAMIC,CHIP;15PF,5%,50V,NPO,TP,1608,-	
DC49	2203-001559	C-CERAMIC,CHIP;100PF,5%,50V,NPO,TP,1608,1.6MM	
DC5	2203-001556	C-CERAMIC,CHIP;100NF,+80-20%,25V,Y5V,TP,1608,	
DC50	2203-001556	C-CERAMIC,CHIP;100NF,+80-20%,25V,Y5V,TP,1608,	
DC51	2203-001636	C-CERAMIC,CHIP;33PF,5%,50V,NPO,TP,1608,1.6MM	

Loc. No	Part No	Description and Specification	Remark
DC52	2203-001636	C-CERAMIC,CHIP;33PF,5%,50V,NPO,TP,1608,1.6MM	
DC530	2203-000426	C-CERAMIC,CHIP;18PF,5%,50V,NPO,TP,1608,-	
DC54	2401-001975	C-AL;47UF,20%,16V,GP,TP,5X11MM,5	
DC55	2203-001556	C-CERAMIC,CHIP;100NF,+80-20%,25V,Y5V,TP,1608,	
DC56	2203-001636	C-CERAMIC,CHIP;33PF,5%,50V,NPO,TP,1608,1.6MM	
DC57	2203-000384	C-CERAMIC,CHIP;15PF,5%,50V,NPO,TP,1608,-	
DC58	2203-001556	C-CERAMIC,CHIP;100NF,+80-20%,25V,Y5V,TP,1608,	
DC59	2203-001556	C-CERAMIC,CHIP;100NF,+80-20%,25V,Y5V,TP,1608,	
DC6	2203-001632	C-CERAMIC,CHIP;330PF,5%,50V,CH,TP,1608,1.6MM	
DC60	2203-001556	C-CERAMIC,CHIP;100NF,+80-20%,25V,Y5V,TP,1608,	
DC61	2203-001632	C-CERAMIC,CHIP;330PF,5%,50V,CH,TP,1608,1.6MM	
DC62	2203-001556	C-CERAMIC,CHIP;100NF,+80-20%,25V,Y5V,TP,1608,	
DC7	2203-001632	C-CERAMIC,CHIP;330PF,5%,50V,CH,TP,1608,1.6MM	
DC8	2203-001397	C-CERAMIC,CHIP;2.2NF,5%,50V,COG,1608,-,TP	
DC9	2203-001634	C-CERAMIC,CHIP;33NF,10%,50V,X7R,TP,1608,1.6MM	
DD1	0405-000106	DIODE-VARACTOR;1SV228,15V,10NA,SOT-23,TP	
DIC1	AH13-10030F	IC-ASIC;-,TC90A19F,QFP,100,DATA PROC.I	
DIC10	0801-000885	IC-CMOS LOGIC;7S04,INVERTER,SOP,5P,150MIL,SI	
DIC11	0801-002166	IC-CMOS LOGIC;7SHU04,INVERTER GATE,SOP,5P,6.	
DIC12	0801-002166	IC-CMOS LOGIC;7SHU04,INVERTER GATE,SOP,5P,6.	
DIC13	0801-002096	IC-CMOS LOGIC;7SH08,AND GATE,SOP,5P,110MIL,S	
DIC2	1105-001038	IC-DRAM;48C512,512KX8BIT,SOJ,28P,400MI	
DIC3	0801-002166	IC-CMOS LOGIC;7SHU04,INVERTER GATE,SOP,5P,6.	
DIC6	AH13-10030L	IC-ASIC;-,TC6804AF,QFP,80P,COPY RPOTEC	
DIC7	0801-000885	IC-CMOS LOGIC;7S04,INVERTER,SOP,5P,150MIL,SI	
DIC8	1201-000211	IC-OP AMP;272A,SOP,8P,150MIL,DUAL,7.5V/M	
DIC9	0801-002115	IC-CMOS LOGIC;7SH04F,INVERTER,SOP,5P,49.2MIL	
DL1	2007-000029	R-CHIP;0OHM,5%,1/10W,DA,TP,2012	
DL2	3301-000319	CORE-FERRITE BEAD;AB,2.0X1.25X0.9MM,1000,3000G	
DL3	3301-000319	CORE-FERRITE BEAD;AB,2.0X1.25X0.9MM,1000,3000G	
DL4	2703-000401	INDUCTOR-SMD;1UH,10%,3.2X2.5X2.2MM	
DL5	3301-000319	CORE-FERRITE BEAD;AB,2.0X1.25X0.9MM,1000,3000G	
DL6	3301-000319	CORE-FERRITE BEAD;AB,2.0X1.25X0.9MM,1000,3000G	
DL7	3301-000319	CORE-FERRITE BEAD;AB,2.0X1.25X0.9MM,1000,3000G	
DL8	3301-000319	CORE-FERRITE BEAD;AB,2.0X1.25X0.9MM,1000,3000G	
DL9	3301-000319	CORE-FERRITE BEAD;AB,2.0X1.25X0.9MM,1000,3000G	
DQ1	0501-000199	TR-SMALL SIGNAL;2SC2714-Y,NPN,100MW,SOT-23,TP,	
DR1	2007-000090	R-CHIP;10KOHM,5%,1/16W,DA,TP,1608	
DR10	2007-000090	R-CHIP;10KOHM,5%,1/16W,DA,TP,1608	
DR100	2007-000402	R-CHIP;150OHM,5%,1/16W,DA,TP,1608	
DR101	2007-000729	R-CHIP;300OHM,5%,1/16W,DA,TP,1608	
DR102	2007-000074	R-CHIP;100OHM,5%,1/16W,DA,TP,1608	
DR103	2007-000074	R-CHIP;100OHM,5%,1/16W,DA,TP,1608	
DR104	2007-000074	R-CHIP;100OHM,5%,1/16W,DA,TP,1608	
DR105	2007-000074	R-CHIP;100OHM,5%,1/16W,DA,TP,1608	
DR11	2007-000090	R-CHIP;10KOHM,5%,1/16W,DA,TP,1608	
DR12	2007-000090	R-CHIP;10KOHM,5%,1/16W,DA,TP,1608	
DR2	2007-000077	R-CHIP;470OHM,5%,1/16W,DA,TP,1608	
DR24	2007-000074	R-CHIP;100OHM,5%,1/16W,DA,TP,1608	
DR25	2007-000074	R-CHIP;100OHM,5%,1/16W,DA,TP,1608	
DR27	2007-000074	R-CHIP;100OHM,5%,1/16W,DA,TP,1608	
DR28	2007-000084	R-CHIP;4.7KOHM,5%,1/16W,DA,TP,1608	
DR29	2007-000072	R-CHIP;47OHM,5%,1/16W,DA,TP,1608	
DR3	2007-000092	R-CHIP;15KOHM,5%,1/16W,DA,TP,1608	
DR30	2007-000078	R-CHIP;1KOHM,5%,1/16W,DA,TP,1608	

## Electrical Parts List

Loc. No	Part No	Description and Specification	Remark
DR35	2007-000120	R-CHIP;680OHM,5%,1/16W,DA,TP,1608	
DR36	2007-000084	R-CHIP;4.7KOHM,5%,1/16W,DA,TP,1608	
DR37	2007-000127	R-CHIP;9.1KOHM,5%,1/16W,DA,TP,1608	
DR39	2007-000084	R-CHIP;4.7KOHM,5%,1/16W,DA,TP,1608	
DR4	2007-000077	R-CHIP;470OHM,5%,1/16W,DA,TP,1608	
DR40	2007-000129	R-CHIP;27KOHM,5%,1/16W,DA,TP,1608	
DR41	2007-000134	R-CHIP;33KOHM,5%,1/16W,DA,TP,1608	
DR42	2007-000079	R-CHIP;1.8KOHM,5%,1/16W,DA,TP,1608	
DR43	2007-000109	R-CHIP;1MOHM,5%,1/16W,DA,TP,1608	
DR45	2007-000078	R-CHIP;1KOHM,5%,1/16W,DA,TP,1608	
DR46	2007-000074	R-CHIP;100OHM,5%,1/16W,DA,TP,1608	
DR47	2007-000109	R-CHIP;1MOHM,5%,1/16W,DA,TP,1608	
DR48	2007-000113	R-CHIP;33OHM,5%,1/16W,DA,TP,1608	
DR49	2007-000113	R-CHIP;33OHM,5%,1/16W,DA,TP,1608	
DR5	2007-000127	R-CHIP;9.1KOHM,5%,1/16W,DA,TP,1608	
DR50	2007-000120	R-CHIP;680OHM,5%,1/16W,DA,TP,1608	
DR6	2007-000070	R-CHIP;0OHM,5%,1/16W,DA,TP,1608	
DR7	2007-000082	R-CHIP;3.3KOHM,5%,1/16W,DA,TP,1608	
DR8	2007-000081	R-CHIP;2.7KOHM,5%,1/16W,DA,TP,1608	
DR9	2007-000078	R-CHIP;1KOHM,5%,1/16W,DA,TP,1608	
DY1	2801-003255	CRYSTAL-UNIT;33MHZ,20PPM,28-AAA,16PF,30OHM,	
DY2	2801-003348	CRYSTAL-UNIT;27MHZ,20PPM,28-AAM,20PF,20OHM,	
F-CABI	3809-001025	CABLE-FLAT;30V,80C,270MM,28P,1.25MM,UL289	
FLAT-C	3809-001024	CABLE-FLAT;30V,80C,150MM,40P,1.25MM,UL289	
KC25	2203-001556	C-CERAMIC,CHIP;100NF,+80-20%,25V,Y5V,TP,1608,	
KC26	2203-001556	C-CERAMIC,CHIP;100NF,+80-20%,25V,Y5V,TP,1608,	
KC27	2401-000419	C-AL;10UF,20%,16V,GP,-,4X7,5	
KC28	2203-001556	C-CERAMIC,CHIP;100NF,+80-20%,25V,Y5V,TP,1608,	
KC29	2401-001912	C-AL;1UF,20%,50V,GP,BK,5X11MM,2MM	
KC30	2401-001912	C-AL;1UF,20%,50V,GP,BK,5X11MM,2MM	
KC31	2203-001556	C-CERAMIC,CHIP;100NF,+80-20%,25V,Y5V,TP,1608,	
KC32	2203-000888	C-CERAMIC,CHIP;4.7NF,10%,50V,X7R,TP,1608,-	
KC33	2401-000419	C-AL;10UF,20%,16V,GP,-,4X7,5	
KC34	2203-001556	C-CERAMIC,CHIP;100NF,+80-20%,25V,Y5V,TP,1608,	
KC35	2401-002180	C-AL;2.2UF,20%,50V,GP,TP,5X11,5MM	
KC37	2401-001912	C-AL;1UF,20%,50V,GP,BK,5X11MM,2MM	
KC39	2203-001703	C-CERAMIC,CHIP;560PF,10%,50V,X7R,TP,1608,-	
KC40	2203-000140	C-CERAMIC,CHIP;1.5NF,10%,50V,X7R,1608,-,TP	
KC41	2203-000888	C-CERAMIC,CHIP;4.7NF,10%,50V,X7R,TP,1608,-	
KC42	2401-000419	C-AL;10UF,20%,16V,GP,-,4X7,5	
KC43	2203-001556	C-CERAMIC,CHIP;100NF,+80-20%,25V,Y5V,TP,1608,	
KC44	2401-000419	C-AL;10UF,20%,16V,GP,-,4X7,5	
KC45	2203-001556	C-CERAMIC,CHIP;100NF,+80-20%,25V,Y5V,TP,1608,	
KC46	2401-002180	C-AL;2.2UF,20%,50V,GP,TP,5X11,5MM	
KC48	2401-001912	C-AL;1UF,20%,50V,GP,BK,5X11MM,2MM	
KC50	2203-001703	C-CERAMIC,CHIP;560PF,10%,50V,X7R,TP,1608,-	
KC51	2203-000140	C-CERAMIC,CHIP;1.5NF,10%,50V,X7R,1608,-,TP	
KC52	2401-000419	C-AL;10UF,20%,16V,GP,-,4X7,5	
KC53	2203-001556	C-CERAMIC,CHIP;100NF,+80-20%,25V,Y5V,TP,1608,	
KD10	0401-000008	DIODE-SWITCHING;DAN217,80V,100MA,200MW,4NS,SOT	
KIC3	1002-000169	IC-D/A CONVERTER;PCM1710U,16BIT,SOP,28P,-,-,ST,	
KIC4	1201-000163	IC-OP AMP;4560,SOP,8P,150MIL,DUAL,100V/M	
KIC5	AH14-10004T	IC-ANALOG M/PLEXER;MC14053BD,SOP,TAPE 16P ANALOG	
KL3	3301-000319	CORE-FERRITE BEAD;AB,2.0X1.25X0.9MM,1000,3000G	
KL4	3301-000319	CORE-FERRITE BEAD;AB,2.0X1.25X0.9MM,1000,3000G	

Loc. No	Part No	Description and Specification	Remark
KL5	3301-000319	CORE-FERRITE BEAD;AB,2.0X1.25X0.9MM,1000,3000G	
KL6	2007-000029	R-CHIP;0OHM,5%,1/16W,DA,TP,2012	
KR31A	2007-000074	R-CHIP;100OHM,5%,1/16W,DA,TP,1608	
KR35	2007-000078	R-CHIP;1KOHM,5%,1/16W,DA,TP,1608	
KR39	2007-001240	R-CHIP;910OHM,5%,1/16W,DA,TP,1608	
KR40	2007-001240	R-CHIP;910OHM,5%,1/16W,DA,TP,1608	
KR41	2007-001240	R-CHIP;910OHM,5%,1/16W,DA,TP,1608	
KR42	2007-000078	R-CHIP;1KOHM,5%,1/16W,DA,TP,1608	
KR44	2007-000084	R-CHIP;4.7KOHM,5%,1/16W,DA,TP,1608	
KR45	2007-000078	R-CHIP;1KOHM,5%,1/16W,DA,TP,1608	
KR48	2007-001240	R-CHIP;910OHM,5%,1/16W,DA,TP,1608	
KR49	2007-001240	R-CHIP;910OHM,5%,1/16W,DA,TP,1608	
KR50	2007-001240	R-CHIP;910OHM,5%,1/16W,DA,TP,1608	
KR51	2007-000078	R-CHIP;1KOHM,5%,1/16W,DA,TP,1608	
KR53	2007-000084	R-CHIP;4.7KOHM,5%,1/16W,DA,TP,1608	
KR75	2007-000070	R-CHIP;0OHM,5%,1/16W,DA,TP,1608	
KR76	2007-000074	R-CHIP;100OHM,5%,1/16W,DA,TP,1608	
KR77	2007-000074	R-CHIP;100OHM,5%,1/16W,DA,TP,1608	
KR78	2007-000074	R-CHIP;100OHM,5%,1/16W,DA,TP,1608	
KR80	2007-000070	R-CHIP;0OHM,5%,1/16W,DA,TP,1608	
KR82	2007-000078	R-CHIP;1KOHM,5%,1/16W,DA,TP,1608	
L101	3301-000325	CORE-FERRITE BEAD;AB,3.2X2.5X1.3MM,-,-	
L4	3301-000319	CORE-FERRITE BEAD;AB,2.0X1.25X0.9MM,1000,3000G	
L6	3301-000319	CORE-FERRITE BEAD;AB,2.0X1.25X0.9MM,1000,3000G	
LC1	2203-001554	C-CERAMIC,CHIP;1.8NF,10%,50V,X7R,TP,1608,-	
LC11	2203-001556	C-CERAMIC,CHIP;100NF,+80-20%,25V,Y5V,TP,1608,	
LC12	2203-001556	C-CERAMIC,CHIP;100NF,+80-20%,25V,Y5V,TP,1608,	
LC2	2203-001703	C-CERAMIC,CHIP;560PF,10%,50V,X7R,TP,1608,-	
LC5	2203-001556	C-CERAMIC,CHIP;100NF,+80-20%,25V,Y5V,TP,1608,	
LC6	2203-001556	C-CERAMIC,CHIP;100NF,+80-20%,25V,Y5V,TP,1608,	
LC7	2203-001556	C-CERAMIC,CHIP;100NF,+80-20%,25V,Y5V,TP,1608,	
LC8	2203-001556	C-CERAMIC,CHIP;100NF,+80-20%,25V,Y5V,TP,1608,	
LC9	2203-001556	C-CERAMIC,CHIP;100NF,+80-20%,25V,Y5V,TP,1608,	
LIC1	0801-002146	IC-CMOS LOGIC;7S86,X-OR GATE,SOP,5P,63MIL,SI	
LIC2	0801-002146	IC-CMOS LOGIC;7S86,X-OR GATE,SOP,5P,63MIL,SI	
LIC3	1202-000143	IC-VOLTAGE COMP.;75S393,SOP,5P,-,SINGLE,0V,-,PL	
LIC4	1201-000163	IC-OP AMP;4560,SOP,8P,150MIL,DUAL,100V/M	
LIC6	0801-002145	IC-CMOS LOGIC;7W74F,D FLIP-FLOP,SOP,8P,110MI	
LIC7	0801-002143	IC-CMOS LOGIC;7S32,OR GATE,SOP,5P,49.3MIL,SI	
LIC8	0801-002144	IC-CMOS LOGIC;7W04F,INVERTER,SOP,8P,122MIL,T	
LR1	2007-000090	R-CHIP;10KOHM,5%,1/16W,DA,TP,1608	
LR10	2007-000078	R-CHIP;1KOHM,5%,1/16W,DA,TP,1608	
LR11	2007-000078	R-CHIP;1KOHM,5%,1/16W,DA,TP,1608	
LR12	2007-000098	R-CHIP;56KOHM,5%,1/16W,DA,TP,1608	
LR14	2007-000078	R-CHIP;1KOHM,5%,1/16W,DA,TP,1608	
LR16	2007-000965	R-CHIP;5.1KOHM,5%,1/16W,DA,TP,1608	
LR17	2007-000078	R-CHIP;1KOHM,5%,1/16W,DA,TP,1608	
LR2	2007-000098	R-CHIP;56KOHM,5%,1/16W,DA,TP,1608	
LR3	2007-000094	R-CHIP;22KOHM,5%,1/16W,DA,TP,1608	
LR4	2007-000098	R-CHIP;56KOHM,5%,1/16W,DA,TP,1608	
LR5	2007-000082	R-CHIP;3.3KOHM,5%,1/16W,DA,TP,1608	
LR6	2007-000082	R-CHIP;3.3KOHM,5%,1/16W,DA,TP,1608	
LR7	2007-000123	R-CHIP;1.5KOHM,5%,1/16W,DA,TP,1608	
LR8	2007-000259	R-CHIP;1.6KOHM,5%,1/16W,DA,TP,1608	
LR9	2007-000078	R-CHIP;1KOHM,5%,1/16W,DA,TP,1608	



Loc. No	Part No	Description and Specification	Remark
MC1	2203-001588	C-CERAMIC,CHIP;18PF,5%,50V,CH,TP,1608,1.6MM	
MC10	2203-001556	C-CERAMIC,CHIP;100NF,+80-20%,25V,Y5V,TP,1608,	
MC11	2203-001556	C-CERAMIC,CHIP;100NF,+80-20%,25V,Y5V,TP,1608,	
MC12	2203-001556	C-CERAMIC,CHIP;100NF,+80-20%,25V,Y5V,TP,1608,	
MC13	2203-001556	C-CERAMIC,CHIP;100NF,+80-20%,25V,Y5V,TP,1608,	
MC14	2203-001559	C-CERAMIC,CHIP;100PF,5%,50V,NPO,TP,1608,1.6MM	
MC15	2203-001556	C-CERAMIC,CHIP;100NF,+80-20%,25V,Y5V,TP,1608,	
MC16	2203-001556	C-CERAMIC,CHIP;100NF,+80-20%,25V,Y5V,TP,1608,	
MC18	2203-001556	C-CERAMIC,CHIP;100NF,+80-20%,25V,Y5V,TP,1608,	
MC19	2203-001556	C-CERAMIC,CHIP;100NF,+80-20%,25V,Y5V,TP,1608,	
MC2	2203-001588	C-CERAMIC,CHIP;18PF,5%,50V,CH,TP,1608,1.6MM	
MC3	2203-001556	C-CERAMIC,CHIP;100NF,+80-20%,25V,Y5V,TP,1608,	
MC4	2203-001556	C-CERAMIC,CHIP;100NF,+80-20%,25V,Y5V,TP,1608,	
MC5	2203-001556	C-CERAMIC,CHIP;100NF,+80-20%,25V,Y5V,TP,1608,	
MC6	2203-001556	C-CERAMIC,CHIP;100NF,+80-20%,25V,Y5V,TP,1608,	
MC7	2203-001556	C-CERAMIC,CHIP;100NF,+80-20%,25V,Y5V,TP,1608,	
MC9	2203-001556	C-CERAMIC,CHIP;100NF,+80-20%,25V,Y5V,TP,1608,	
MIC1	0903-001031	IC-MICROCONTROLLER;93CS41,8BIT,FLAT,100P,-,20MHZ	
MIC3	1106-000401	IC-SRAM;681000,128KX8BIT,SOP,32P,525MI	
MIC4	0801-002207	IC-CMOS LOGIC;74AC573,LATCH,SOP,20P,300MIL,O	
MIC5	1103-001048	IC-EEPROM;24C02,256X8BIT,SOP,8P,150MIL,3	
MIC6	0801-000379	IC-CMOS LOGIC;74HC00,NAND GATE,SOP,14P,150MI	
MIC8	0801-000885	IC-CMOS LOGIC;7S04,INVERTER,SOP,5P,150MIL,SI	
MJP1	2007-000070	R-CHIP;0OHM,5%,1/16W,DA,TP,1608	
MJP20	2007-000070	R-CHIP;0OHM,5%,1/16W,DA,TP,1608	
MJP21	2007-000070	R-CHIP;0OHM,5%,1/16W,DA,TP,1608	
MJP24	2007-000070	R-CHIP;0OHM,5%,1/16W,DA,TP,1608	
MJP25	2007-000070	R-CHIP;0OHM,5%,1/16W,DA,TP,1608	
MJP4	2007-000070	R-CHIP;0OHM,5%,1/16W,DA,TP,1608	
MPL1	3301-000319	CORE-FERRITE BEAD;AB,2.0X1.25X0.9MM,1000,3000G	
MPL2	3301-000319	CORE-FERRITE BEAD;AB,2.0X1.25X0.9MM,1000,3000G	
MPL3	2007-000029	R-CHIP;0OHM,5%,1/10W,DA,TP,2012	
MPL4	2007-000029	R-CHIP;0OHM,5%,1/10W,DA,TP,2012	
MPL5	2007-000029	R-CHIP;0OHM,5%,1/10W,DA,TP,2012	
MR1	2007-000084	R-CHIP;4.7KOHM,5%,1/16W,DA,TP,1608	
MR10	2007-000084	R-CHIP;4.7KOHM,5%,1/16W,DA,TP,1608	
MR11	2007-000109	R-CHIP;1MOHM,5%,1/16W,DA,TP,1608	
MR12	2007-000084	R-CHIP;4.7KOHM,5%,1/16W,DA,TP,1608	
MR13	2007-000078	R-CHIP;1KOHM,5%,1/16W,DA,TP,1608	
MR15	2007-000124	R-CHIP;2.2KOHM,5%,1/16W,DA,TP,1608	
MR18	2007-000076	R-CHIP;330OHM,5%,1/16W,DA,TP,1608	
MR19	2007-000084	R-CHIP;4.7KOHM,5%,1/16W,DA,TP,1608	
MR2	2007-000084	R-CHIP;4.7KOHM,5%,1/16W,DA,TP,1608	
MR20	2007-000084	R-CHIP;4.7KOHM,5%,1/16W,DA,TP,1608	
MR21	2007-000074	R-CHIP;100OHM,5%,1/16W,DA,TP,1608	
MR22	2007-000074	R-CHIP;100OHM,5%,1/16W,DA,TP,1608	
MR23	2007-000074	R-CHIP;100OHM,5%,1/16W,DA,TP,1608	
MR24	2007-000074	R-CHIP;100OHM,5%,1/16W,DA,TP,1608	
MR25	2007-000074	R-CHIP;100OHM,5%,1/16W,DA,TP,1608	
MR26	2007-000074	R-CHIP;100OHM,5%,1/16W,DA,TP,1608	
MR27	2007-000074	R-CHIP;100OHM,5%,1/16W,DA,TP,1608	
MR28	2007-000074	R-CHIP;100OHM,5%,1/16W,DA,TP,1608	
MR3	2007-000084	R-CHIP;4.7KOHM,5%,1/16W,DA,TP,1608	
MR31	2007-000074	R-CHIP;100OHM,5%,1/16W,DA,TP,1608	
MR32	2007-000074	R-CHIP;100OHM,5%,1/16W,DA,TP,1608	

Loc. No	Part No	Description and Specification	Remark
MR33	2007-000074	R-CHIP;100OHM,5%,1/16W,DA,TP,1608	
MR34	2007-000074	R-CHIP;100OHM,5%,1/16W,DA,TP,1608	
MR35	2007-000074	R-CHIP;100OHM,5%,1/16W,DA,TP,1608	
MR36	2007-000074	R-CHIP;100OHM,5%,1/16W,DA,TP,1608	
MR37	2007-000074	R-CHIP;100OHM,5%,1/16W,DA,TP,1608	
MR38	2007-000074	R-CHIP;100OHM,5%,1/16W,DA,TP,1608	
MR39	2007-000074	R-CHIP;100OHM,5%,1/16W,DA,TP,1608	
MR4	2007-000084	R-CHIP;4.7KOHM,5%,1/16W,DA,TP,1608	
MR40	2007-000074	R-CHIP;100OHM,5%,1/16W,DA,TP,1608	
MR41	2007-000078	R-CHIP;1KOHM,5%,1/16W,DA,TP,1608	
MR42	2007-000074	R-CHIP;100OHM,5%,1/16W,DA,TP,1608	
MR43	2007-000078	R-CHIP;1KOHM,5%,1/16W,DA,TP,1608	
MR44	2007-000078	R-CHIP;1KOHM,5%,1/16W,DA,TP,1608	
MR45	2007-000074	R-CHIP;100OHM,5%,1/16W,DA,TP,1608	
MR46	2007-000084	R-CHIP;4.7KOHM,5%,1/16W,DA,TP,1608	
MR5	2007-000084	R-CHIP;4.7KOHM,5%,1/16W,DA,TP,1608	
MR6	2007-000084	R-CHIP;4.7KOHM,5%,1/16W,DA,TP,1608	
MR7	2007-000084	R-CHIP;4.7KOHM,5%,1/16W,DA,TP,1608	
MR8	2007-000084	R-CHIP;4.7KOHM,5%,1/16W,DA,TP,1608	
MR9	2007-000084	R-CHIP;4.7KOHM,5%,1/16W,DA,TP,1608	
MS1	3704-000472	SOCKET-IC;32P,DIP,SN,2.54MM	
MS2	3704-000272	SOCKET-IC;40P,DIP,SN,2.54MM	
MY1	2801-000199	CRYSTAL-UNIT;20MHZ,50PPM,28-AAA,16PF,50OHM,	
OPT-JA	3707-001005	CONNECTOR-OPTICAL;PLUG,SM,-,4.4/2.0MM	
PC1	2401-001895	C-AL;100UF,20%,16V,GP,BK,6.3X11MM,2	
PC10	2203-001556	C-CERAMIC,CHIP;100NF,+80-20%,25V,Y5V,TP,1608,	
PC2	2203-001556	C-CERAMIC,CHIP;100NF,+80-20%,25V,Y5V,TP,1608,	
PC3	2401-001895	C-AL;100UF,20%,16V,GP,BK,6.3X11MM,2	
PC4	2203-001556	C-CERAMIC,CHIP;100NF,+80-20%,25V,Y5V,TP,1608,	
PC5	2401-001895	C-AL;100UF,20%,16V,GP,BK,6.3X11MM,2	
PC6	2203-001556	C-CERAMIC,CHIP;100NF,+80-20%,25V,Y5V,TP,1608,	
PC7	2401-001895	C-AL;100UF,20%,16V,GP,BK,6.3X11MM,2	
PC8	2203-001556	C-CERAMIC,CHIP;100NF,+80-20%,25V,Y5V,TP,1608,	
PC9	2401-001895	C-AL;100UF,20%,16V,GP,BK,6.3X11MM,2	
PCN1	3711-000736	CONNECTOR-HEADER;BOX,18P,1R,2.5MM,BLACK,BRASS	
Q1	0501-002082	TR-SMALL SIGNAL;HN1C01F,NPN,300MV,SC-74,TP,120	
Q101	0501-000314	TR-SMALL SIGNAL;KSA812,PNP,150MW,SOT-23,TP,90-	
Q102	0501-000341	TR-SMALL SIGNAL;KSC1623-L,NPN,200MW,SOT-23,TP,	
Q103	0501-000341	TR-SMALL SIGNAL;KSC1623-L,NPN,200MW,SOT-23,TP,	
Q104	0501-000314	TR-SMALL SIGNAL;KSA812,PNP,150MW,SOT-23,TP,90-	
Q2	0504-000126	TR-DIGITAL;KSR1101,NPN,200MW,4.7K-4.7K,SO	
R1	2007-000091	R-CHIP;12KOHM,5%,1/16W,DA,TP,1608	
R101	2007-000090	R-CHIP;10KOHM,5%,1/16W,DA,TP,1608	
R102	2007-000078	R-CHIP;1KOHM,5%,1/16W,DA,TP,1608	
R103	2007-000074	R-CHIP;100OHM,5%,1/16W,DA,TP,1608	
R104	2007-000074	R-CHIP;100OHM,5%,1/16W,DA,TP,1608	
R105	2007-000074	R-CHIP;100OHM,5%,1/16W,DA,TP,1608	
R14	2007-000090	R-CHIP;10KOHM,5%,1/16W,DA,TP,1608	
R18	2007-000458	R-CHIP;18KOHM,5%,1/16W,DA,TP,1608	
R22	2007-000096	R-CHIP;30KOHM,5%,1/16W,DA,TP,1608	
R24	2007-000096	R-CHIP;30KOHM,5%,1/16W,DA,TP,1608	
R27	2007-000458	R-CHIP;18KOHM,5%,1/16W,DA,TP,1608	
R29	2007-000092	R-CHIP;15KOHM,5%,1/16W,DA,TP,1608	
R31	2007-000096	R-CHIP;30KOHM,5%,1/16W,DA,TP,1608	
R33	2007-000096	R-CHIP;30KOHM,5%,1/16W,DA,TP,1608	

Loc. No	Part No	Description and Specification	Remark
R38	2007-000458	R-CHIP:18KOHM,5%,1/16W,DA,TP,1608	
R40	2007-000092	R-CHIP:15KOHM,5%,1/16W,DA,TP,1608	
R41	2007-000096	R-CHIP:30KOHM,5%,1/16W,DA,TP,1608	
R42	2007-000096	R-CHIP:30KOHM,5%,1/16W,DA,TP,1608	
R43	2007-000081	R-CHIP:2.7KOHM,5%,1/16W,DA,TP,1608	
R44	2007-000078	R-CHIP:1KOHM,5%,1/16W,DA,TP,1608	
R45	2007-000092	R-CHIP:15KOHM,5%,1/16W,DA,TP,1608	
R46	2007-000078	R-CHIP:1KOHM,5%,1/16W,DA,TP,1608	
R48	2007-000122	R-CHIP:1.2KOHM,5%,1/16W,DA,TP,1608	
R49	2007-000708	R-CHIP:3.9KOHM,1%,1/16W,DA,TP,1608	
R50	2007-000078	R-CHIP:1KOHM,5%,1/16W,DA,TP,1608	
R51	2007-000088	R-CHIP:7.5KOHM,5%,1/16W,DA,TP,1608	
R52	2007-000094	R-CHIP:22KOHM,5%,1/16W,DA,TP,1608	
R54	2007-000078	R-CHIP:1KOHM,5%,1/16W,DA,TP,1608	
R55	2007-000102	R-CHIP:100KOHM,5%,1/16W,DA,TP,1608	
R57	2007-000078	R-CHIP:1KOHM,5%,1/16W,DA,TP,1608	
R60	2007-000078	R-CHIP:1KOHM,5%,1/16W,DA,TP,1608	
R61	2007-000092	R-CHIP:15KOHM,5%,1/16W,DA,TP,1608	
R7	2007-000090	R-CHIP:10KOHM,5%,1/16W,DA,TP,1608	
RC1	2401-001975	C-AL;47UF,20%,16V,GP,TP,5X11MM,5	
RC10	2203-001556	C-CERAMIC,CHIP:100NF,+80-20%,25V,Y5V,TP,1608,	
RC11	2203-001556	C-CERAMIC,CHIP:100NF,+80-20%,25V,Y5V,TP,1608,	
RC12	2203-001556	C-CERAMIC,CHIP:100NF,+80-20%,25V,Y5V,TP,1608,	
RC12A	2203-001556	C-CERAMIC,CHIP:100NF,+80-20%,25V,Y5V,TP,1608,	
RC13	2203-001697	C-CERAMIC,CHIP:82PF,5%,50V,CH,TP,1608,1.6MM	
RC13A	2401-001022	C-AL;3.3UF,20%,50V,GP,-,5X11,2MM	
RC14	2203-001556	C-CERAMIC,CHIP:100NF,+80-20%,25V,Y5V,TP,1608,	
RC15	2203-001556	C-CERAMIC,CHIP:100NF,+80-20%,25V,Y5V,TP,1608,	
RC16	2203-001556	C-CERAMIC,CHIP:100NF,+80-20%,25V,Y5V,TP,1608,	
RC17	2401-001975	C-AL;47UF,20%,16V,GP,TP,5X11MM,5	
RC18	2203-001556	C-CERAMIC,CHIP:100NF,+80-20%,25V,Y5V,TP,1608,	
RC19	2203-000308	C-CERAMIC,CHIP:120PF,5%,50V,NPO,TP,1608,-	
RC2	2203-001556	C-CERAMIC,CHIP:100NF,+80-20%,25V,Y5V,TP,1608,	
RC20	2203-001556	C-CERAMIC,CHIP:100NF,+80-20%,25V,Y5V,TP,1608,	
RC21	2203-001556	C-CERAMIC,CHIP:100NF,+80-20%,25V,Y5V,TP,1608,	
RC21A	2401-000419	C-AL;10UF,20%,16V,GP,-,4X7,5	
RC22	2203-001556	C-CERAMIC,CHIP:100NF,+80-20%,25V,Y5V,TP,1608,	
RC22A	2203-001556	C-CERAMIC,CHIP:100NF,+80-20%,25V,Y5V,TP,1608,	
RC23	2203-001556	C-CERAMIC,CHIP:100NF,+80-20%,25V,Y5V,TP,1608,	
RC24	2203-001556	C-CERAMIC,CHIP:100NF,+80-20%,25V,Y5V,TP,1608,	
RC24A	2401-000419	C-AL;10UF,20%,16V,GP,-,4X7,5	
RC25	2203-001585	C-CERAMIC,CHIP:180PF,5%,50V,CH,TP,1608,1.6MM	
RC26	2401-000419	C-AL;10UF,20%,16V,GP,-,4X7,5	
RC27	2203-001559	C-CERAMIC,CHIP:100PF,5%,50V,NPO,TP,1608,1.6MM	
RC28	2203-001559	C-CERAMIC,CHIP:100PF,5%,50V,NPO,TP,1608,1.6MM	
RC29	2203-000440	C-CERAMIC,CHIP:1NF,10%,50V,X7R,TP,1608,-	
RC2A	2203-001556	C-CERAMIC,CHIP:100NF,+80-20%,25V,Y5V,TP,1608,	
RC3	2401-000907	C-AL;22UF,20%,16V,GP,-,5X11,2MM	
RC30A	2203-001556	C-CERAMIC,CHIP:100NF,+80-20%,25V,Y5V,TP,1608,	
RC30C	2203-001556	C-CERAMIC,CHIP:100NF,+80-20%,25V,Y5V,TP,1608,	
RC31	2401-001975	C-AL;47UF,20%,16V,GP,TP,5X11MM,5	
RC32	2203-001556	C-CERAMIC,CHIP:100NF,+80-20%,25V,Y5V,TP,1608,	
RC33	2401-001975	C-AL;47UF,20%,16V,GP,TP,5X11MM,5	
RC34	2401-001975	C-AL;47UF,20%,16V,GP,TP,5X11MM,5	
RC35	2203-001556	C-CERAMIC,CHIP:100NF,+80-20%,25V,Y5V,TP,1608,	

Loc. No	Part No	Description and Specification	Remark
RC36	2203-001556	C-CERAMIC,CHIP;100NF,+80-20%,25V,Y5V,TP,1608,	
RC37	2203-001556	C-CERAMIC,CHIP;100NF,+80-20%,25V,Y5V,TP,1608,	
RC38	2203-001556	C-CERAMIC,CHIP;100NF,+80-20%,25V,Y5V,TP,1608,	
RC39	2203-000440	C-CERAMIC,CHIP;1NF,10%,50V,X7R,TP,1608,-	
RC4	2203-001609	C-CERAMIC,CHIP;22NF,10%,16V,X7R,TP,1608,1.6MM	
RC40	2203-000440	C-CERAMIC,CHIP;1NF,10%,50V,X7R,TP,1608,-	
RC41	2203-001556	C-CERAMIC,CHIP;100NF,+80-20%,25V,Y5V,TP,1608,	
RC50	2203-001556	C-CERAMIC,CHIP;100NF,+80-20%,25V,Y5V,TP,1608,	
RC50A	2203-001556	C-CERAMIC,CHIP;100NF,+80-20%,25V,Y5V,TP,1608,	
RC51	2203-001556	C-CERAMIC,CHIP;100NF,+80-20%,25V,Y5V,TP,1608,	
RC6	2203-001609	C-CERAMIC,CHIP;22NF,10%,16V,X7R,TP,1608,1.6MM	
RC7	2401-001912	C-AL;1UF,20%,50V,GP,BK,5X11MM,2MM	
RC8	2401-001975	C-AL;47UF,20%,16V,GP,TP,5X11MM,5	
RC8A	2203-001556	C-CERAMIC,CHIP;100NF,+80-20%,25V,Y5V,TP,1608,	
RC9	2203-001556	C-CERAMIC,CHIP;100NF,+80-20%,25V,Y5V,TP,1608,	
RC9A	2203-001556	C-CERAMIC,CHIP;100NF,+80-20%,25V,Y5V,TP,1608,	
RCA1	3722-001136	JACK-RCA;6P,3.2MM,AU,R,G,B,-	
RCA3	3722-001145	JACK-RCA;6P/2C,3.2MM,AU,G/W/R,NO	
RCA5	3722-001134	JACK-RCA;1P,3.2MM,AU,BLK,-	
RCA8S	3722-001137	JACK-RCA;2P,3.2MM,AU,BLACK,-	
RIC1	AH13-10030H	IC-ASIC;-,TA1236F,QFP,64P,RF IC	
RIC2	AH13-10030J	IC-ASIC;-,TA1253FN,SSOP,24P,DPD IC	
RIC3	1201-001054	IC-OP AMP;650,SOP,8P,-,SINGLE,-,PLASTIC,	
RL1	2703-000122	INDUCTOR-SMD;10UH,10%,2.5X3.2X2MM	
RL10	2007-000029	R-CHIP;0OHM,5%,1/10W,DA,TP,2012	
RL10A	3301-000319	CORE-FERRITE BEAD;AB,2.0X1.25X0.9MM,1000,3000G	
RL2	2007-000029	R-CHIP;0OHM,5%,1/10W,DA,TP,2012	
RL3	2007-000029	R-CHIP;0OHM,5%,1/10W,DA,TP,2012	
RL4	2007-000029	R-CHIP;0OHM,5%,1/10W,DA,TP,2012	
RL7	2007-000029	R-CHIP;0OHM,5%,1/10W,DA,TP,2012	
RL8	2007-000029	R-CHIP;0OHM,5%,1/10W,DA,TP,2012	
RL9	2007-000029	R-CHIP;0OHM,5%,1/10W,DA,TP,2012	
RQ1	0501-002034	TR-SMALL SIGNAL;SS9012,PNP,-40V,-20V,-500MA,62	
RR10	2007-000086	R-CHIP;5.6KOHM,5%,1/16W,DA,TP,1608	
RR11	2007-001026	R-CHIP;560KOHM,5%,1/16W,DA,TP,1608	
RR12A	2007-000090	R-CHIP;10KOHM,5%,1/16W,DA,TP,1608	
RR13A	2007-000124	R-CHIP;2.2KOHM,5%,1/16W,DA,TP,1608	
RR14	2007-000122	R-CHIP;1.2KOHM,5%,1/16W,DA,TP,1608	
RR18	2007-000081	R-CHIP;2.7KOHM,5%,1/16W,DA,TP,1608	
RR18A	2007-000081	R-CHIP;2.7KOHM,5%,1/16W,DA,TP,1608	
RR18B	2007-000078	R-CHIP;1KOHM,5%,1/16W,DA,TP,1608	
RR19	2007-000078	R-CHIP;1KOHM,5%,1/16W,DA,TP,1608	
RR20	2007-000078	R-CHIP;1KOHM,5%,1/16W,DA,TP,1608	
RR21	2007-000075	R-CHIP;220OHM,5%,1/16W,DA,TP,1608	
RR22	2007-000078	R-CHIP;1KOHM,5%,1/16W,DA,TP,1608	
RR23	2007-000090	R-CHIP;10KOHM,5%,1/16W,DA,TP,1608	
RR24	2007-000078	R-CHIP;1KOHM,5%,1/16W,DA,TP,1608	
RR25	2007-000082	R-CHIP;3.3KOHM,5%,1/16W,DA,TP,1608	
RR26	2007-000100	R-CHIP;68KOHM,5%,1/16W,DA,TP,1608	
RR26A	2007-000090	R-CHIP;10KOHM,5%,1/16W,DA,TP,1608	
RR28	2007-000090	R-CHIP;10KOHM,5%,1/16W,DA,TP,1608	
RR28A	2007-000082	R-CHIP;3.3KOHM,5%,1/16W,DA,TP,1608	
RR29	2007-000070	R-CHIP;0OHM,5%,1/16W,DA,TP,1608	
RR3	2007-000090	R-CHIP;10KOHM,5%,1/16W,DA,TP,1608	
RR30	2007-000070	R-CHIP;0OHM,5%,1/16W,DA,TP,1608	

Loc. No	Part No	Description and Specification	Remark
RR31	2007-000070	R-CHIP:0OHM,5%,1/16W,DA,TP,1608	
RR31A	2007-000078	R-CHIP:1KOHM,5%,1/16W,DA,TP,1608	
RR33	2007-000090	R-CHIP:10KOHM,5%,1/16W,DA,TP,1608	
RR34	2007-000093	R-CHIP:20KOHM,5%,1/16W,DA,TP,1608	
RR35	2007-000130	R-CHIP:39KOHM,5%,1/16W,DA,TP,1608	
RR36	2007-001010	R-CHIP:51KOHM,5%,1/16W,DA,TP,1608	
RR36A	2007-000090	R-CHIP:10KOHM,5%,1/16W,DA,TP,1608	
RR37	2007-000100	R-CHIP:68KOHM,5%,1/16W,DA,TP,1608	
RR38	2007-000097	R-CHIP:47KOHM,5%,1/16W,DA,TP,1608	
RR38A	2007-000102	R-CHIP:100KOHM,5%,1/16W,DA,TP,1608	
RR38B	2007-000129	R-CHIP:27KOHM,5%,1/16W,DA,TP,1608	
RR38C	2007-001010	R-CHIP:51KOHM,5%,1/16W,DA,TP,1608	
RR40	2007-001179	R-CHIP:8.2KOHM,5%,1/16W,DA,TP,1608	
RR40A	2007-000078	R-CHIP:1KOHM,5%,1/16W,DA,TP,1608	
RR41A	2007-000101	R-CHIP:82KOHM,5%,1/16W,DA,TP,1608	
RR43	2007-000092	R-CHIP:15KOHM,5%,1/16W,DA,TP,1608	
RR45	2007-000086	R-CHIP:5.6KOHM,5%,1/16W,DA,TP,1608	
RR46	2007-000070	R-CHIP:0OHM,5%,1/16W,DA,TP,1608	
RR5	2007-000119	R-CHIP:560OHM,5%,1/16W,DA,TP,1608	
RR50	2007-000086	R-CHIP:5.6KOHM,5%,1/16W,DA,TP,1608	
RR51	2007-000086	R-CHIP:5.6KOHM,5%,1/16W,DA,TP,1608	
RR53	2007-000070	R-CHIP:0OHM,5%,1/16W,DA,TP,1608	
RR6	2007-000090	R-CHIP:10KOHM,5%,1/16W,DA,TP,1608	
RR7	2007-000361	R-CHIP:12OHM,5%,1/10W,DA,TP,2012	
SC1	2203-001703	C-CERAMIC,CHIP:560PF,10%,50V,X7R,TP,1608,-	
SC10	2203-000257	C-CERAMIC,CHIP:10NF,10%,50V,X7R,TP,1608,-	
SC11	2203-001656	C-CERAMIC,CHIP:470PF,5%,50V,CH,TP,1608,1.6MM	
SC15	2203-001556	C-CERAMIC,CHIP:100NF,+80-20%,25V,Y5V,TP,1608,	
SC19	2203-000257	C-CERAMIC,CHIP:10NF,10%,50V,X7R,TP,1608,-	
SC2	2401-001975	C-AL:47UF,20%,16V,GP,TP,5X11MM,5	
SC20	2203-000440	C-CERAMIC,CHIP:1NF,10%,50V,X7R,TP,1608,-	
SC21	2203-001556	C-CERAMIC,CHIP:100NF,+80-20%,25V,Y5V,TP,1608,	
SC22	2203-001556	C-CERAMIC,CHIP:100NF,+80-20%,25V,Y5V,TP,1608,	
SC23	2203-001556	C-CERAMIC,CHIP:100NF,+80-20%,25V,Y5V,TP,1608,	
SC24	2203-001556	C-CERAMIC,CHIP:100NF,+80-20%,25V,Y5V,TP,1608,	
SC25	2203-001556	C-CERAMIC,CHIP:100NF,+80-20%,25V,Y5V,TP,1608,	
SC25A	2203-001556	C-CERAMIC,CHIP:100NF,+80-20%,25V,Y5V,TP,1608,	
SC26A	2203-000888	C-CERAMIC,CHIP:4.7NF,10%,50V,X7R,TP,1608,-	
SC27	2401-001975	C-AL:47UF,20%,16V,GP,TP,5X11MM,5	
SC28	2203-001556	C-CERAMIC,CHIP:100NF,+80-20%,25V,Y5V,TP,1608,	
SC28A	2203-001556	C-CERAMIC,CHIP:100NF,+80-20%,25V,Y5V,TP,1608,	
SC29	2203-001556	C-CERAMIC,CHIP:100NF,+80-20%,25V,Y5V,TP,1608,	
SC3	2203-001556	C-CERAMIC,CHIP:100NF,+80-20%,25V,Y5V,TP,1608,	
SC31	2203-001556	C-CERAMIC,CHIP:100NF,+80-20%,25V,Y5V,TP,1608,	
SC32	2203-001556	C-CERAMIC,CHIP:100NF,+80-20%,25V,Y5V,TP,1608,	
SC33	2203-001556	C-CERAMIC,CHIP:100NF,+80-20%,25V,Y5V,TP,1608,	
SC34	2203-001556	C-CERAMIC,CHIP:100NF,+80-20%,25V,Y5V,TP,1608,	
SC35	2203-001556	C-CERAMIC,CHIP:100NF,+80-20%,25V,Y5V,TP,1608,	
SC36	2401-001975	C-AL:47UF,20%,16V,GP,TP,5X11MM,5	
SC37	2401-001975	C-AL:47UF,20%,16V,GP,TP,5X11MM,5	
SC39	2203-000257	C-CERAMIC,CHIP:10NF,10%,50V,X7R,TP,1608,-	
SC4	2203-000257	C-CERAMIC,CHIP:10NF,10%,50V,X7R,TP,1608,-	
SC40	2203-000257	C-CERAMIC,CHIP:10NF,10%,50V,X7R,TP,1608,-	
SC41	2203-000257	C-CERAMIC,CHIP:10NF,10%,50V,X7R,TP,1608,-	
SC42	2203-001556	C-CERAMIC,CHIP:100NF,+80-20%,25V,Y5V,TP,1608,	

Loc. No	Part No	Description and Specification	Remark
SC43	2203-001588	C-CERAMIC,CHIP;18PF,5%,50V,CH,TP,1608,1.6MM	
SC43A	2203-001609	C-CERAMIC,CHIP;22NF,10%,16V,X7R,TP,1608,1.6MM	
SC44	2203-001588	C-CERAMIC,CHIP;18PF,5%,50V,CH,TP,1608,1.6MM	
SC45	2203-000257	C-CERAMIC,CHIP;10NF,10%,50V,X7R,TP,1608,-	
SC46	2203-001556	C-CERAMIC,CHIP;100NF,+80-20%,25V,Y5V,TP,1608,	
SC47	2203-000054	C-CERAMIC,CHIP;15NF,0.1,50V,X7R,1608,-,TP	
SC48	2401-001975	C-AL;47UF,20%,16V,GP,TP,5X11MM,5	
SC49	2203-000257	C-CERAMIC,CHIP;10NF,10%,50V,X7R,TP,1608,-	
SC5	2203-000257	C-CERAMIC,CHIP;10NF,10%,50V,X7R,TP,1608,-	
SC50	2203-000726	C-CERAMIC,CHIP;3.9NF,10%,50V,X7R,TP,1608,-	
SC50A	2203-001559	C-CERAMIC,CHIP;100PF,5%,50V,NPO,TP,1608,1.6MM	
SC51	2203-000726	C-CERAMIC,CHIP;3.9NF,10%,50V,X7R,TP,1608,-	
SC52	2401-001975	C-AL;47UF,20%,16V,GP,TP,5X11MM,5	
SC53	2203-000257	C-CERAMIC,CHIP;10NF,10%,50V,X7R,TP,1608,-	
SC54	2203-001556	C-CERAMIC,CHIP;100NF,+80-20%,25V,Y5V,TP,1608,	
SC55	2203-000257	C-CERAMIC,CHIP;10NF,10%,50V,X7R,TP,1608,-	
SC55A	2203-000257	C-CERAMIC,CHIP;10NF,10%,50V,X7R,TP,1608,-	
SC56	2203-000257	C-CERAMIC,CHIP;10NF,10%,50V,X7R,TP,1608,-	
SC57	2203-000257	C-CERAMIC,CHIP;10NF,10%,50V,X7R,TP,1608,-	
SC58	2203-000257	C-CERAMIC,CHIP;10NF,10%,50V,X7R,TP,1608,-	
SC59	2401-001975	C-AL;47UF,20%,16V,GP,TP,5X11MM,5	
SC5A	2203-000257	C-CERAMIC,CHIP;10NF,10%,50V,X7R,TP,1608,-	
SC5B	2203-000257	C-CERAMIC,CHIP;10NF,10%,50V,X7R,TP,1608,-	
SC5C	2203-001556	C-CERAMIC,CHIP;100NF,+80-20%,25V,Y5V,TP,1608,	
SC6	2203-001703	C-CERAMIC,CHIP;560PF,10%,50V,X7R,TP,1608,-	
SC60	2203-000257	C-CERAMIC,CHIP;10NF,10%,50V,X7R,TP,1608,-	
SC62	2203-000257	C-CERAMIC,CHIP;10NF,10%,50V,X7R,TP,1608,-	
SC63	2203-001556	C-CERAMIC,CHIP;100NF,+80-20%,25V,Y5V,TP,1608,	
SC65	2203-000257	C-CERAMIC,CHIP;10NF,10%,50V,X7R,TP,1608,-	
SC67	2203-001556	C-CERAMIC,CHIP;100NF,+80-20%,25V,Y5V,TP,1608,	
SC69	2401-001975	C-AL;47UF,20%,16V,GP,TP,5X11MM,5	
SC7	2203-001556	C-CERAMIC,CHIP;100NF,+80-20%,25V,Y5V,TP,1608,	
SC70	2203-001556	C-CERAMIC,CHIP;100NF,+80-20%,25V,Y5V,TP,1608,	
SC71	2203-001559	C-CERAMIC,CHIP;100PF,5%,50V,NPO,TP,1608,1.6MM	
SC72	2401-001975	C-AL;47UF,20%,16V,GP,TP,5X11MM,5	
SC73	2203-001556	C-CERAMIC,CHIP;100NF,+80-20%,25V,Y5V,TP,1608,	
SC8	2203-001634	C-CERAMIC,CHIP;33NF,10%,50V,X7R,TP,1608,1.6MM	
SC9	2203-001556	C-CERAMIC,CHIP;100NF,+80-20%,25V,Y5V,TP,1608,	
SIC1	1201-000163	IC-OP AMP;4560,SOP,8P,150MIL,DUAL,100V/M	
SIC2	BG13-10030A	IC-ASIC;SCR-730,SEC,SOP,24P,HALL CONTRBG13	
SIC4	1003-001083	IC-MOTOR DRIVER;BA5924FP,SOP,28P,767MIL,SINGLE	
SIC5	1003-001044	IC-MOTOR DRIVER;BA6840BFP,SOP,28P,292MIL,SINGL	
SIC6	1201-000163	IC-OP AMP;4560,SOP,8P,150MIL,DUAL,100V/M	
SIC6A	1202-000143	IC-VOLTAGE COMP;75S393,SOP,5P,-,SINGLE,0V,-,PL	
SIC7	AH13-10030G	IC-ASIC;-,TC9420F,QFP,100P,DIGITAL SER	
SIC8	1201-000163	IC-OP AMP;4560,SOP,8P,150MIL,DUAL,100V/M	
SIC9	0803-001040	IC-TTL;74LS14,SCHIMITT INVERTER,SOP,1	
SQ1	0505-000191	FET-SILICON;2SK184Y,N,-,-,200MW,TO-92	
SQ11	0504-000128	TR-DIGITAL;- ,NPN,200MW,22K-22KOHM,SOT-23,	
SQ12	0504-000128	TR-DIGITAL;- ,NPN,200MW,22K-22KOHM,SOT-23,	
SQ13	0504-000128	TR-DIGITAL;- ,NPN,200MW,22K-22KOHM,SOT-23,	
SQ14	0504-000128	TR-DIGITAL;- ,NPN,200MW,22K-22KOHM,SOT-23,	
SQ2	0504-000128	TR-DIGITAL;- ,NPN,200MW,22K-22KOHM,SOT-23,	
SQ2A	0504-000128	TR-DIGITAL;- ,NPN,200MW,22K-22KOHM,SOT-23,	
SQ3	0504-000156	TR-DIGITAL;KSR2103,PNP,200MW,22K-22K,SOT-	

Loc. No	Part No	Description and Specification	Remark
SR1	2007-000077	R-CHIP:470OHM,5%,1/16W,DA,TP,1608	
SR10	2007-000084	R-CHIP:4.7KOHM,5%,1/16W,DA,TP,1608	
SR11	2007-000091	R-CHIP:12KOHM,5%,1/16W,DA,TP,1608	
SR12	2007-000087	R-CHIP:6.8KOHM,5%,1/16W,DA,TP,1608	
SR13	2007-000079	R-CHIP:1.8KOHM,5%,1/16W,DA,TP,1608	
SR13A	2007-000079	R-CHIP:1.8KOHM,5%,1/16W,DA,TP,1608	
SR13B	2007-000078	R-CHIP:1KOHM,5%,1/16W,DA,TP,1608	
SR14	2007-000097	R-CHIP:47KOHM,5%,1/16W,DA,TP,1608	
SR15	2007-000079	R-CHIP:1.8KOHM,5%,1/16W,DA,TP,1608	
SR16	2007-000091	R-CHIP:12KOHM,5%,1/16W,DA,TP,1608	
SR17	2007-000078	R-CHIP:1KOHM,5%,1/16W,DA,TP,1608	
SR18	2007-000091	R-CHIP:12KOHM,5%,1/16W,DA,TP,1608	
SR19	2007-000091	R-CHIP:12KOHM,5%,1/16W,DA,TP,1608	
SR2	2007-000077	R-CHIP:470OHM,5%,1/16W,DA,TP,1608	
SR20	2007-000106	R-CHIP:220KOHM,5%,1/16W,DA,TP,1608	
SR21	2007-000084	R-CHIP:4.7KOHM,5%,1/16W,DA,TP,1608	
SR22	2007-000107	R-CHIP:470KOHM,5%,1/16W,DA,TP,1608	
SR23	2007-000084	R-CHIP:4.7KOHM,5%,1/16W,DA,TP,1608	
SR24	2007-000092	R-CHIP:15KOHM,5%,1/16W,DA,TP,1608	
SR24A	2007-000123	R-CHIP:1.5KOHM,5%,1/16W,DA,TP,1608	
SR25	2007-000092	R-CHIP:15KOHM,5%,1/16W,DA,TP,1608	
SR25A	2007-000123	R-CHIP:1.5KOHM,5%,1/16W,DA,TP,1608	
SR26	2007-000124	R-CHIP:2.2KOHM,5%,1/16W,DA,TP,1608	
SR27	2007-000091	R-CHIP:12KOHM,5%,1/16W,DA,TP,1608	
SR27A	2007-000133	R-CHIP:330KOHM,5%,1/16W,DA,TP,1608	
SR28A	2007-000070	R-CHIP:0OHM,5%,1/16W,DA,TP,1608	
SR28B	2007-000070	R-CHIP:0OHM,5%,1/16W,DA,TP,1608	
SR28C	2007-001179	R-CHIP:8.2KOHM,5%,1/16W,DA,TP,1608	
SR29	2007-000070	R-CHIP:0OHM,5%,1/16W,DA,TP,1608	
SR29A	2007-000070	R-CHIP:0OHM,5%,1/16W,DA,TP,1608	
SR3	2007-000077	R-CHIP:470OHM,5%,1/16W,DA,TP,1608	
SR30	2007-000070	R-CHIP:0OHM,5%,1/16W,DA,TP,1608	
SR30A	2007-000086	R-CHIP:5.6KOHM,5%,1/16W,DA,TP,1608	
SR30B	2007-000127	R-CHIP:9.1KOHM,5%,1/16W,DA,TP,1608	
SR31	2007-000101	R-CHIP:82KOHM,5%,1/16W,DA,TP,1608	
SR32	2007-000101	R-CHIP:82KOHM,5%,1/16W,DA,TP,1608	
SR33	2007-000087	R-CHIP:6.8KOHM,5%,1/16W,DA,TP,1608	
SR34	2007-000450	R-CHIP:180OHM,5%,1/16W,DA,TP,1608	
SR34A	2007-000078	R-CHIP:1KOHM,5%,1/16W,DA,TP,1608	
SR34B	2007-000074	R-CHIP:100OHM,5%,1/16W,DA,TP,1608	
SR35	2007-000086	R-CHIP:5.6KOHM,5%,1/16W,DA,TP,1608	
SR36	2007-000450	R-CHIP:180OHM,5%,1/16W,DA,TP,1608	
SR36A	2007-000090	R-CHIP:10KOHM,5%,1/16W,DA,TP,1608	
SR36B	2007-000070	R-CHIP:0OHM,5%,1/16W,DA,TP,1608	
SR37	2007-007157	R-CHIP:1OHM,5%,1/4W,DA,TP,3216	
SR37A	2007-007157	R-CHIP:1OHM,5%,1/4W,DA,TP,3216	
SR38	2007-000458	R-CHIP:18KOHM,5%,1/16W,DA,TP,1608	
SR39	2007-000124	R-CHIP:2.2KOHM,5%,1/16W,DA,TP,1608	
SR4	2007-000077	R-CHIP:470OHM,5%,1/16W,DA,TP,1608	
SR40	2007-000100	R-CHIP:68KOHM,5%,1/16W,DA,TP,1608	
SR41	2007-000091	R-CHIP:12KOHM,5%,1/16W,DA,TP,1608	
SR42	2007-000086	R-CHIP:5.6KOHM,5%,1/16W,DA,TP,1608	
SR43	2007-000458	R-CHIP:18KOHM,5%,1/16W,DA,TP,1608	
SR44	2007-000099	R-CHIP:62KOHM,5%,1/16W,DA,TP,1608	
SR44A	2007-000078	R-CHIP:1KOHM,5%,1/16W,DA,TP,1608	

Loc. No	Part No	Description and Specification	Remark
SR45	2007-000078	R-CHIP;1KOHM,5%,1/16W,DA,TP,1608	
SR49	2007-000124	R-CHIP;2.2KOHM,5%,1/16W,DA,TP,1608	
SR5	2007-000129	R-CHIP;27KOHM,5%,1/16W,DA,TP,1608	
SR50	2007-000078	R-CHIP;1KOHM,5%,1/16W,DA,TP,1608	
SR51	2007-000092	R-CHIP;15KOHM,5%,1/16W,DA,TP,1608	
SR52	2007-000090	R-CHIP;10KOHM,5%,1/16W,DA,TP,1608	
SR53	2007-000078	R-CHIP;1KOHM,5%,1/16W,DA,TP,1608	
SR54	2007-000078	R-CHIP;1KOHM,5%,1/16W,DA,TP,1608	
SR55	2007-000090	R-CHIP;10KOHM,5%,1/16W,DA,TP,1608	
SR56	2007-000074	R-CHIP;100OHM,5%,1/16W,DA,TP,1608	
SR56A	2007-000070	R-CHIP;0OHM,5%,1/16W,DA,TP,1608	
SR57	2007-000078	R-CHIP;1KOHM,5%,1/16W,DA,TP,1608	
SR58	2007-000090	R-CHIP;10KOHM,5%,1/16W,DA,TP,1608	
SR59	2007-000124	R-CHIP;2.2KOHM,5%,1/16W,DA,TP,1608	
SR6	2007-000081	R-CHIP;2.7KOHM,5%,1/16W,DA,TP,1608	
SR60	2007-000124	R-CHIP;2.2KOHM,5%,1/16W,DA,TP,1608	
SR61A	2007-000078	R-CHIP;1KOHM,5%,1/16W,DA,TP,1608	
SR61B	2007-000070	R-CHIP;0OHM,5%,1/16W,DA,TP,1608	
SR63	2007-000070	R-CHIP;0OHM,5%,1/16W,DA,TP,1608	
SR63A	2007-000070	R-CHIP;0OHM,5%,1/16W,DA,TP,1608	
SR68	2007-000070	R-CHIP;0OHM,5%,1/16W,DA,TP,1608	
SR7	2007-000081	R-CHIP;2.7KOHM,5%,1/16W,DA,TP,1608	
SR70	2007-000134	R-CHIP;33KOHM,5%,1/16W,DA,TP,1608	
SR71	2007-000092	R-CHIP;15KOHM,5%,1/16W,DA,TP,1608	
SR73	2007-000074	R-CHIP;100OHM,5%,1/16W,DA,TP,1608	
SR74	2007-000065	R-CHIP;2.2MOHM,5%,1/16W,DA,TP,1608	
SR77	2007-000133	R-CHIP;330KOHM,5%,1/16W,DA,TP,1608	
SR78	2007-000090	R-CHIP;10KOHM,5%,1/16W,DA,TP,1608	
SR79	2007-000097	R-CHIP;47KOHM,5%,1/16W,DA,TP,1608	
SR8	2007-000081	R-CHIP;2.7KOHM,5%,1/16W,DA,TP,1608	
SR80	2007-000074	R-CHIP;100OHM,5%,1/16W,DA,TP,1608	
SR81	2007-000074	R-CHIP;100OHM,5%,1/16W,DA,TP,1608	
SR82	2007-000074	R-CHIP;100OHM,5%,1/16W,DA,TP,1608	
SR83	2007-000074	R-CHIP;100OHM,5%,1/16W,DA,TP,1608	
SR84	2007-000074	R-CHIP;100OHM,5%,1/16W,DA,TP,1608	
SR85	2007-000078	R-CHIP;1KOHM,5%,1/16W,DA,TP,1608	
SR89	2007-000074	R-CHIP;100OHM,5%,1/16W,DA,TP,1608	
SR9	2007-000129	R-CHIP;27KOHM,5%,1/16W,DA,TP,1608	
SR90	2007-000074	R-CHIP;100OHM,5%,1/16W,DA,TP,1608	
SR91	2007-000074	R-CHIP;100OHM,5%,1/16W,DA,TP,1608	
SR92	2007-000074	R-CHIP;100OHM,5%,1/16W,DA,TP,1608	
SR93	2007-000074	R-CHIP;100OHM,5%,1/16W,DA,TP,1608	
SR94	2007-000084	R-CHIP;4.7KOHM,5%,1/16W,DA,TP,1608	
SR95	2007-000084	R-CHIP;4.7KOHM,5%,1/16W,DA,TP,1608	
SR96	2007-000078	R-CHIP;1KOHM,5%,1/16W,DA,TP,1608	
SR97	2007-000078	R-CHIP;1KOHM,5%,1/16W,DA,TP,1608	
SUPER	3722-001133	JACK-DIN;4P,-,NI,BLK,-	
SX1	2801-003256	CRYSTAL-UNIT;16.9344MHZ,20PPM,28-AAA,18PF,4	
VC1	2203-001556	C-CERAMIC,CHIP;100NF,+80-20%,25V,Y5V,TP,1608,	
VC10	2203-001556	C-CERAMIC,CHIP;100NF,+80-20%,25V,Y5V,TP,1608,	
VC100	2203-001556	C-CERAMIC,CHIP;100NF,+80-20%,25V,Y5V,TP,1608,	
VC103	2401-000778	C-AL;220UF,20%,10V,GP,-,6.3X11,2.5M	
VC104	2401-001975	C-AL;47UF,20%,16V,GP,TP,5X11MM,5	
VC105	2203-001556	C-CERAMIC,CHIP;100NF,+80-20%,25V,Y5V,TP,1608,	
VC107	2203-001609	C-CERAMIC,CHIP;22NF,10%,16V,X7R,TP,1608,1.6MM	



Loc. No	Part No	Description and Specification	Remark
VC108	2203-001556	C-CERAMIC,CHIP;100NF,+80-20%,25V,Y5V,TP,1608,	
VC109	2203-000440	C-CERAMIC,CHIP;1NF,10%,50V,X7R,TP,1608,-	
VC11	2203-001556	C-CERAMIC,CHIP;100NF,+80-20%,25V,Y5V,TP,1608,	
VC110	2401-001912	C-AL;1UF,20%,50V,GP,BK,5X11MM,2MM	
VC111	2203-000531	C-CERAMIC,CHIP;2.7NF,10%,50V,X7R,TP,1608,-	
VC112	2401-001912	C-AL;1UF,20%,50V,GP,BK,5X11MM,2MM	
VC113	2203-001559	C-CERAMIC,CHIP;100PF,5%,50V,NPO,TP,1608,1.6MM	
VC114	2203-005083	C-CERAMIC,CHIP;220NF,10%,50V,X7R,TP,1608,-	
VC115	2203-001556	C-CERAMIC,CHIP;100NF,+80-20%,25V,Y5V,TP,1608,	
VC12	2203-001556	C-CERAMIC,CHIP;100NF,+80-20%,25V,Y5V,TP,1608,	
VC122	2401-001975	C-AL;47UF,20%,16V,GP,TP,5X11MM,5	
VC123	2203-001556	C-CERAMIC,CHIP;100NF,+80-20%,25V,Y5V,TP,1608,	
VC124	2203-001556	C-CERAMIC,CHIP;100NF,+80-20%,25V,Y5V,TP,1608,	
VC125	2203-001556	C-CERAMIC,CHIP;100NF,+80-20%,25V,Y5V,TP,1608,	
VC126	2203-001556	C-CERAMIC,CHIP;100NF,+80-20%,25V,Y5V,TP,1608,	
VC127	2203-001556	C-CERAMIC,CHIP;100NF,+80-20%,25V,Y5V,TP,1608,	
VC128	2203-000257	C-CERAMIC,CHIP;10NF,10%,50V,X7R,TP,1608,-	
VC129	2203-001556	C-CERAMIC,CHIP;100NF,+80-20%,25V,Y5V,TP,1608,	
VC13	2203-001556	C-CERAMIC,CHIP;100NF,+80-20%,25V,Y5V,TP,1608,	
VC131	2203-001556	C-CERAMIC,CHIP;100NF,+80-20%,25V,Y5V,TP,1608,	
VC132	2401-001895	C-AL;100UF,20%,16V,GP,BK,6.3X11MM,2	
VC133	2401-001895	C-AL;100UF,20%,16V,GP,BK,6.3X11MM,2	
VC135	2203-001556	C-CERAMIC,CHIP;100NF,+80-20%,25V,Y5V,TP,1608,	
VC136	2203-000384	C-CERAMIC,CHIP;15PF,5%,50V,NPO,TP,1608,-	
VC137	2203-000384	C-CERAMIC,CHIP;15PF,5%,50V,NPO,TP,1608,-	
VC138	2203-001556	C-CERAMIC,CHIP;100NF,+80-20%,25V,Y5V,TP,1608,	
VC139	2203-001556	C-CERAMIC,CHIP;100NF,+80-20%,25V,Y5V,TP,1608,	
VC14	2203-001556	C-CERAMIC,CHIP;100NF,+80-20%,25V,Y5V,TP,1608,	
VC15	2203-001556	C-CERAMIC,CHIP;100NF,+80-20%,25V,Y5V,TP,1608,	
VC16	2203-001556	C-CERAMIC,CHIP;100NF,+80-20%,25V,Y5V,TP,1608,	
VC17	2203-005083	C-CERAMIC,CHIP;220NF,10%,50V,X7R,TP,1608,-	
VC18	2203-005083	C-CERAMIC,CHIP;220NF,10%,50V,X7R,TP,1608,-	
VC19	2203-005083	C-CERAMIC,CHIP;220NF,10%,50V,X7R,TP,1608,-	
VC2	2203-001556	C-CERAMIC,CHIP;100NF,+80-20%,25V,Y5V,TP,1608,	
VC20	2203-005083	C-CERAMIC,CHIP;220NF,10%,50V,X7R,TP,1608,-	
VC21	2203-005083	C-CERAMIC,CHIP;220NF,10%,50V,X7R,TP,1608,-	
VC22	2203-005083	C-CERAMIC,CHIP;220NF,10%,50V,X7R,TP,1608,-	
VC23	2203-005083	C-CERAMIC,CHIP;220NF,10%,50V,X7R,TP,1608,-	
VC24	2203-005083	C-CERAMIC,CHIP;220NF,10%,50V,X7R,TP,1608,-	
VC25	2203-005083	C-CERAMIC,CHIP;220NF,10%,50V,X7R,TP,1608,-	
VC26	2203-001556	C-CERAMIC,CHIP;100NF,+80-20%,25V,Y5V,TP,1608,	
VC28	2203-005083	C-CERAMIC,CHIP;220NF,10%,50V,X7R,TP,1608,-	
VC29	2203-005083	C-CERAMIC,CHIP;220NF,10%,50V,X7R,TP,1608,-	
VC3	2203-001556	C-CERAMIC,CHIP;100NF,+80-20%,25V,Y5V,TP,1608,	
VC30	2203-005083	C-CERAMIC,CHIP;220NF,10%,50V,X7R,TP,1608,-	
VC31	2203-001556	C-CERAMIC,CHIP;100NF,+80-20%,25V,Y5V,TP,1608,	
VC32	2203-001556	C-CERAMIC,CHIP;100NF,+80-20%,25V,Y5V,TP,1608,	
VC34	2203-001556	C-CERAMIC,CHIP;100NF,+80-20%,25V,Y5V,TP,1608,	
VC35	2401-001975	C-AL;47UF,20%,16V,GP,TP,5X11MM,5	
VC36	2203-005083	C-CERAMIC,CHIP;220NF,10%,50V,X7R,TP,1608,-	
VC37	2203-005083	C-CERAMIC,CHIP;220NF,10%,50V,X7R,TP,1608,-	
VC38	2203-005083	C-CERAMIC,CHIP;220NF,10%,50V,X7R,TP,1608,-	
VC39	2401-001975	C-AL;47UF,20%,16V,GP,TP,5X11MM,5	
VC4	2203-001556	C-CERAMIC,CHIP;100NF,+80-20%,25V,Y5V,TP,1608,	
VC40	2203-001556	C-CERAMIC,CHIP;100NF,+80-20%,25V,Y5V,TP,1608,	

Loc. No	Part No	Description and Specification	Remark
VC41	2203-001556	C-CERAMIC,CHIP;100NF,+80-20%,25V,Y5V,TP,1608,	
VC43	2401-000907	C-AL;22UF,20%,16V,GP,-,5X11,2MM	
VC44	2401-000778	C-AL;220UF,20%,10V,GP,-,6.3X11,2.5M	
VC47	2203-001556	C-CERAMIC,CHIP;100NF,+80-20%,25V,Y5V,TP,1608,	
VC48	2401-001975	C-AL;47UF,20%,16V,GP,TP,5X11MM,5	
VC5	2203-001556	C-CERAMIC,CHIP;100NF,+80-20%,25V,Y5V,TP,1608,	
VC50	2203-001556	C-CERAMIC,CHIP;100NF,+80-20%,25V,Y5V,TP,1608,	
VC51	2203-005083	C-CERAMIC,CHIP;220NF,10%,50V,X7R,TP,1608,-	
VC52	2203-001556	C-CERAMIC,CHIP;100NF,+80-20%,25V,Y5V,TP,1608,	
VC53	2203-001556	C-CERAMIC,CHIP;100NF,+80-20%,25V,Y5V,TP,1608,	
VC54	2401-001975	C-AL;47UF,20%,16V,GP,TP,5X11MM,5	
VC55	2401-000778	C-AL;220UF,20%,10V,GP,-,6.3X11,2.5M	
VC56	2401-000778	C-AL;220UF,20%,10V,GP,-,6.3X11,2.5M	
VC57	2401-000778	C-AL;220UF,20%,10V,GP,-,6.3X11,2.5M	
VC58	2203-001556	C-CERAMIC,CHIP;100NF,+80-20%,25V,Y5V,TP,1608,	
VC59	2401-001975	C-AL;47UF,20%,16V,GP,TP,5X11MM,5	
VC6	2203-001556	C-CERAMIC,CHIP;100NF,+80-20%,25V,Y5V,TP,1608,	
VC7	2203-001556	C-CERAMIC,CHIP;100NF,+80-20%,25V,Y5V,TP,1608,	
VC71	2203-001556	C-CERAMIC,CHIP;100NF,+80-20%,25V,Y5V,TP,1608,	
VC72	2401-001975	C-AL;47UF,20%,16V,GP,TP,5X11MM,5	
VC73	2203-001556	C-CERAMIC,CHIP;100NF,+80-20%,25V,Y5V,TP,1608,	
VC74	2401-001975	C-AL;47UF,20%,16V,GP,TP,5X11MM,5	
VC76	2401-000778	C-AL;220UF,20%,10V,GP,-,6.3X11,2.5M	
VC79	2401-001975	C-AL;47UF,20%,16V,GP,TP,5X11MM,5	
VC8	2203-001556	C-CERAMIC,CHIP;100NF,+80-20%,25V,Y5V,TP,1608,	
VC80	2203-001556	C-CERAMIC,CHIP;100NF,+80-20%,25V,Y5V,TP,1608,	
VC83	2203-001556	C-CERAMIC,CHIP;100NF,+80-20%,25V,Y5V,TP,1608,	
VC84	2203-001556	C-CERAMIC,CHIP;100NF,+80-20%,25V,Y5V,TP,1608,	
VC85	2401-001975	C-AL;47UF,20%,16V,GP,TP,5X11MM,5	
VC88	2203-001609	C-CERAMIC,CHIP;22NF,10%,16V,X7R,TP,1608,1.6MM	
VC89	2203-001556	C-CERAMIC,CHIP;100NF,+80-20%,25V,Y5V,TP,1608,	
VC9	2203-001556	C-CERAMIC,CHIP;100NF,+80-20%,25V,Y5V,TP,1608,	
VC90	2401-001975	C-AL;47UF,20%,16V,GP,TP,5X11MM,5	
VC91	2203-001556	C-CERAMIC,CHIP;100NF,+80-20%,25V,Y5V,TP,1608,	
VC93	2203-001556	C-CERAMIC,CHIP;100NF,+80-20%,25V,Y5V,TP,1608,	
VC94	2203-001556	C-CERAMIC,CHIP;100NF,+80-20%,25V,Y5V,TP,1608,	
VC95	2401-001975	C-AL;47UF,20%,16V,GP,TP,5X11MM,5	
VC99	2401-001975	C-AL;47UF,20%,16V,GP,TP,5X11MM,5	
VCN11	3708-001086	CONNECTOR-FPC/FC/PIC;28P,1.25MM,STRAIGHT,SN	
VCN14	AH37-20001U	JACK;M1795 D3.5,-	
VFLT1	2901-001025	FILTER-EMI SMD;25V,200MA,-,-,3.2X1.6X1.8,TP	
VFLT10	2901-001025	FILTER-EMI SMD;25V,200MA,-,-,3.2X1.6X1.8,TP	
VFLT2	2909-001022	FILTER-LC;-0~+7.5MHZ,4.5DB,TP,1.5~4.5DB	
VFLT3	2901-001025	FILTER-EMI SMD;25V,200MA,-,-,3.2X1.6X1.8,TP	
VFLT4	2909-001038	FILTER-LC;0.1MHZ,-,1DB,TP,3+-2.5DB/+7.5M	
VFLT5	2901-001025	FILTER-EMI SMD;25V,200MA,-,-,3.2X1.6X1.8,TP	
VFLT6	2901-001025	FILTER-EMI SMD;25V,200MA,-,-,3.2X1.6X1.8,TP	
VFLT7	2901-001025	FILTER-EMI SMD;25V,200MA,-,-,3.2X1.6X1.8,TP	
VFLT8	2901-001025	FILTER-EMI SMD;25V,200MA,-,-,3.2X1.6X1.8,TP	
VFLT9	2901-001025	FILTER-EMI SMD;25V,200MA,-,-,3.2X1.6X1.8,TP	
VIC1	1204-001196	IC-DECODER;DVD-1,QFP,208P,-,PLASTIC,5V,1.	
VIC10	0801-002166	IC-CMOS LOGIC;7SHU04,INVERTER GATE,SOP,5P,6.	
VIC12	0801-002096	IC-CMOS LOGIC;7SH08,AND GATE,SOP,5P,110MIL,S	
VIC14	0801-002097	IC-CMOS LOGIC;7SET08,AND GATE,SOP,5P,110MIL,	
VIC2	1102-001042	IC-EPROM;27C4096,256KX16BIT,DIP,40P,600	

Loc. No	Part No	Description and Specification	Remark
VIC3	1105-001009	IC-DRAM;416C254,256KX16BIT,SOJ,40P,102	
VIC31	1204-001197	IC-ENCODER;STV0119,SOP,28P,291MIL,PLASTIC	
VIC32	AH14-10004T	IC-ANALOG M/PLEXER;MC14053BD,SOP,TAPE 16P ANALOG	
VIC33	AC14-12012B	IC;BA7046F-T1,SOP,-	
VIC37	0801-000885	IC-CMOS LOGIC;7S04,INVERTER,SOP,5P,150MIL,SI	
VIC4	1105-001009	IC-DRAM;416C254,256KX16BIT,SOJ,40P,102	
VIC5	1105-001009	IC-DRAM;416C254,256KX16BIT,SOJ,40P,102	
VIC6	1105-001009	IC-DRAM;416C254,256KX16BIT,SOJ,40P,102	
VIC7	1105-001009	IC-DRAM;416C254,256KX16BIT,SOJ,40P,102	
VIC8	0801-002206	IC-CMOS LOGIC;74HC157,MULTIPLEXER,SOP,16P,15	
VIC9	0801-002206	IC-CMOS LOGIC;74HC157,MULTIPLEXER,SOP,16P,15	
VJP2	2007-000070	R-CHIP;0OHM,5%,1/16W,DA,TP,1608	
VL1	2007-000029	R-CHIP;0OHM,5%,1/10W,DA,TP,2012	
VL11	3301-000319	CORE-FERRITE BEAD;AB,2.0X1.25X0.9MM,1000,3000G	
VL12	3301-000319	CORE-FERRITE BEAD;AB,2.0X1.25X0.9MM,1000,3000G	
VL14	3301-000319	CORE-FERRITE BEAD;AB,2.0X1.25X0.9MM,1000,3000G	
VL15	3301-000319	CORE-FERRITE BEAD;AB,2.0X1.25X0.9MM,1000,3000G	
VL16	3301-000319	CORE-FERRITE BEAD;AB,2.0X1.25X0.9MM,1000,3000G	
VL17	3301-000319	CORE-FERRITE BEAD;AB,2.0X1.25X0.9MM,1000,3000G	
VL19	3301-000319	CORE-FERRITE BEAD;AB,2.0X1.25X0.9MM,1000,3000G	
VL2	3301-000319	CORE-FERRITE BEAD;AB,2.0X1.25X0.9MM,1000,3000G	
VL20	3301-000319	CORE-FERRITE BEAD;AB,2.0X1.25X0.9MM,1000,3000G	
VL21	3301-000319	CORE-FERRITE BEAD;AB,2.0X1.25X0.9MM,1000,3000G	
VL23	3301-000319	CORE-FERRITE BEAD;AB,2.0X1.25X0.9MM,1000,3000G	
VL24	3301-000319	CORE-FERRITE BEAD;AB,2.0X1.25X0.9MM,1000,3000G	
VL25	3301-000319	CORE-FERRITE BEAD;AB,2.0X1.25X0.9MM,1000,3000G	
VL26	3301-000319	CORE-FERRITE BEAD;AB,2.0X1.25X0.9MM,1000,3000G	
VL27	3301-000319	CORE-FERRITE BEAD;AB,2.0X1.25X0.9MM,1000,3000G	
VL28	3301-000319	CORE-FERRITE BEAD;AB,2.0X1.25X0.9MM,1000,3000G	
VL29	3301-000319	CORE-FERRITE BEAD;AB,2.0X1.25X0.9MM,1000,3000G	
VL3	3301-000319	CORE-FERRITE BEAD;AB,2.0X1.25X0.9MM,1000,3000G	
VL30	3301-000319	CORE-FERRITE BEAD;AB,2.0X1.25X0.9MM,1000,3000G	
VL4	3301-000319	CORE-FERRITE BEAD;AB,2.0X1.25X0.9MM,1000,3000G	
VL6	3301-000319	CORE-FERRITE BEAD;AB,2.0X1.25X0.9MM,1000,3000G	
VL7	3301-000319	CORE-FERRITE BEAD;AB,2.0X1.25X0.9MM,1000,3000G	
VL8	3301-000319	CORE-FERRITE BEAD;AB,2.0X1.25X0.9MM,1000,3000G	
VL9	3301-000319	CORE-FERRITE BEAD;AB,2.0X1.25X0.9MM,1000,3000G	
VQ1	0501-000341	TR-SMALL SIGNAL;KSC1623-L,NPN,200MW,SOT-23,TP,	
VQ10	0501-000341	TR-SMALL SIGNAL;KSC1623-L,NPN,200MW,SOT-23,TP,	
VQ11	0501-000341	TR-SMALL SIGNAL;KSC1623-L,NPN,200MW,SOT-23,TP,	
VQ12	0501-000314	TR-SMALL SIGNAL;KSA812,PNP,150MW,SOT-23,TP,90-	
VQ13	0501-000341	TR-SMALL SIGNAL;KSC1623-L,NPN,200MW,SOT-23,TP,	
VQ14	0501-000341	TR-SMALL SIGNAL;KSC1623-L,NPN,200MW,SOT-23,TP,	
VQ15	0501-000341	TR-SMALL SIGNAL;KSC1623-L,NPN,200MW,SOT-23,TP,	
VQ16	0501-000314	TR-SMALL SIGNAL;KSA812,PNP,150MW,SOT-23,TP,90-	
VQ17	0501-000341	TR-SMALL SIGNAL;KSC1623-L,NPN,200MW,SOT-23,TP,	
VQ18	0501-000341	TR-SMALL SIGNAL;KSC1623-L,NPN,200MW,SOT-23,TP,	
VQ19	0501-000341	TR-SMALL SIGNAL;KSC1623-L,NPN,200MW,SOT-23,TP,	
VQ2	0501-000341	TR-SMALL SIGNAL;KSC1623-L,NPN,200MW,SOT-23,TP,	
VQ20	0501-000314	TR-SMALL SIGNAL;KSA812,PNP,150MW,SOT-23,TP,90-	
VQ21	0501-000341	TR-SMALL SIGNAL;KSC1623-L,NPN,200MW,SOT-23,TP,	
VQ22	0501-000341	TR-SMALL SIGNAL;KSC1623-L,NPN,200MW,SOT-23,TP,	
VQ24	0501-000314	TR-SMALL SIGNAL;KSA812,PNP,150MW,SOT-23,TP,90-	
VQ26	0501-000341	TR-SMALL SIGNAL;KSC1623-L,NPN,200MW,SOT-23,TP,	
VQ27	0501-000341	TR-SMALL SIGNAL;KSC1623-L,NPN,200MW,SOT-23,TP,	

Loc. No	Part No	Description and Specification	Remark
VQ28	0501-000314	TR-SMALL SIGNAL;KSA812,PNP,150MW,SOT-23,TP,90-	
VQ29	0501-000341	TR-SMALL SIGNAL;KSC1623-L,NPN,200MW,SOT-23,TP,	
VQ3	0501-000314	TR-SMALL SIGNAL;KSA812,PNP,150MW,SOT-23,TP,90-	
VQ30	0501-000314	TR-SMALL SIGNAL;KSA812,PNP,150MW,SOT-23,TP,90-	
VQ31	0501-000341	TR-SMALL SIGNAL;KSC1623-L,NPN,200MW,SOT-23,TP,	
VQ32	0501-000314	TR-SMALL SIGNAL;KSA812,PNP,150MW,SOT-23,TP,90-	
VQ35	0501-000341	TR-SMALL SIGNAL;KSC1623-L,NPN,200MW,SOT-23,TP,	
VQ36	0501-000314	TR-SMALL SIGNAL;KSA812,PNP,150MW,SOT-23,TP,90-	
VQ37	0501-000314	TR-SMALL SIGNAL;KSA812,PNP,150MW,SOT-23,TP,90-	
VQ38	0501-000616	TR-SMALL SIGNAL;KSC2328A-Y,NPN,1W,TO-92L,TP,16	
VQ4	0501-000341	TR-SMALL SIGNAL;KSC1623-L,NPN,200MW,SOT-23,TP,	
VQ5	0501-000341	TR-SMALL SIGNAL;KSC1623-L,NPN,200MW,SOT-23,TP,	
VQ6	0501-000314	TR-SMALL SIGNAL;KSA812,PNP,150MW,SOT-23,TP,90-	
VQ7	0501-000341	TR-SMALL SIGNAL;KSC1623-L,NPN,200MW,SOT-23,TP,	
VQ8	0501-000341	TR-SMALL SIGNAL;KSC1623-L,NPN,200MW,SOT-23,TP,	
VQ9	0501-000341	TR-SMALL SIGNAL;KSC1623-L,NPN,200MW,SOT-23,TP,	
VR1	2007-000124	R-CHIP;2.2KOHM,5%,1/16W,DA,TP,1608	
VR10	2007-000124	R-CHIP;2.2KOHM,5%,1/16W,DA,TP,1608	
VR100	2007-000074	R-CHIP;100OHM,5%,1/16W,DA,TP,1608	
VR101	2007-001167	R-CHIP;75OHM,5%,1/16W,DA,TP,1608	
VR103	2007-001167	R-CHIP;75OHM,5%,1/16W,DA,TP,1608	
VR105	2007-001167	R-CHIP;75OHM,5%,1/16W,DA,TP,1608	
VR106	2007-000078	R-CHIP;1KOHM,5%,1/16W,DA,TP,1608	
VR109	2007-000078	R-CHIP;1KOHM,5%,1/16W,DA,TP,1608	
VR11	2007-000090	R-CHIP;10KOHM,5%,1/16W,DA,TP,1608	
VR110	2007-000078	R-CHIP;1KOHM,5%,1/16W,DA,TP,1608	
VR111	2007-000090	R-CHIP;10KOHM,5%,1/16W,DA,TP,1608	
VR112	2007-000107	R-CHIP;470KOHM,5%,1/16W,DA,TP,1608	
VR113	2007-000103	R-CHIP;120KOHM,5%,1/16W,DA,TP,1608	
VR114	2007-000090	R-CHIP;10KOHM,5%,1/16W,DA,TP,1608	
VR115	2007-000074	R-CHIP;100OHM,5%,1/16W,DA,TP,1608	
VR119	2007-000074	R-CHIP;100OHM,5%,1/16W,DA,TP,1608	
VR12	2007-000078	R-CHIP;1KOHM,5%,1/16W,DA,TP,1608	
VR120	2007-000074	R-CHIP;100OHM,5%,1/16W,DA,TP,1608	
VR121	2007-000074	R-CHIP;100OHM,5%,1/16W,DA,TP,1608	
VR122	2007-000074	R-CHIP;100OHM,5%,1/16W,DA,TP,1608	
VR123	2007-000074	R-CHIP;100OHM,5%,1/16W,DA,TP,1608	
VR124	2007-000074	R-CHIP;100OHM,5%,1/16W,DA,TP,1608	
VR125	2007-000074	R-CHIP;100OHM,5%,1/16W,DA,TP,1608	
VR126	2007-000074	R-CHIP;100OHM,5%,1/16W,DA,TP,1608	
VR127	2007-000084	R-CHIP;4.7KOHM,5%,1/16W,DA,TP,1608	
VR128	2007-000084	R-CHIP;4.7KOHM,5%,1/16W,DA,TP,1608	
VR129	2007-000074	R-CHIP;100OHM,5%,1/16W,DA,TP,1608	
VR13	2007-000572	R-CHIP;220OHM,5%,1/10W,DA,TP,2012	
VR14	2007-000078	R-CHIP;1KOHM,5%,1/16W,DA,TP,1608	
VR15	2007-000078	R-CHIP;1KOHM,5%,1/16W,DA,TP,1608	
VR16	2007-000078	R-CHIP;1KOHM,5%,1/16W,DA,TP,1608	
VR17	2007-000082	R-CHIP;3.3KOHM,5%,1/16W,DA,TP,1608	
VR18	2007-000070	R-CHIP;0OHM,5%,1/16W,DA,TP,1608	
VR19	2007-000074	R-CHIP;100OHM,5%,1/16W,DA,TP,1608	
VR2	2007-000121	R-CHIP;820OHM,5%,1/16W,DA,TP,1608	
VR20	2007-000822	R-CHIP;390OHM,5%,1/10W,DA,TP,2012	
VR200	2007-000822	R-CHIP;390OHM,5%,1/10W,DA,TP,2012	
VR201	2007-000575	R-CHIP;220OHM,5%,1/8W,DA,TP,3216	
VR204	2007-000113	R-CHIP;330OHM,5%,1/16W,DA,TP,1608	

Loc. No	Part No	Description and Specification	Remark
VR205	2007-000113	R-CHIP:33OHM,5%,1/16W,DA,TP,1608	
VR206	2007-000113	R-CHIP:33OHM,5%,1/16W,DA,TP,1608	
VR207	2007-000113	R-CHIP:33OHM,5%,1/16W,DA,TP,1608	
VR208	2007-000074	R-CHIP:100OHM,5%,1/16W,DA,TP,1608	
VR209	2007-000113	R-CHIP:33OHM,5%,1/16W,DA,TP,1608	
VR21	2007-000078	R-CHIP:1KOHM,5%,1/16W,DA,TP,1608	
VR210	2007-000084	R-CHIP:4.7KOHM,5%,1/16W,DA,TP,1608	
VR211	2007-000074	R-CHIP:100OHM,5%,1/16W,DA,TP,1608	
VR212	2007-000113	R-CHIP:33OHM,5%,1/16W,DA,TP,1608	
VR213	2007-000113	R-CHIP:33OHM,5%,1/16W,DA,TP,1608	
VR214	2007-000113	R-CHIP:33OHM,5%,1/16W,DA,TP,1608	
VR215	2007-000113	R-CHIP:33OHM,5%,1/16W,DA,TP,1608	
VR216	2007-000113	R-CHIP:33OHM,5%,1/16W,DA,TP,1608	
VR217	2007-000113	R-CHIP:33OHM,5%,1/16W,DA,TP,1608	
VR218	2007-000113	R-CHIP:33OHM,5%,1/16W,DA,TP,1608	
VR219	2007-000113	R-CHIP:33OHM,5%,1/16W,DA,TP,1608	
VR22	2007-000121	R-CHIP:820OHM,5%,1/16W,DA,TP,1608	
VR220	2007-000113	R-CHIP:33OHM,5%,1/16W,DA,TP,1608	
VR221	2007-000113	R-CHIP:33OHM,5%,1/16W,DA,TP,1608	
VR222	2007-000113	R-CHIP:33OHM,5%,1/16W,DA,TP,1608	
VR223	2007-000113	R-CHIP:33OHM,5%,1/16W,DA,TP,1608	
VR224	2007-000078	R-CHIP:1KOHM,5%,1/16W,DA,TP,1608	
VR225	2007-000124	R-CHIP:2.2KOHM,5%,1/16W,DA,TP,1608	
VR23	2007-000074	R-CHIP:100OHM,5%,1/16W,DA,TP,1608	
VR24	2007-001657	R-CHIP:240OHM,1%,1/10W,DA,TP,2012	
VR25	2007-000539	R-CHIP:200OHM,5%,1/16W,DA,TP,1608	
VR27	2007-000077	R-CHIP:470OHM,5%,1/16W,DA,TP,1608	
VR28	2007-000572	R-CHIP:220OHM,5%,1/10W,DA,TP,2012	
VR29	2007-000074	R-CHIP:100OHM,5%,1/16W,DA,TP,1608	
VR3	2007-000078	R-CHIP:1KOHM,5%,1/16W,DA,TP,1608	
VR30	2007-001167	R-CHIP:75OHM,5%,1/16W,DA,TP,1608	
VR31	2007-000090	R-CHIP:10KOHM,5%,1/16W,DA,TP,1608	
VR32	2007-000078	R-CHIP:1KOHM,5%,1/16W,DA,TP,1608	
VR33	2007-000078	R-CHIP:1KOHM,5%,1/16W,DA,TP,1608	
VR34	2007-000077	R-CHIP:470OHM,5%,1/16W,DA,TP,1608	
VR35	2007-000822	R-CHIP:390OHM,5%,1/10W,DA,TP,2012	
VR36	2007-000078	R-CHIP:1KOHM,5%,1/16W,DA,TP,1608	
VR37	2007-000082	R-CHIP:3.3KOHM,5%,1/16W,DA,TP,1608	
VR38	2007-000070	R-CHIP:0OHM,5%,1/16W,DA,TP,1608	
VR39	2007-000074	R-CHIP:100OHM,5%,1/16W,DA,TP,1608	
VR4	2007-000074	R-CHIP:100OHM,5%,1/16W,DA,TP,1608	
VR40	2007-000121	R-CHIP:820OHM,5%,1/16W,DA,TP,1608	
VR41	2007-000122	R-CHIP:1.2KOHM,5%,1/16W,DA,TP,1608	
VR42	2007-000122	R-CHIP:1.2KOHM,5%,1/16W,DA,TP,1608	
VR43	2007-001657	R-CHIP:240OHM,1%,1/10W,DA,TP,2012	
VR44	2007-000539	R-CHIP:200OHM,5%,1/16W,DA,TP,1608	
VR46	2007-000572	R-CHIP:220OHM,5%,1/10W,DA,TP,2012	
VR47	2007-000074	R-CHIP:100OHM,5%,1/16W,DA,TP,1608	
VR48	2007-000090	R-CHIP:10KOHM,5%,1/16W,DA,TP,1608	
VR49	2007-000078	R-CHIP:1KOHM,5%,1/16W,DA,TP,1608	
VR5	2007-000074	R-CHIP:100OHM,5%,1/16W,DA,TP,1608	
VR50	2007-000822	R-CHIP:390OHM,5%,1/10W,DA,TP,2012	
VR51	2007-000078	R-CHIP:1KOHM,5%,1/16W,DA,TP,1608	
VR52	2007-000120	R-CHIP:680OHM,5%,1/16W,DA,TP,1608	
VR53	2007-000082	R-CHIP:3.3KOHM,5%,1/16W,DA,TP,1608	

Loc. No	Part No	Description and Specification	Remark
VR54	2007-000070	R-CHIP:0OHM,5%,1/16W,DA,TP,1608	
VR55	2007-000074	R-CHIP:100OHM,5%,1/16W,DA,TP,1608	
VR56	2007-001657	R-CHIP:240OHM,1%,1/10W,DA,TP,2012	
VR57	2007-000539	R-CHIP:200OHM,5%,1/16W,DA,TP,1608	
VR59	2007-000121	R-CHIP:820OHM,5%,1/16W,DA,TP,1608	
VR6	2007-001167	R-CHIP:75OHM,5%,1/16W,DA,TP,1608	
VR60	2007-000074	R-CHIP:100OHM,5%,1/16W,DA,TP,1608	
VR61	2007-000572	R-CHIP:220OHM,5%,1/10W,DA,TP,2012	
VR62	2007-000074	R-CHIP:100OHM,5%,1/16W,DA,TP,1608	
VR63	2007-001167	R-CHIP:75OHM,5%,1/16W,DA,TP,1608	
VR64	2007-000078	R-CHIP:1KOHM,5%,1/16W,DA,TP,1608	
VR65	2007-000078	R-CHIP:1KOHM,5%,1/16W,DA,TP,1608	
VR66	2007-000078	R-CHIP:1KOHM,5%,1/16W,DA,TP,1608	
VR67	2007-000079	R-CHIP:1.8KOHM,5%,1/16W,DA,TP,1608	
VR68	2007-000076	R-CHIP:330OHM,5%,1/16W,DA,TP,1608	
VR69	2007-000070	R-CHIP:0OHM,5%,1/16W,DA,TP,1608	
VR7	2007-001657	R-CHIP:240OHM,1%,1/10W,DA,TP,2012	
VR70	2007-000090	R-CHIP:10KOHM,5%,1/16W,DA,TP,1608	
VR72	2007-000965	R-CHIP:5.1KOHM,5%,1/16W,DA,TP,1608	
VR74	2007-000076	R-CHIP:330OHM,5%,1/16W,DA,TP,1608	
VR75	2007-000096	R-CHIP:30KOHM,5%,1/16W,DA,TP,1608	
VR76	2007-000120	R-CHIP:680OHM,5%,1/16W,DA,TP,1608	
VR77	2007-000079	R-CHIP:1.8KOHM,5%,1/16W,DA,TP,1608	
VR78	2007-001010	R-CHIP:51KOHM,5%,1/16W,DA,TP,1608	
VR8	2007-000074	R-CHIP:100OHM,5%,1/16W,DA,TP,1608	
VR80	2007-000074	R-CHIP:100OHM,5%,1/16W,DA,TP,1608	
VR81	2007-000539	R-CHIP:200OHM,5%,1/16W,DA,TP,1608	
VR83	2007-000090	R-CHIP:10KOHM,5%,1/16W,DA,TP,1608	
VR84	2007-000074	R-CHIP:100OHM,5%,1/16W,DA,TP,1608	
VR85	2007-000074	R-CHIP:100OHM,5%,1/16W,DA,TP,1608	
VR86	2007-001167	R-CHIP:75OHM,5%,1/16W,DA,TP,1608	
VR87	2007-000120	R-CHIP:680OHM,5%,1/16W,DA,TP,1608	
VR88	2007-000078	R-CHIP:1KOHM,5%,1/16W,DA,TP,1608	
VR9	2007-000539	R-CHIP:200OHM,5%,1/16W,DA,TP,1608	
VR90	2007-000509	R-CHIP:2.4KOHM,1%,1/16W,DA,TP,1608	
VR91	2007-001442	R-CHIP:10OHM,5%,1/16W,DA,TP,1608	
VR92	2007-000078	R-CHIP:1KOHM,5%,1/16W,DA,TP,1608	
VR93	2007-000078	R-CHIP:1KOHM,5%,1/16W,DA,TP,1608	
VR94	2007-000120	R-CHIP:680OHM,5%,1/16W,DA,TP,1608	
VR95	2007-000074	R-CHIP:100OHM,5%,1/16W,DA,TP,1608	
VR96	2007-000570	R-CHIP:220OHM,1%,1/16W,DA,TP,1608	
VR97	2007-000570	R-CHIP:220OHM,1%,1/16W,DA,TP,1608	
VR98	2007-000570	R-CHIP:220OHM,1%,1/16W,DA,TP,1608	
VR99	2007-000570	R-CHIP:220OHM,1%,1/16W,DA,TP,1608	
VY1	2801-003366	CRYSTAL-UNIT;30MHZ,50PPM,28-AAM,20PF,60OHM,	
VZD1	B4106-0230	DIODE-ZENER,CHIP;UDZ3.9B-TE17 3.89/4.16V 5MA T	
<b>29</b>	<b>AH90-10727U</b>	<b>ASSY- PCB FRONT;DVD858V,CHN</b>	
FC1	2401-000907	C-AL:22UF,20%,16V,GP,-.5X11,2MM	
FC10	2202-000780	C-CERAMIC,MLC-AXIAL;100NF,+80-20%,50V,Y5V,TP,3.5	
FC12	2401-001895	C-AL:100UF,20%,16V,GP,BK,6.3X11MM,2	
FC13	2202-000780	C-CERAMIC,MLC-AXIAL;100NF,+80-20%,50V,Y5V,TP,3.5	
FC14	2202-000780	C-CERAMIC,MLC-AXIAL;100NF,+80-20%,50V,Y5V,TP,3.5	
FC15	2401-001895	C-AL:100UF,20%,16V,GP,BK,6.3X11MM,2	

Loc. No	Part No	Description and Specification	Remark
FC2	2202-000161	C-CERAMIC,MLC-AXIAL;15PF,5%,50V,NPO,TP,2.5X4.3,-	
FC3	2202-000161	C-CERAMIC,MLC-AXIAL;15PF,5%,50V,NPO,TP,2.5X4.3,-	
FC4	2202-000780	C-CERAMIC,MLC-AXIAL;100NF,+80-20%,50V,Y5V,TP,3.5	
FC5	2401-001511	C-AL;47UF,20%,16V,GP,-,6X7,5	
FC6	2202-000780	C-CERAMIC,MLC-AXIAL;100NF,+80-20%,50V,Y5V,TP,3.5	
FC7	2202-000780	C-CERAMIC,MLC-AXIAL;100NF,+80-20%,50V,Y5V,TP,3.5	
FC8	2401-001511	C-AL;47UF,20%,16V,GP,-,6X7,5	
FC9	2401-001572	C-AL;47UF,20%,50V,GP,-,6.3X11,2.5MM	
FD10	0401-000101	DIODE-SWITCHING;1N4148,100V,200MA,500MW,4NS,DO	
FD5	0601-000218	LED;INVERTER,RED,3MM,650NM	
FD6	0401-000101	DIODE-SWITCHING;1N4148,100V,200MA,500MW,4NS,DO	
FD7	0401-000101	DIODE-SWITCHING;1N4148,100V,200MA,500MW,4NS,DO	
FD8	0401-000101	DIODE-SWITCHING;1N4148,100V,200MA,500MW,4NS,DO	
FD9	0403-000551	DIODE-ZENER;MTZ3.9B,3.9V,3.89-4.16V,500MW,	
FIC1	AH11-10002F	IC-MASK ROM;LC86P6232,-,DIP	
FIC2	1203-001252	IC-VOL. DETECTOR;7545,TO-92,3P,-,PLASTIC,-,200M	
FIC3	AH07-20045K	VF-DISPLAY;SVA-11MM08,14SEG,26X107.5MM,DV	
FIC4	AH59-60001B	REMOCON-MODULE;RC-38S2S 12MM,CD22R MESH,-,-,-	
FJP1	3708-001083	CONNECTOR-FPC/FC/PIC;28P,1.25MM,ANGLE,SN	
FL1	2701-000114	INDUCTOR-AXIAL;10UH,10%,2.5X3.4MM	
FLT-CU	AH69-22001A	CUSHION-FLT;-EVA SPONGE,50,12,T2,60,DVD-8	
FR10	2001-000281	R-CARBON;100OHM,5%,1/8W,AA,TP,1.8X3.2MM	
FR11	2001-000281	R-CARBON;100OHM,5%,1/8W,AA,TP,1.8X3.2MM	
FR12	2001-000281	R-CARBON;100OHM,5%,1/8W,AA,TP,1.8X3.2MM	
FR13	2001-000281	R-CARBON;100OHM,5%,1/8W,AA,TP,1.8X3.2MM	
FR14	Do not order	WIRE-NO SHEATH CU;SPCW,300V,52.4MM,1/0.5MM,-,-	S.N.A
FR15	Do not order	WIRE-NO SHEATH CU;SPCW,300V,52.4MM,1/0.5MM,-,-	S.N.A
FR16	2001-000027	R-CARBON;100OHM,5%,1/4W,AA,TP,2.4X6.4MM	
FR17	2001-000027	R-CARBON;100OHM,5%,1/4W,AA,TP,2.4X6.4MM	
FR18	2001-000449	R-CARBON;2.2KOHM,5%,1/8W,AA,TP,1.8X3.2M	
FR19	2001-000449	R-CARBON;2.2KOHM,5%,1/8W,AA,TP,1.8X3.2M	
FR20	2001-000449	R-CARBON;2.2KOHM,5%,1/8W,AA,TP,1.8X3.2M	
FR21	2001-000435	R-CARBON;1MOHM,5%,1/8W,AA,TP,1.8X3.2MM	
FR23	2001-000281	R-CARBON;100OHM,5%,1/8W,AA,TP,1.8X3.2MM	
FR24	2001-000281	R-CARBON;100OHM,5%,1/8W,AA,TP,1.8X3.2MM	
FR25	2001-000780	R-CARBON;470OHM,5%,1/8W,AA,TP,1.8X3.2MM	
FR26	2001-000281	R-CARBON;100OHM,5%,1/8W,AA,TP,1.8X3.2MM	
FR27	2001-000591	R-CARBON;3.3KOHM,5%,1/8W,AA,TP,1.8X3.2M	
FR28	2001-000591	R-CARBON;3.3KOHM,5%,1/8W,AA,TP,1.8X3.2M	
FR29	2001-000591	R-CARBON;3.3KOHM,5%,1/8W,AA,TP,1.8X3.2M	
FR30	2001-000429	R-CARBON;1KOHM,5%,1/8W,AA,TP,1.8X3.2MM	
FR31	2001-000429	R-CARBON;1KOHM,5%,1/8W,AA,TP,1.8X3.2MM	
FR32	2001-000429	R-CARBON;1KOHM,5%,1/8W,AA,TP,1.8X3.2MM	
FR33	2001-000429	R-CARBON;1KOHM,5%,1/8W,AA,TP,1.8X3.2MM	
FR34	2001-000429	R-CARBON;1KOHM,5%,1/8W,AA,TP,1.8X3.2MM	
FR43	2001-000793	R-CARBON;470OHM,5%,1/8W,AA,TP,1.8X3.2MM	
FR44	2001-000429	R-CARBON;1KOHM,5%,1/8W,AA,TP,1.8X3.2MM	
FR45	2001-000429	R-CARBON;1KOHM,5%,1/8W,AA,TP,1.8X3.2MM	
FR5	2001-000515	R-CARBON;220OHM,5%,1/8W,AA,TP,1.8X3.2MM	
FR6	2001-000281	R-CARBON;100OHM,5%,1/8W,AA,TP,1.8X3.2MM	
FR7	2001-000281	R-CARBON;100OHM,5%,1/8W,AA,TP,1.8X3.2MM	
FR8	2001-000281	R-CARBON;100OHM,5%,1/8W,AA,TP,1.8X3.2MM	
FR9	2001-000780	R-CARBON;470OHM,5%,1/8W,AA,TP,1.8X3.2MM	
FSW1	3404-001008	SWITCH-TACT;12V,20MA,160+-50,6X7.9X3.5MM,D	
FSW2	3404-001008	SWITCH-TACT;12V,20MA,160+-50,6X7.9X3.5MM,D	

Loc. No	Part No	Description and Specification	Remark
FSW3	3404-001008	SWITCH-TACT;12V,20MA,160+-50,6X7.9X3.5MM,D	
FSW4	3404-001008	SWITCH-TACT;12V,20MA,160+-50,6X7.9X3.5MM,D	
FSW5	3404-001008	SWITCH-TACT;12V,20MA,160+-50,6X7.9X3.5MM,D	
FSW6	3404-001008	SWITCH-TACT;12V,20MA,160+-50,6X7.9X3.5MM,D	
FSW7	3404-001008	SWITCH-TACT;12V,20MA,160+-50,6X7.9X3.5MM,D	
FY1	2802-000108	RESONATOR-CERAMIC;12MHZ,0.5%,BK,10.0X5.0X10.0MM	
HOLDER	1EDA1-008-212	HOLDER FLT ABS BLK;CD-800	
<b>REM</b>	<b>AH59-10087F</b>	<b>REMOCON-ASSY;-,-,-,48,DVD905/SEA,S.S</b>	
	AH09-10062J	IC-MCH ; KS56C401-72, DVD705/S,32P,SOP,-	
	0501-000592	TR-SMALL SIGNAL;2SD1781K-QR,NPN,200MW,SOT-23,T	
	B1283-0028	RESONATOR-CERAMIC;910KHZ CSB910JB BEND J	
	AH64-50327A	DOOR-BATTERY;-;ABS94,HB,T2,L71 W60 H18,D/GR	



## MEMO

## 8. Block Diagram

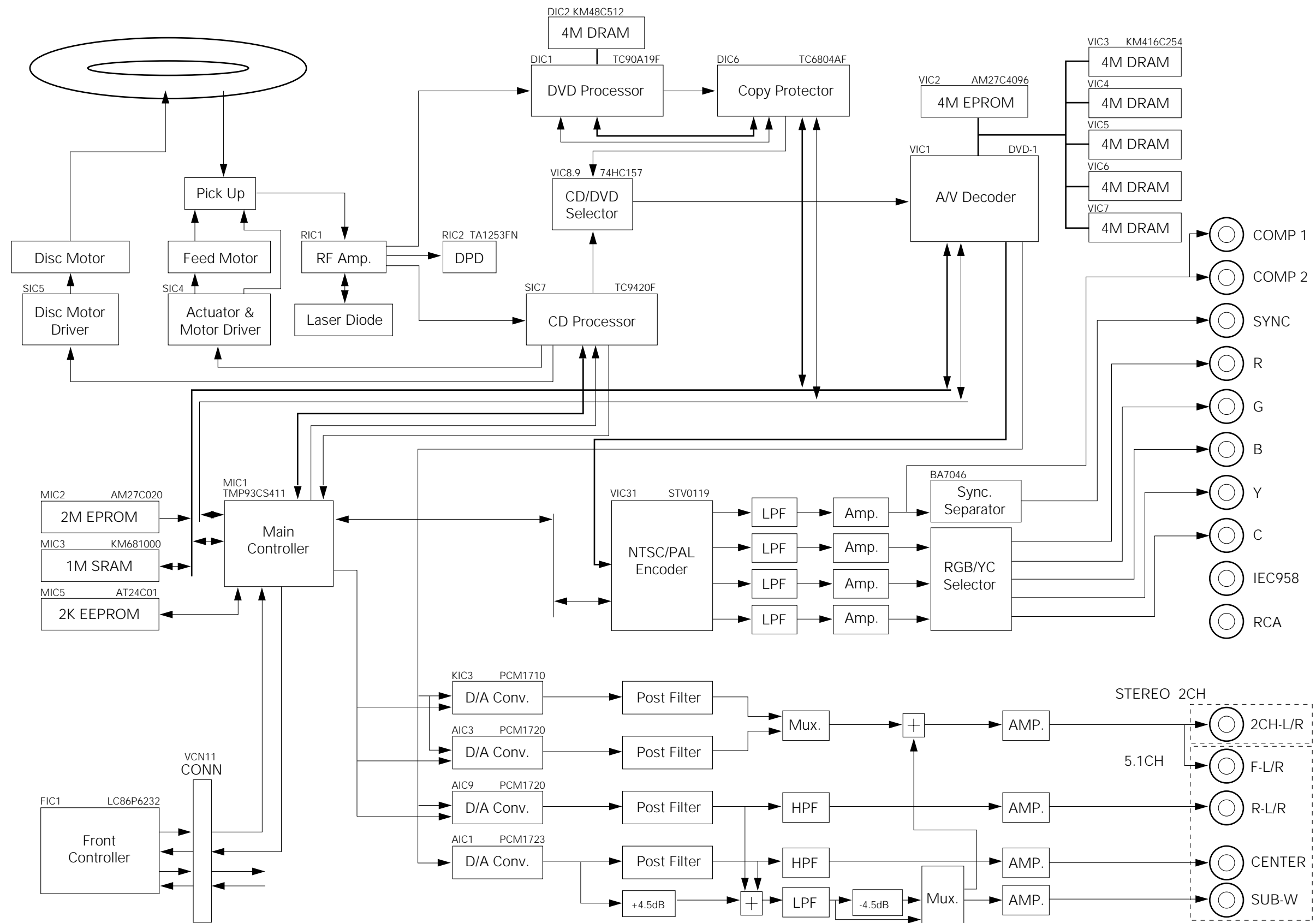

## MEMO

# 10. Wiring Diagram

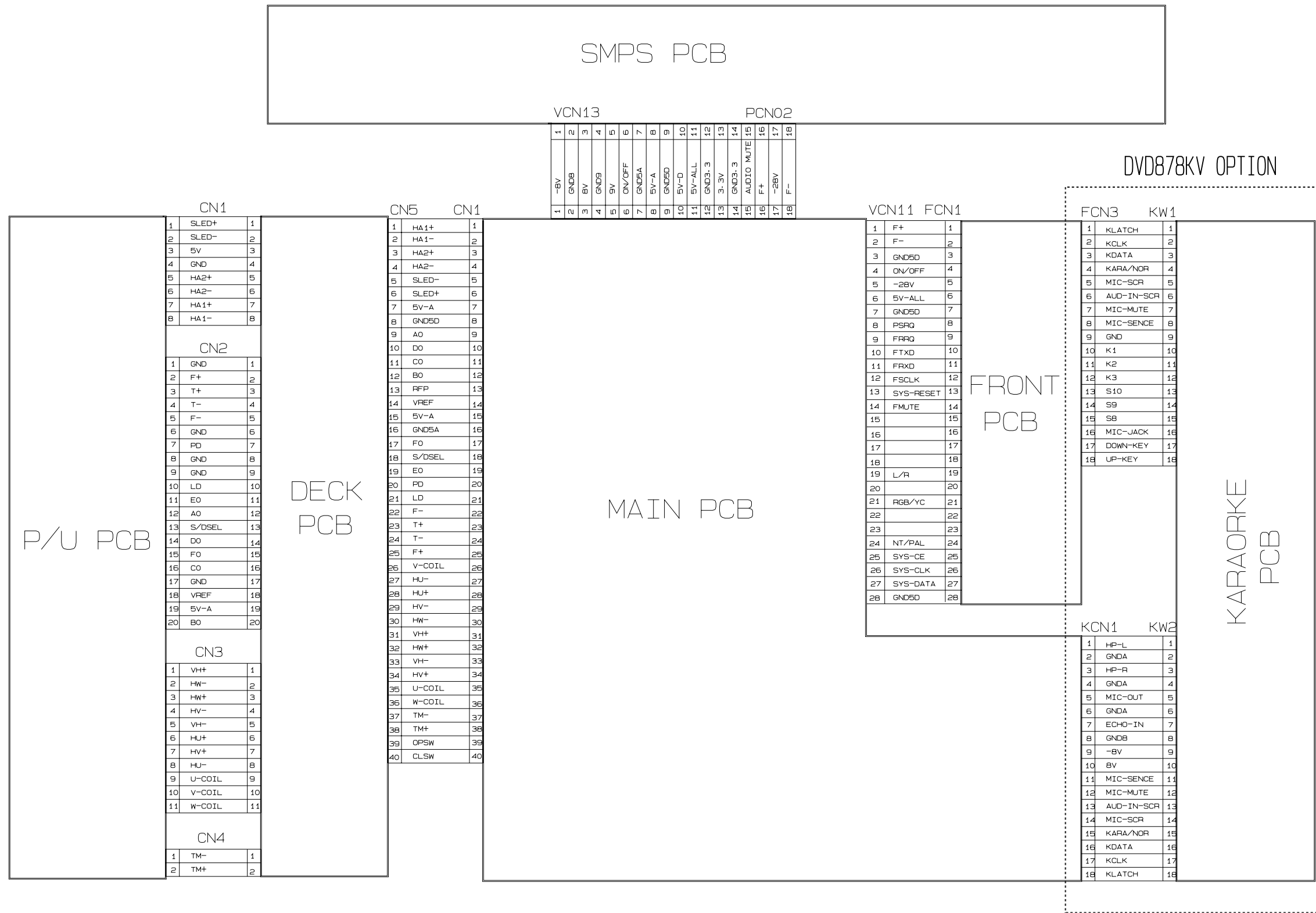

## MEMO

---

## 11. Schematic Diagrams

---

	Page
11-1 SMPS .....	11-2
11-2 FRONT .....	11-3
11-3 MICOM .....	11-4
11-4 SERVO .....	11-5
11-5 VIDEO .....	11-6
11-6 AUDIO-1 .....	11-7
11-7 AUDIO-2 .....	11-8
11-8 DATA PROCESSOR .....	11-9
11-9 A/V DECODER .....	11-10
11-10 PICK-UP/DECK .....	11-11

# 11-1 SMPS

NOTE : IF YOU CHECK THE VOLTAGE FOR PARTS IN HOT CIRCUIT, YOU MUST USE **PRIMARY GND** AS A COMMON TERMINAL.

**IMPORTANT SAFETY NOTICE**  
COMPONENT IDENTIFIED WITH THE MARK HAVE THE SPECIAL CHARACTERISTICS FOR SAFETY WHEN REPLACING ANY OF THESE COMPONENT. USE ONLY THE SAME TYPE.

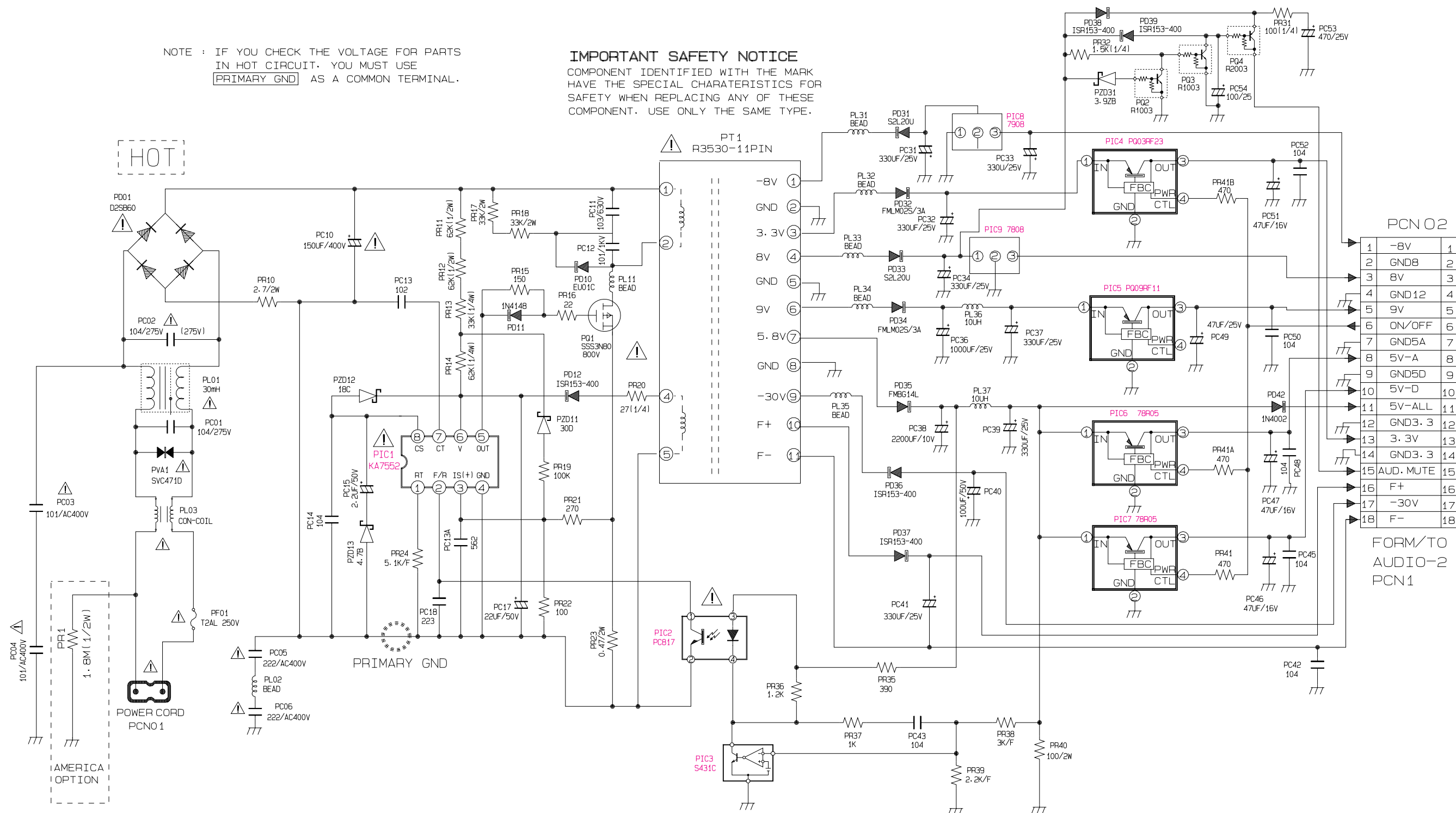

11-2 FRONT

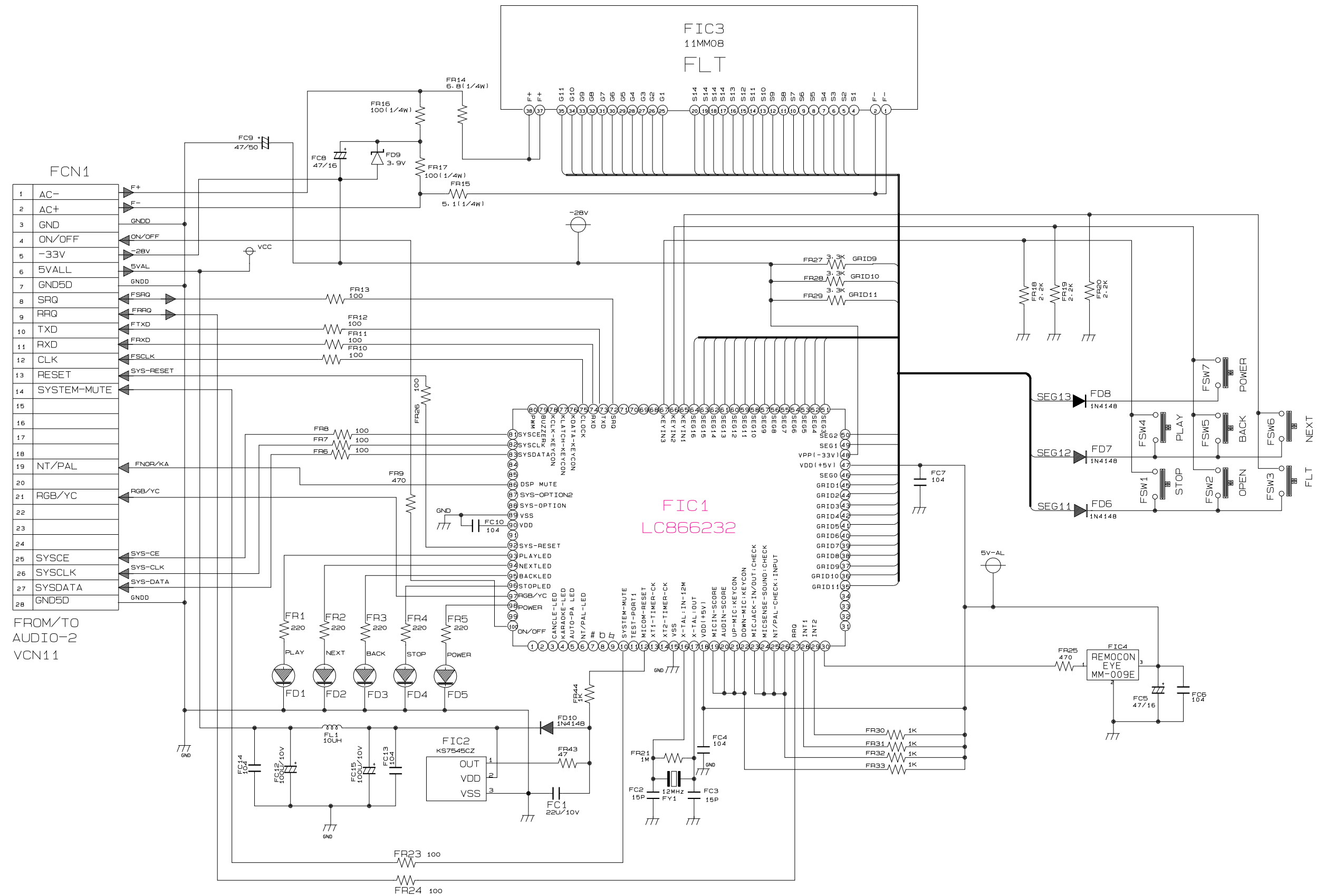



### 11-3 MICOM

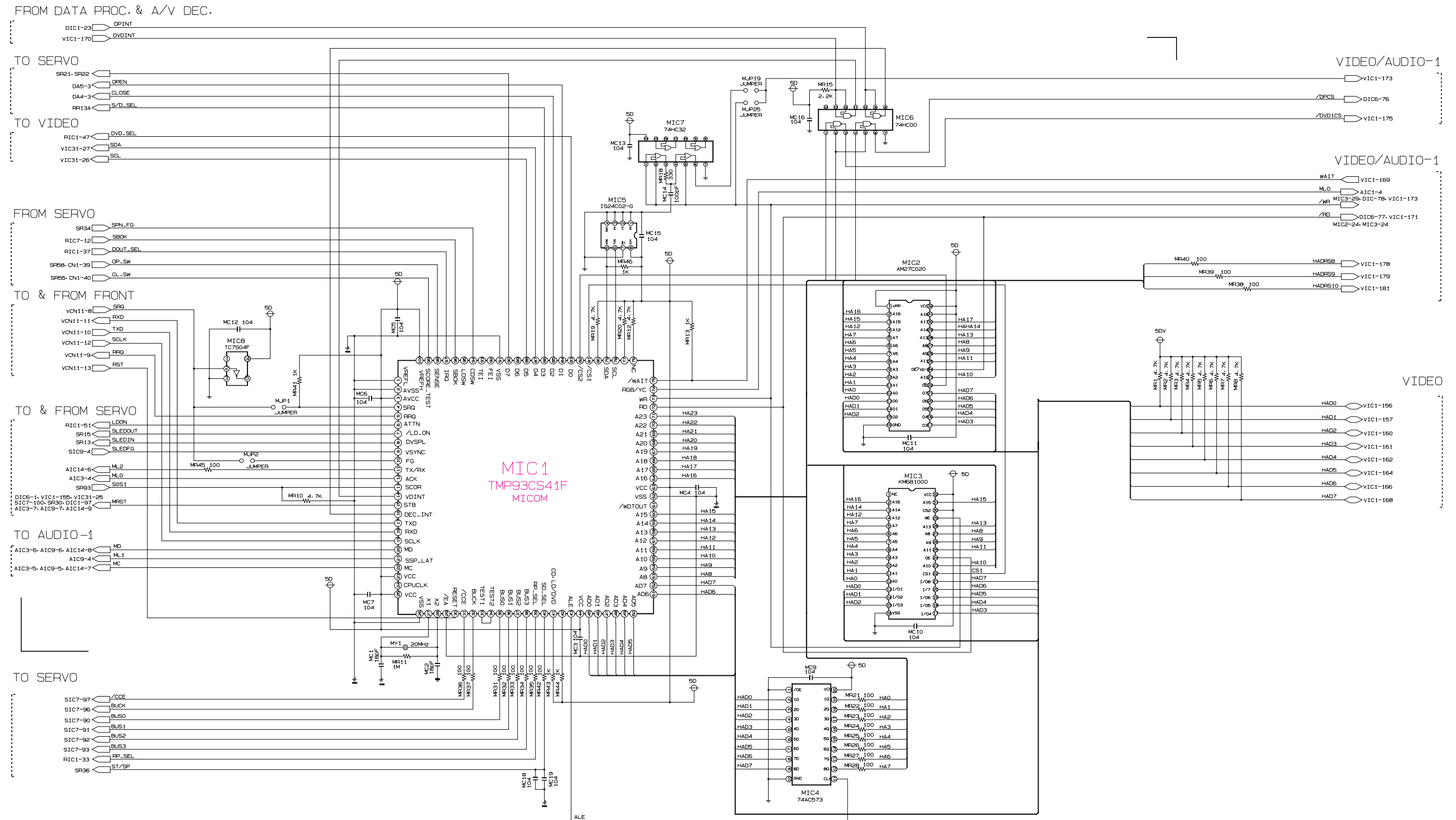

# 11-4 SERVO

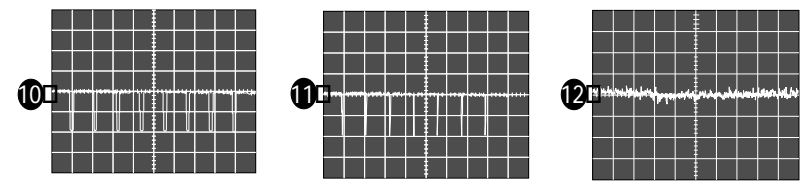
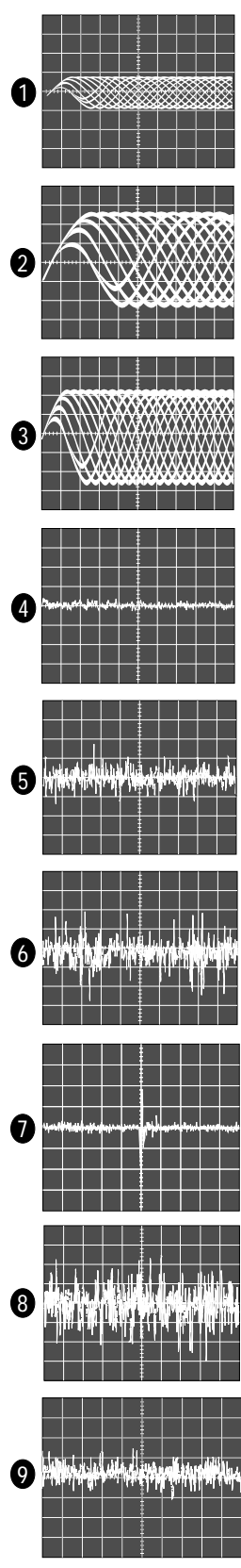
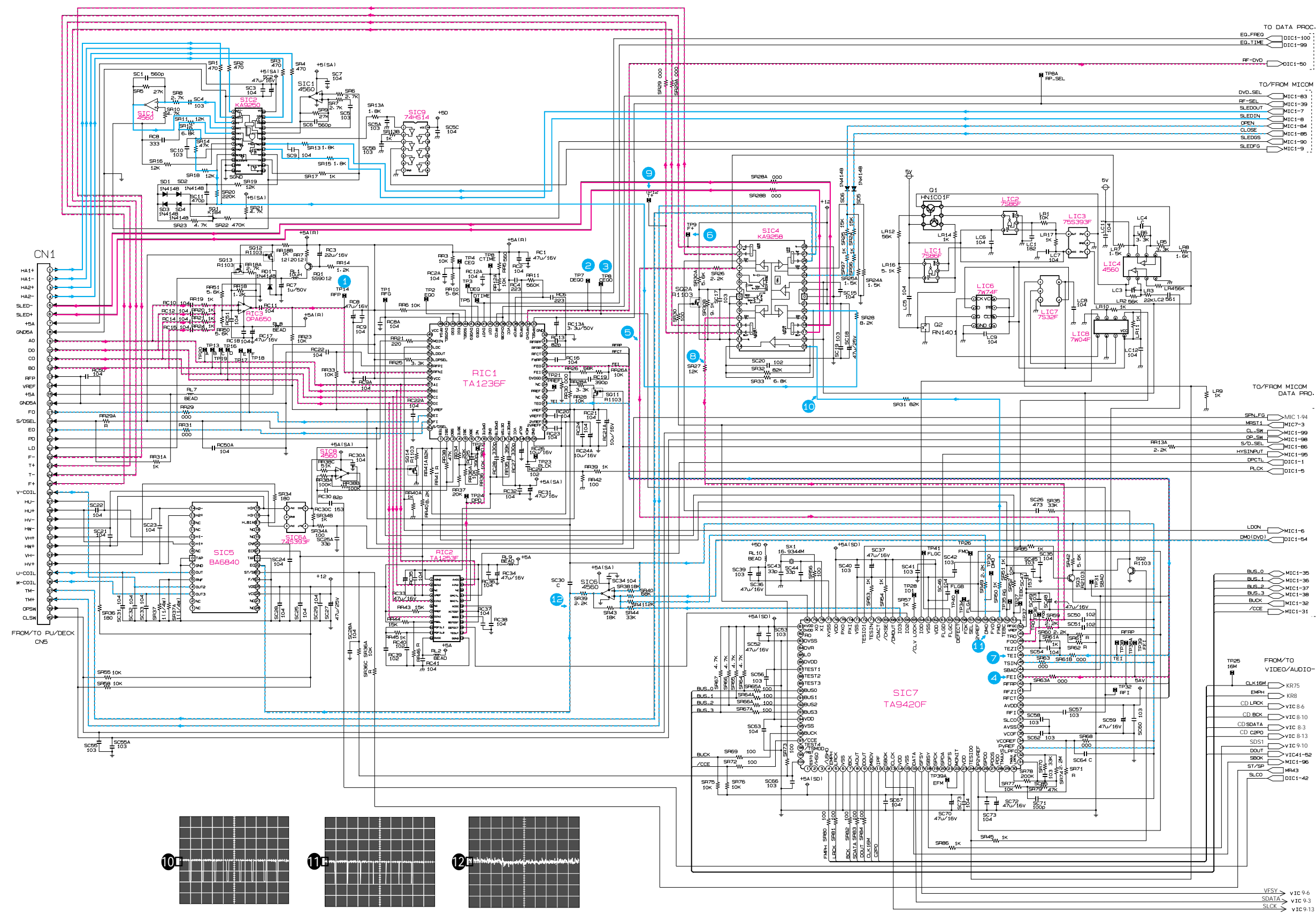





# 11-7 AUDIO - 2

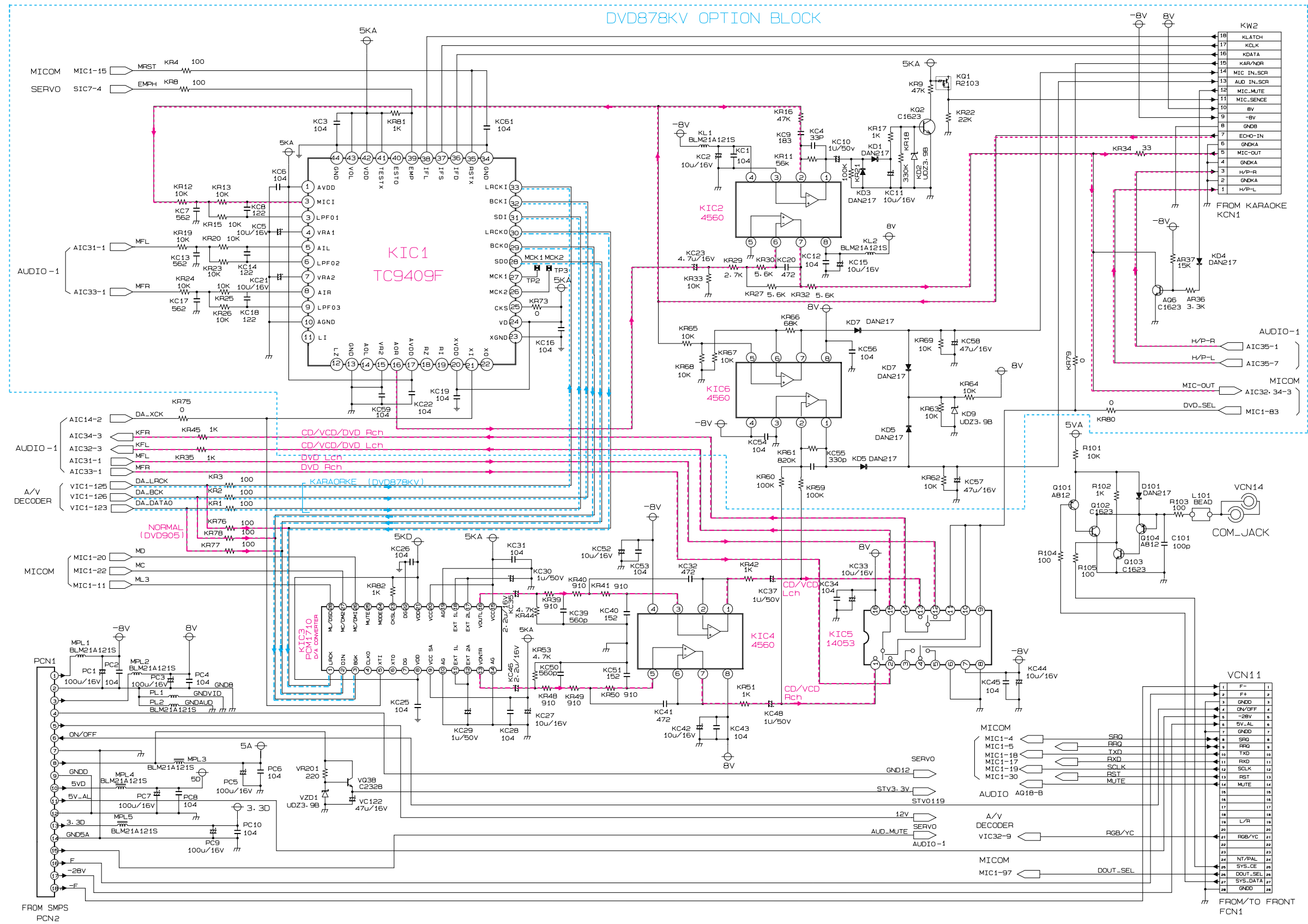

# 11-8 DATA PROCESSOR

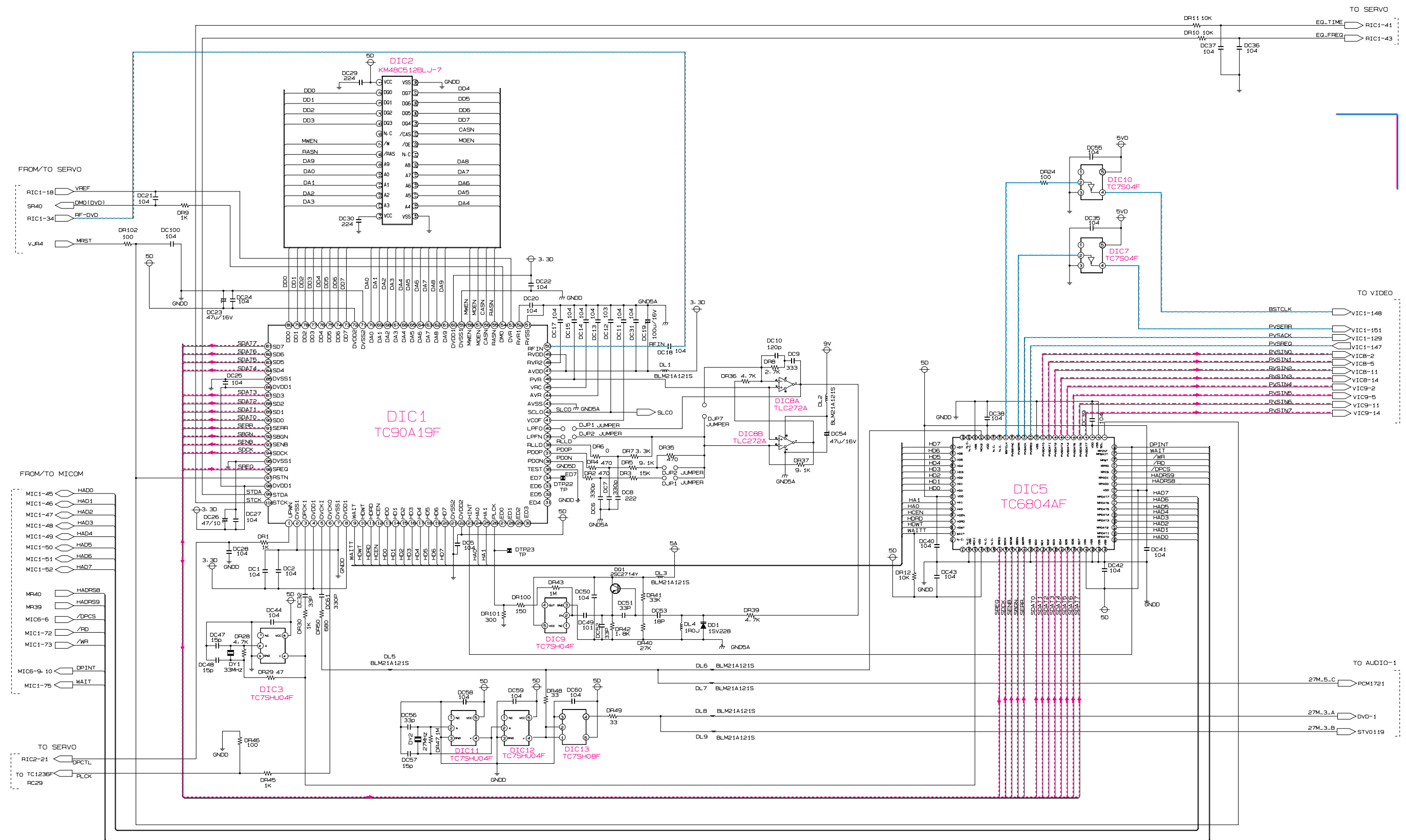

# 11-9 A/V DECORDER

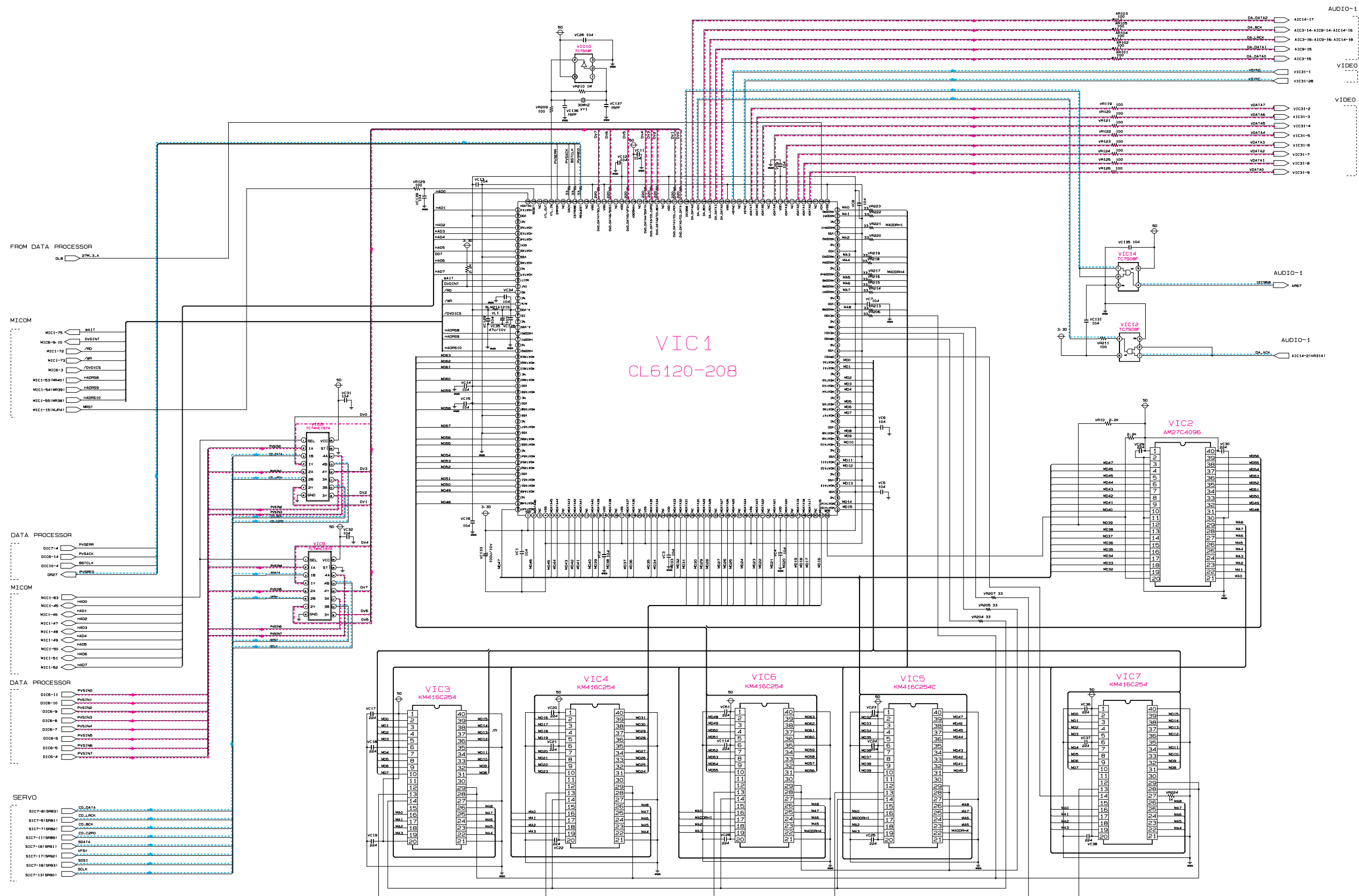

11-10 PICK-UP/DECK

